

DriftClip® DSL

Exterior Head of Wall

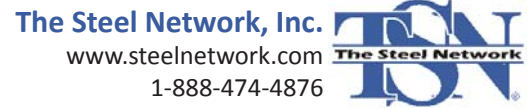

Material Composition

ASTM A1003/A1003M Structural Grade 50 (340) Type H, ST50H (ST340H): 50ksi (340MPa) minimum yield strength, 65ksi (450MPa) minimum tensile strength, 97mil minimum thickness (12 gauge, 0.1017" design thickness) with ASTM A653/A653M G90 (Z275) hot dipped galvanized coating.

The attachment of DriftClip DSL to the primary structure may be made with PAFs, screws, or bolt anchors depending on the base material (steel or concrete) and the design configuration. The step bushings used for attachment to structure are designed for use with ¼" maximum diameter fasteners. Designing this connection is the responsibility of the Structural Engineer of Record, and a minimum of two fasteners must be used.

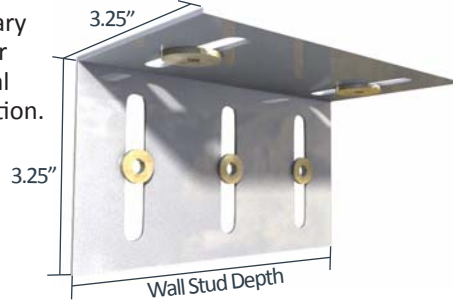

US Patent #6,612,087

DriftClip DSL Allowable (Unfactored) Loads¹

DriftClip® DSL, Recommended Allowable Load (lbs): F2												
Stud		Fastener Pattern 1					Fastener Pattern 2					
Thickness Mils (ga)	Yield Strength (ksi)	DSL362 w/2 #12 Screws	DSL600 w/2 #12 Screws	DSL600 w/3 #12 Screws	DSL800 w/2 #12 Screws	DSL800 w/3 #12 Screws	DSL362 w/2 #12 Screws	DSL600 w/2 #12 Screws	DSL600 w/3 #12 Screws	DSL800 w/2 #12 Screws	DSL800 w/3 #12 Screws	
33 (20)	33	357	377	565	377	565	129	377	418	377	565	
33 (20)	50	357	544	776	544	817	129	418	418	544	817	
43 (18)	33	357	561	776	561	841	129	418	418	560	841	
43 (18)	50	357	776	776	810	1,041	129	418	418	810	1,041	
54 (16)	33	357	776	776	789	1,041	129	418	418	789	1,041	
54 (16)	50	357	776	776	1,041	1,041	129	418	418	1,041	1,041	
68 (14)	50	357	776	776	1,041	1,041	129	418	418	1,041	1,041	
97 (12)	50	357	776	776	1,041	1,041	129	418	418	1,041	1,041	
Max Allowable Clip Load		357	776	1,041	1,041	1,041	129	418	418	1,041	1,041	

Notes:

- Design loads are for attachment of DriftClip DSL to stud only. Load tables reflect horizontal loads (F2).
- Attachment to structure engineered by others.
- Allowable loads have not been increased for wind, seismic, or other factors.
- Two (2) #12 screws are provided with each DriftClip DSL for attachment to stud.
- DriftClip DSL allows up to 2" of vertical deflection (1" up and 1" down), and 2" lateral drift (1" left and 1" right in plane). Deflection requirements greater than 2" lateral drift are available.
- One row of bridging is recommended at a maximum distance of 18" from DriftClip to resist torsional effects.
- Attachment to structure engineered by others. As a design reference, follow ICC-ESR-3332 for allowable loads for screw fasteners of ¼" - 20 size with various plate thickness.

¹ For LRFD Design Strengths refer to ICC-ESR-2049.

Nomenclature

DriftClip DSL is classified by multiplying stud depth by 100.*

Example: 6" stud depth

Designate: DriftClip® DSL600

* Parts with the designation "-CA" on the end of the part name includes a special bushing available to allow connection to the side of the concrete slab using two ¼" concrete screw anchors

** If more than 2" lateral drift is required, contact TSN engineering.

*** Three screws & step bushings are available in 6" sizes and higher. Specify that 3 slots are needed when placing order.

Load Direction



Fastener Patterns

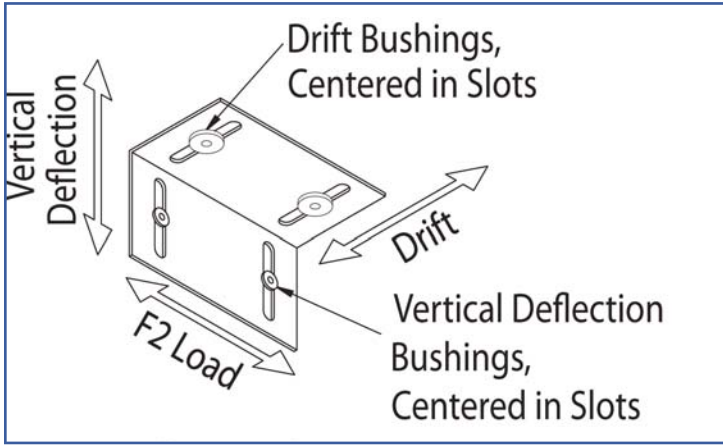

Fastener Pattern 1 replicates a condition of out-of-plane wind or seismic force with no vertical live load deflection or in-plane drift.

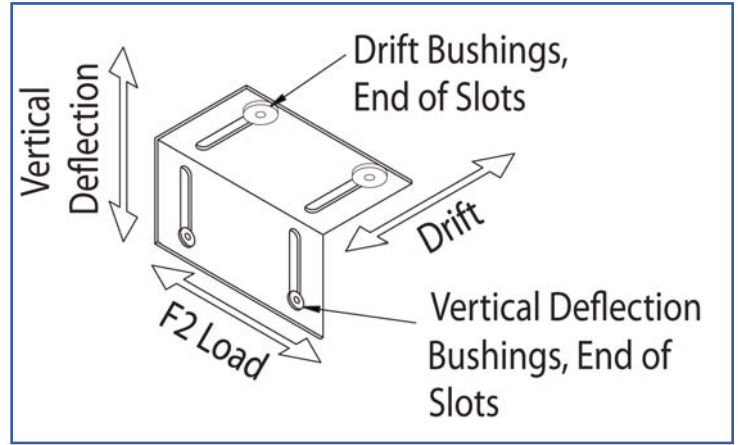

Fastener Pattern 2 replicates a condition of out-of-plane wind or seismic force with full vertical live load deflection and full in-plane drift.



DriftClip DSL362/400,
DSL600 & DSL800
ICC-ESR-2049
www.icc-es.org

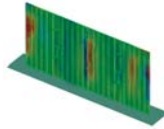

DriftClip DSL Series
Blast and Seismic Design data
www.steelnetwork.com

** For more information or to review a copy of each of these reports, please visit our website at <http://www.steelnetwork.com/Site/TechnicalData>