

DriftClip® DSLD Installation Instructions

Vertical Deflection & Drift @ Head of Wall

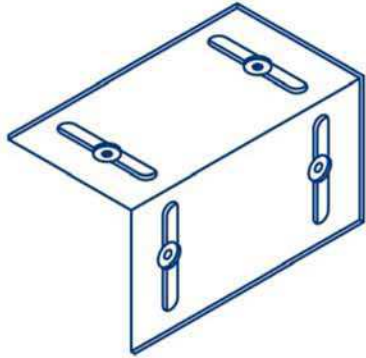

DriftClip® DSLD



Standard Step Bushing
(Do not remove unless otherwise directed)

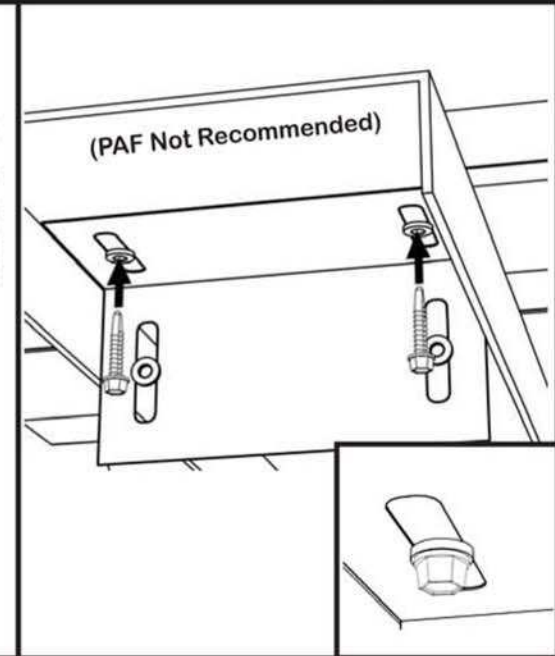
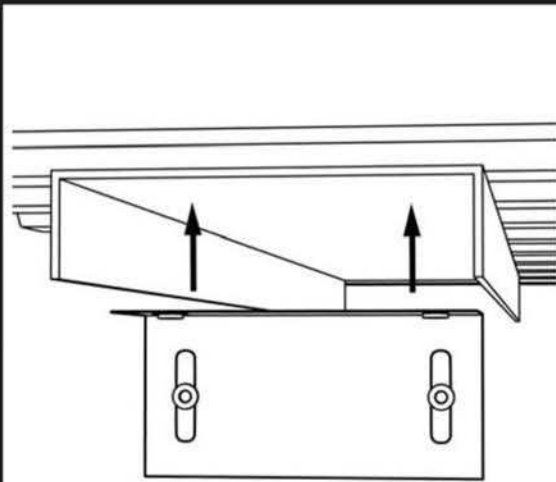
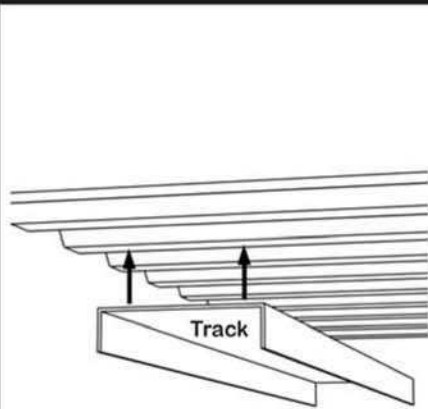

Deflection Gap

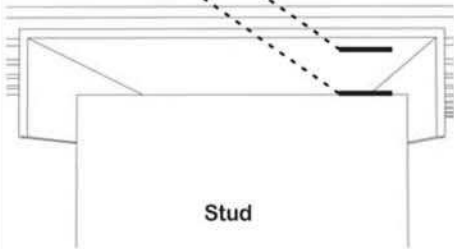

Install screws using a screw gun that does not exceed 2,500 rpm.

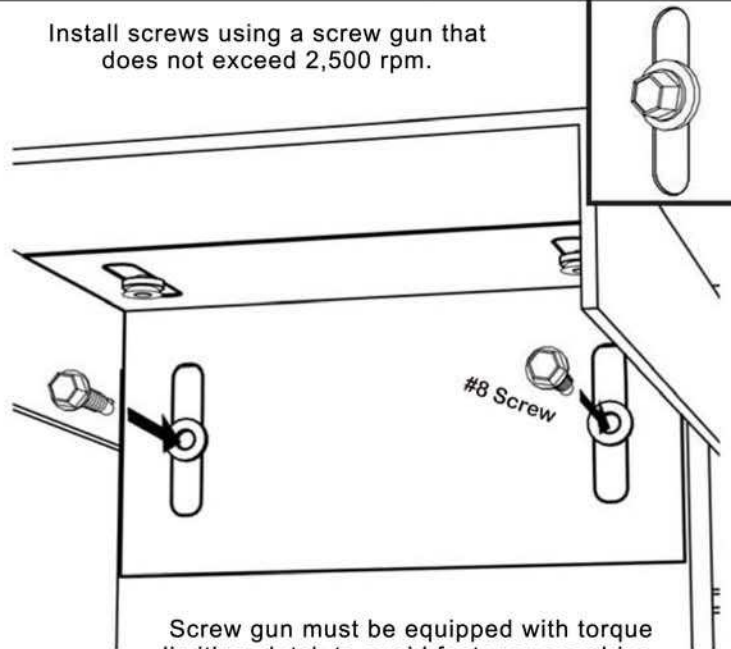

Screw gun must be equipped with torque limiting clutch to avoid fastener overdrive.

For Installation, Technical, or Submittal questions, contact TSN at (888) 474-4876.

Email us at tsn@steelnetwork.com.

Visit www.steelnetwork.com and discover the value of each TSN Solution.