

DriftTrak® Headed Stud - PTS

Slab Integrated Bypass - Post Tensioned Concrete Slabs



Description

DriftTrak® Headed Stud - PTS saves the time and expense of installing DriftTrak after the Post-Tensioned Concrete Slab (PTS) has been poured, by integrating it directly into the slab before pouring. The headed studs come preinstalled to the DriftTrak and function as the attachment to the post-tensioned slab instead of welding to the pour stop angle and use of PAF's or anchors. The DriftTrak is sized to fit above or under the high-strength tendon reinforcing at edge of slab. Once concrete is poured, the DriftTrak is ready to support exterior steel framing using any DriftTrak Bypass clip (DTSLB-PTS or DTLB-PTS) to accommodate vertical deflection and lateral drift requirements or provide a rigid attachment to the floor slab.



US Patent #7,503,150 & Patent Pending

Material Composition

Track Material: ASTM A1003/A1003M Structural Grade 50 (340) Type H, ST50H (ST340H): 50ksi (340MPa) minimum yield strength, 65ksi (450MPa) minimum tensile strength, 97mil minimum thickness (12 gauge, 0.1017" design thickness) with ASTM A653/A653M G60 (Z180) hot dipped galvanized coating.

Headed Stud Material: ASTM A29/A108, Grades 1010 through 1020 or equivalent, 45ksi (310MPa) minimum yield strength, 55ksi (380MPa) minimum tensile strength, 3/8" diam. x 3 1/8" length with 3/4" head diameter.

Clip Material: DriftTrak Headed Stud - PTS can be used with DTSLB-PTS and DTLB-PTS clips: ASTM A1003/A1003M Structural Grade 50 (340) Type H, ST50H (ST340H): 50ksi (340MPa) minimum yield strength, 65ksi (450MPa) minimum tensile strength, 97mil minimum thickness (12 gauge, 0.1017" design thickness) with ASTM A653/A653M G90 (Z275) hot dipped galvanized coating.

Track Nomenclature

DriftTrak® Headed Stud - PTS comes in 12' lengths, with headed studs in a single row (See drawing below). To specify DriftTrak, list "DTH-PTS," followed by the length.

Example: DriftTrak® DTH-PTS – 12ft.

DTLB-PTS & DTSLB-PTS

DriftTrak® Headed Studs are to be installed with DriftTrak Bypass clips DTLB-PTS and DTSLB-PTS to better facilitate panel installation while accommodating vertical deflection and lateral drift requirements in floor slab bypass conditions. DriftTrak Connectors are sold separately.

Connector Nomenclature

DriftTrak DTLB-PTS & DTSLB-PTS are made for 6" studs. They are classified by multiplying stud depth by 100, followed by "PTS," then "-L" for a Left version or "-R" for a Right version.

Example: Vertical Deflection required, left version required for installation

Designate: DriftTrak® DTSLB600-PTS-L

* Clips shown are left versions of DriftTrak DTLB-PTS & DTSLB-PTS. Right side versions are available for order as standard parts.

** Clips and track sold separately.



DriftTrak® Headed Stud - PTS: Dimensions, Layout and Stud Spacing

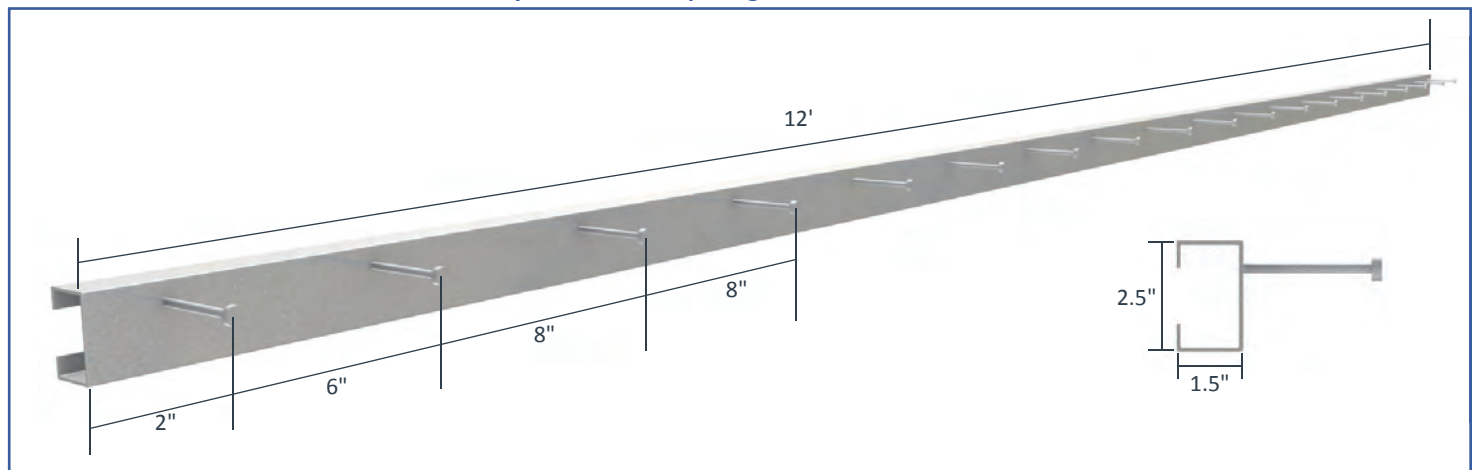

DriftTrak Headed Stud - PTS Allowable Loads

DriftTrak® Headed Stud - PTS with DTSLB600-PTS, Recommended Allowable Load (lbs): F2 DriftTrak® Headed Stud - PTS with DTLB600-PTS, Recommended Allowable Load (lbs): F2 & F3							
Stud		F2 Allowable Loads				F3 Allowable Loads	
		DTSLB600-PTS		DTLB600-PTS		DTLB600-PTS <i>Offset = 1.875" max</i>	
Thickness Mils (ga)	Yield Strength (ksi)	w/2 #12 Screws	w/3 #12 Screws	w/4 #12 Screws	w/6 #12 Screws	w/4 #12 Screws	w/6 #12 Screws
33 (20)	33	377	565	754	1,130	256	313
33 (20)	50	544	817	1,089	1,136	370	452
43 (18)	33	561	841	1,122	1,136	381	465
43 (18)	50	810	1,080	1,136	1,136	551	672
54 (16)	33	789	1,080	1,136	1,136	536	655
54 (16)	50	1,080	1,080	1,136	1,136	775	945
68 (14)	50	1,080	1,080	1,136	1,136	1,064	1,064
97 (12)	50	1,080	1,080	1,136	1,136	1,064	1,064
Max Allowable Clip Load		1,080		1,136		1,064	

Load Direction

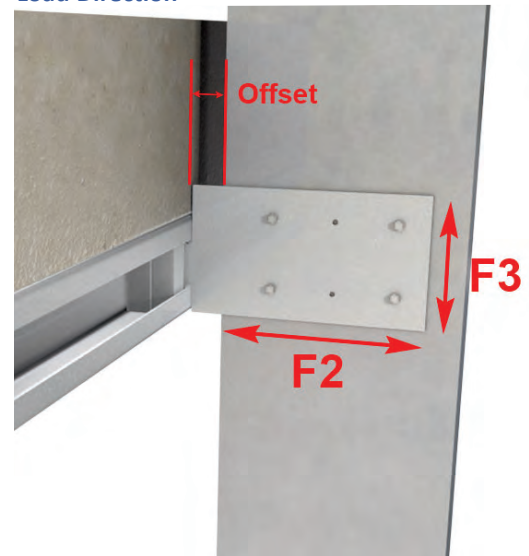

Notes:

- Recommended ASD steel strength per headed stud in tension or shear = 1,600 lbs. Designers must check headed stud tension and shear anchorage capacity in concrete per ACI 318 based on actual headed stud edge distance and concrete compressive strength. For more information, call TSN Technical Support at 1-888-474-4TSN.
- Allowable load tables incorporate eccentric loading of fasteners.
- Loads listed reflect force in a single direction. When multiple loads react on the connection, it is the responsibility of the designer to check the interaction of forces.
- Torsional effects are considered on screw group for F3 allowable loads. It is assumed that all of the torsional moment is taken by the connection to the stud.
- Design loads are for attachment of DriftTrak to stud only. Load tables reflect horizontal loads (F2) and vertical loads (F3)
- Allowable loads have not been increased for wind, seismic, or other factors.
- Clips are manufactured to fit into the DriftTrak and provide a rigid/slip connection to the stud, and free lateral movement of the structure.
- One row of bridging is recommended at a maximum distance of 18" from DriftTrak if no other stud lateral restraint is present.

Fastener Patterns

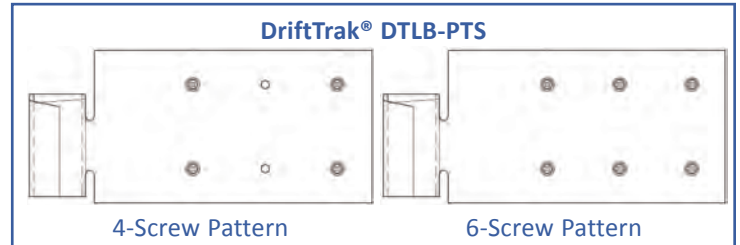
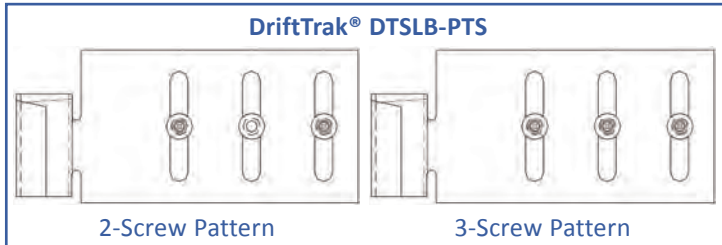

Example Details

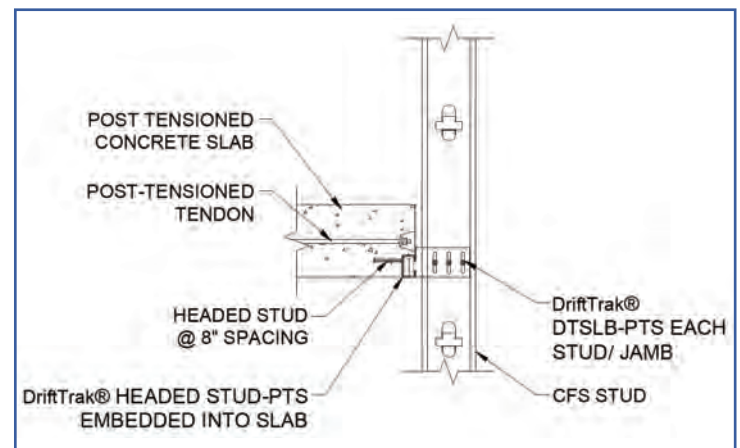
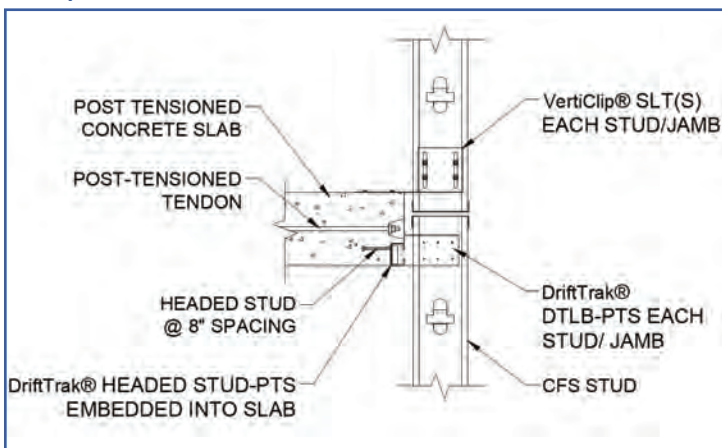

**DriftTrak® DTLB-PTS with Headed Studs:
Attachment to Post-Tensioned Concrete Slab**

**DriftTrak® DTSLB-PTS with Headed Studs:
Attachment to Post-Tensioned Concrete Slab**