

# StiffClip® HE

Header Connector



### Material Composition

**HE(L):** ASTM A1003/A1003M Structural Grade 50 (340) Type H, ST50H (ST340H): 50ksi (340MPa) minimum yield strength, 65ksi (450MPa) minimum tensile strength, 43mil minimum thickness (18 gauge, 0.0451" design thickness) with ASTM A653/A653M G90 (Z275) hot dipped galvanized coating.

**HE(H) & HE(S):** ASTM A1003/A1003M Structural Grade 50 (340) Type H, ST50H (ST340H): 50ksi (340MPa) minimum yield strength, 65ksi (450MPa) minimum tensile strength, 68mil minimum thickness (14 gauge, 0.0713" design thickness) with ASTM A653/A653M G90 (Z275) hot dipped galvanized coating.

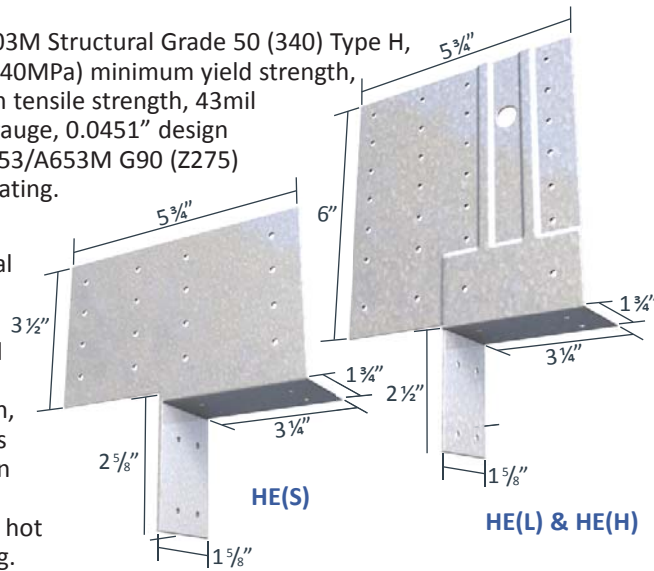

### StiffClip HE Allowable Loads: Screw Fasteners

StiffClip® HE Recommended Allowable Load for a Single Clip (lbs): F3

Stud		HE(L)						HE(H)					
Thickness Mils (ga)	Yield Strength (ksi)	w/8 #10 screws	w/12 #10 screws	w/16 #10 screws	w/20 #10 screws	w/24 #10 screws	w/28 #10 screws	w/8 #10 screws	w/12 #10 screws	w/16 #10 screws	w/20 #10 screws	w/24 #10 screws	w/28 #10 screws
33 (20)	33	536	708	873	1,090	1,239	1,340	536	708	873	1,090	1,239	1,340
33 (20)	50	774	1,021	1,259	1,573	1,787	1,933	774	1,021	1,259	1,573	1,787	1,933
43 (18)	33	797	1,052	1,297	1,620	1,841	1,991	797	1,052	1,297	1,620	1,841	1,991
43 (18)	50	1,151	1,520	1,873	2,340	2,659	2,876	1,151	1,520	1,873	2,340	2,659	2,876
54 (16)	33	1,121	1,480	1,824	2,279	2,590	2,801	1,121	1,480	1,824	2,279	2,590	2,801
54 (16)	50	1,518	2,004	2,470	3,066	3,066	3,066	1,618	2,136	2,633	3,289	3,738	4,042
68 (14)	50	1,518	2,004	2,470	3,066	3,066	3,066	2,012	2,656	3,274	4,090	4,648	5,026
97 (12)	50	1,518	2,004	2,470	3,066	3,066	3,066	2,012	2,656	3,274	4,090	4,648	5,026
<b>Max Allowable Clip Load</b>		<b>3,066</b>						<b>5,545</b>					

StiffClip® HE Recommended Allowable Load for a Single Clip (lbs): F3

StiffClip® HE Recommended Allowable Load for a Single Clip (lbs): F2

Stud		HE(S)			HE(L)			HE(H) & HE(S)		
Thickness Mils (ga)	Yield Strength (ksi)	w/8 #10 screws	w/12 #10 screws	w/16 #10 screws	w/4 #10 screws	w/6 #10 screws	w/8 #10 screws	w/4 #10 screws	w/6 #10 screws	w/8 #10 screws
33 (20)	33	382	501	611	199	299	399	199	299	399
33 (20)	50	551	722	880	287	431	575	287	431	575
43 (18)	33	568	744	907	296	444	592	296	444	592
43 (18)	50	821	1,075	1,311	428	627	627	428	641	855
54 (16)	33	799	1,047	1,276	417	625	627	417	625	833
54 (16)	50	1,153	1,511	1,842	564	627	627	601	902	1,088
68 (14)	50	1,434	1,879	2,291	564	627	627	747	1,088	1,088
97 (12)	50	1,434	1,879	2,291	564	627	627	747	1,088	1,088
<b>Max Allowable Clip Load</b>		<b>2,968</b>			<b>627</b>			<b>1,088</b>		

### Notes:

- Torsional effects are considered on screw group for F2 & F3 allowable loads. It is assumed that half of the torsional moment is taken by the connection on one side and half is taken by the connection on the other side of the clip.
- Attachment to stud is made with screws symmetrically placed. All guide holes may not require fasteners. Fastener amount determined by designer.
- Allowable loads have not been increased for wind, seismic, or other factors.
- The minimum combination of steel thickness and yield strength must be used when determining the maximum design load.
- Design loads listed consider both loads on the clip and the #10 screws as they are fastened to the steel beam and column or jamb and header members.

\* Refer to screw patterns on the following page.

### Load Direction



**Screw Patterns for HE(L) & HE(H) F3 Load Tables**

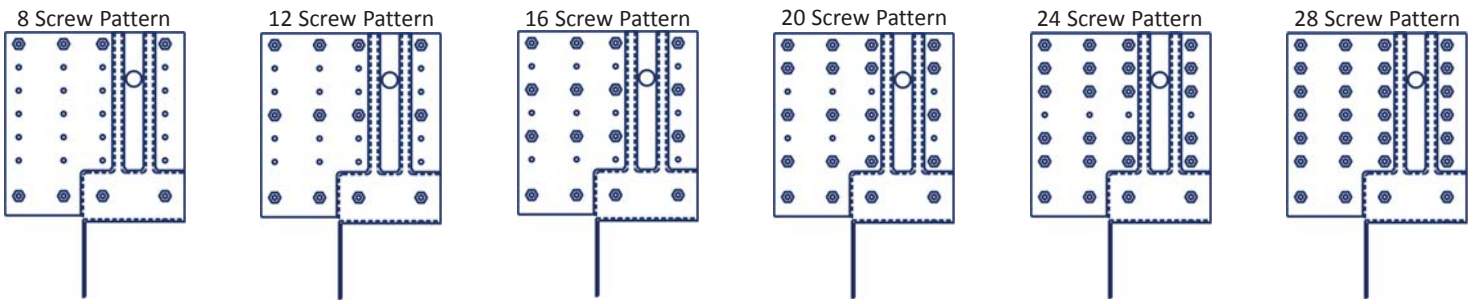

**Screw Patterns for HE(S) F3 Load Tables**

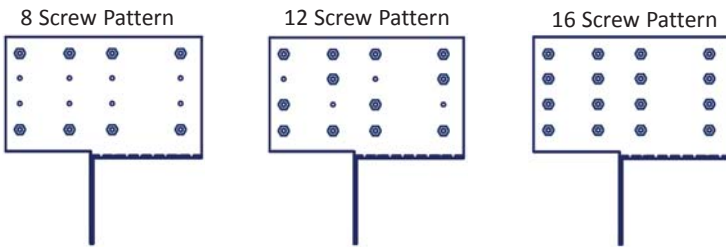

**Screw Patterns for F2 Load Tables**

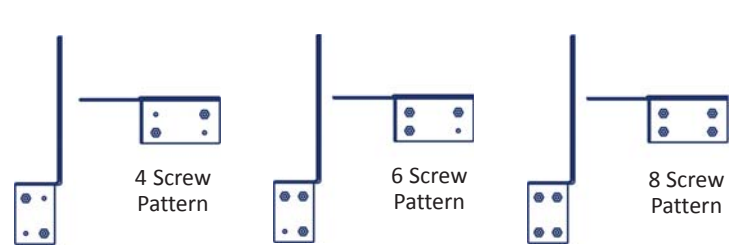

**Allowable Loads: Welded Connection**

StiffClip® HE Recommended Allowable Load for a Single Clip (lbs): F3		
Stud		HE(H)
Thickness Mils (ga)	Yield Strength (ksi)	Weld used to Header and Post Combined
54 (16) and thicker	50	4,177

**Notes:**

- The standard clip does not include the four large holes in the web of the clip. Customs can be ordered by request.
- Welded values do not apply to 43mil (18ga) StiffClip HE.
- HE(H) with welds around the perimeter of four 0.375" diameter holes and along each side of the clip. Weld size not to exceed double the material thickness of the header or jamb, or 1/8"; and care should be taken to not burn through the material.

**Nomenclature**

StiffClip HE is available in two thicknesses. The StiffClip HE(L) is 43mil (18ga), and the StiffClip HE(H) & HE(S) are both 68mil (14ga).

\* Clips are packaged as pairs. Four StiffClip HE clips are used at each opening: two left-hand and two right-hand clips attach the complete header to the jamb.

**Weld Diagram**

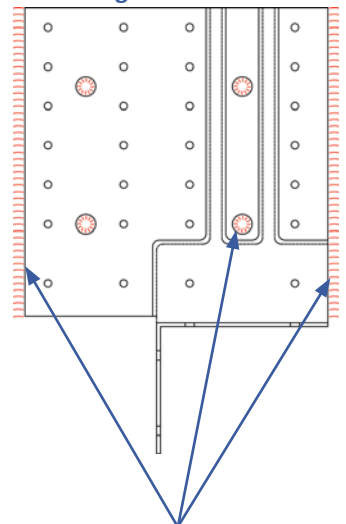

1/8" weld around four 0.375" diameter holes, with 1/8" welds along each side.

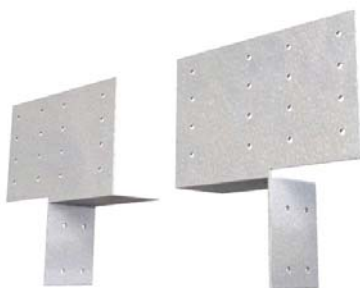

HE(S)



HE(L) & HE(H)

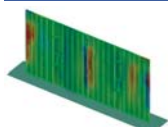

StiffClip HE Series  
Blast and Seismic Design data  
www.steelnetwork.com

\*\* For more information or to review a copy of this report, please visit our website at <http://www.steelnetwork.com/Site/TechnicalData>