

StiffClip® LS

Spandrel/Multi-Purpose



Material Composition

ASTM A1003/A1003M Structural Grade 50 (340) Type H, ST50H (ST340H): 50ksi (340MPa) minimum yield strength, 65ksi (450MPa) minimum tensile strength, 68mil minimum thickness (14 gauge, 0.0713" design thickness) with ASTM A653/A653M G90 (Z275) hot dipped galvanized coating.

The attachment of StiffClip to the primary structure may be made with PAFs, screw/bolt anchors or weld and is dependent upon the base material (steel or concrete) and the design configuration.

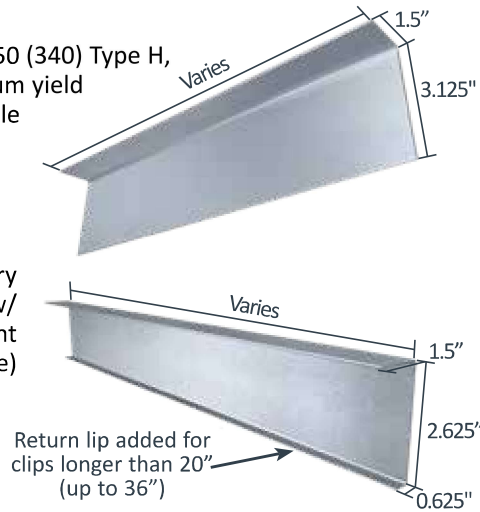

Material Analysis

StiffClip® LS Section Properties							
Designation	Area (in ²)	I _x (in ⁴)	I _y (in ⁴)	R _x (in)*	R _y (in)**	S _x (in ³)	S _y (in ³)
StiffClip® LS < 20" Length	0.322	0.341	0.057	1.029	0.419	0.168	0.046
StiffClip® LS > 20" Length	0.323	0.308	0.055	0.978	0.413	0.198	0.046

Notes:

1. StiffClip LS resists axial tension and ocmpression loads.
2. Allowable design loads may be calculated based on the section properties shown above.
3. Lengths greater than 20" incorporate a stiffening lip to increase compressive strength.
4. For powder actuated fasteners, fasten within 3/4" from the angle heel centerline of the 1-1/2" leg.

* Rx = Radius of Gyration about x-x axis.
 ** Ry = Radius of Gyration about y-y axis.

Nomenclature

StiffClip LS is available in various lengths. To calculate length for spandrel wall connectors, add stud depth, 3" for attachment to steel (5.5" for attachment to concrete), and the distance of construction tolerance. For other applications, simply designate length (in.) multiplied by 100.

Example: 6" stud depth, 4" attachment to structure, 2" tolerance (6+4+2=12)
Designate: StiffClip® LS1200

Example Details

