

ICC-ES Evaluation Report

ESR-1903

Reissued November 1, 2008

This report is subject to re-examination in two years.

www.icc-es.org | (800) 423-6587 | (562) 699-0543

A Subsidiary of the International Code Council®

DIVISION: 05—METALS
Section: 05090—Metal Fastenings
Section: 05400—Cold-formed Metal Framing

DIVISION: 09—FINISHES
Section: 09110—Non-load-bearing Metal Framing

REPORT HOLDER:

THE STEEL NETWORK, INC.
 2012 TW ALEXANDER DRIVE
 POST OFFICE BOX 13887
 DURHAM, NORTH CAROLINA 27709
 (919) 521-5502
www.steelnetwork.com
technicalsupport@steelnetwork.com

EVALUATION SUBJECT:

VERTICLIP® SL, SLB, SLS, AND SLT EXTERIOR CURTAIN-WALL STEEL STUD CONNECTORS, AND THE VERTICLIP® SLD INTERIOR HEAD-OF-WALL STEEL STUD CONNECTOR

1.0 EVALUATION SCOPE
Compliance with the following codes:

- 2006 *International Building Code*® (IBC)
- 1997 *Uniform Building Code*™ (UBC)

Property evaluated:

Structural

2.0 USES
2.1 VertiClip® Curtain Wall Connectors:

VertiClip® SL, SLB, SLS, and SLT cold-formed steel connectors are used to attach the steel studs of a building's exterior curtain wall to structural members, and are designed to transfer wind or earthquake loads acting perpendicular to the exterior curtain wall and to accommodate vertical movement between exterior wall elements and the primary structure.

2.2 VertiClip® Top-of-wall Connector:

The VertiClip® SLD cold-formed steel connector is used to attach the top of interior nonload-bearing steel studs (top-of-wall connection) to the building's structural floor/ceiling or roof/ceiling deck, and is designed to transfer loads acting perpendicular to the interior nonload-bearing wall and to

accommodate vertical movement of the building's floor/ceiling or roof/ceiling deck.

3.0 DESCRIPTION
3.1 VertiClip® SL, SLB, SLS, and SLT Exterior Curtain Wall Stud Connectors:

3.1.1 General: VertiClip model numbers correspond to the depth of the cold-formed steel stud attached to the VertiClip; e.g., a VertiClip connector with a model number 362 is designed to be attached to a 3⁵/₈-inch-deep (92 mm) steel stud, where the depth of the steel stud is rounded to 3.62 and is reported as 362. Each VertiClip exterior curtain wall stud connector has two or more vertical slots with factory-installed bushings located in the center of each slot, through which a #12–14x1 self-drilling, tapping steel screw is installed to attach the clip to the stud, allowing horizontal loads to be transferred from the stud web to the supporting structure while allowing vertical movement of the structure with negligible friction. The Steel Network, Inc., supplies the required number of screws with each clip for attachment to steel studs. Fasteners used to attach the clips to the supporting structure must be designed and specified by a registered design professional.

3.1.2 VertiClip® SL: VertiClip SL362, 600 and 800 are L-shaped angles that connect 3⁵/₈-, 6- and 8-inch-deep (92, 152, and 203 mm) exterior curtain wall steel studs, respectively, at head of wall to the building's structural frame while allowing for a maximum of 1³/₈ inches (35 mm) for the VertiClip SL362 and 1¹/₂ inches (38.1 mm) for the VertiClip SL600 and SL800 of vertical movement between exterior wall elements and the primary structure. The minimum base-metal thickness of the clips is 0.0677 inch (1.7 mm). The long leg of the VertiClip SL362 connector, which is fastened to the curtain wall stud, has two vertical slots, each 3³/₈ inch (9.5 mm) wide by 1³/₄ inches (44.5 mm) long. The long leg of the VertiClip SL600 and SL800 connectors has two or three vertical slots, each 3³/₈ inch (9.5 mm) wide by 1⁷/₈ inches (47.6 mm) long. Refer to Figure 1 for overall dimensions of each VertiClip SL connector and a typical installation detail.

3.1.3 VertiClip® SLB: The VertiClip SLB600 is an L-shaped angle that connects 6-inch-deep (152 mm) exterior curtain wall steel studs to a concrete floor slab's pour stop angle while allowing a maximum of 2 inches (51 mm) of vertical movement between exterior wall elements and the primary structure. The minimum base-metal thickness of the clip is 0.0677 inch (1.7 mm). The long leg of the connector, which is fastened to the curtain wall stud, has three vertical slots, each 3³/₈ inch (9.5 mm) wide by 2³/₈ inches (60.3 mm) long. Refer to Figure 2 for overall dimensions of the VertiClip SLB600 connector and a typical installation detail.

3.1.4 VertiClip® SLS: The VertiClip SLS600–12 is an L-shaped angle that connects 6-inch-deep (152 mm) exterior curtain walls to a building's structural steel spandrel beam or structural concrete floor slab, while allowing for a maximum of 1½ inches (38 mm) of vertical movement between exterior wall elements and the primary structure. The minimum base-metal thickness of the clip is 0.0677 inch (1.7 mm). The designation –12 following the model number SLS600 represents the total length, in inches, of the connector. The end of the connector that is attached to the curtain wall framing members has two or three vertical slots, each ¾ inch (9.5 mm) wide by 1⅞ inches (47.6 mm) long. Refer to Figure 3 for overall dimensions of the Verticlip SLS600–12 connector and a typical installation detail.

3.1.5 VertiClip® SLT: VertiClip SLT–9.5 and SLT(L)–18 are formed steel plates having one upward and one downward vertical leg at the end of the connectors that attach to the curtain wall framing members. The minimum base-metal thickness of the plates is 0.0966 inch (2.5 mm). Each leg of the SLT–9.5 is 1½ inches (38 mm) wide by 2¼ inches (57 mm) high, and has one vertical slot measuring 5/16 inch (8 mm) wide by 1⅜ inches (35 mm) long, allowing for a maximum 1-inch (25.4 mm) vertical movement of the framing members. Each leg of the SLT(L)–18 is 2⅜ inches (71 mm) wide by 3⅞ inches (79 mm) high, and has two vertical slots measuring ¾ inch (9.5 mm) wide by 2¼ inches (57 mm) long, allowing for a maximum of 1⅞ inches (47.6 mm) of vertical movement between exterior wall elements and the primary structure. The bend in the steel plate at the vertical legs of the SLT(L)–18 is reinforced with two ¾-inch-by-5/8-inch (9.5 mm by 15.9 mm) L-shaped steel angles that are factory-attached with four 3/16-inch-diameter (4.8 mm) rivets. The angle reinforcement is 4⅜ inches (111 mm) long and has a minimum base-metal thickness of 0.0677 inch (1.7 mm). Refer to Figure 4 for overall dimensions of the Verticlip SLT–9.5 and SLT(L)–18 connectors and a typical installation detail.

3.2 VertiClip® SLD Interior Wall Stud Connector:

The VertiClip SLD600 is an L-shaped angle that connects the top end of 6-inch-deep (152 mm) interior wall steel studs to a metal deck above, while allowing for a maximum 1½-inch (38 mm) vertical movement. The minimum base-metal thickness of the clip is 0.0329 inch (0.8 mm). The long leg of the VertiClip SLD600 connector, which is fastened to the web of the interior wall steel stud, has two vertical slots, each ¾ inch (9.5 mm) wide by 1⅞ inches (47.6 mm) long. Each vertical slot has a factory-installed bushing located in the center of the slot, through which a #8–18x¾ self-drilling, tapping steel screw is installed to attach the clip to the stud, allowing horizontal loads to be transferred from the stud web to the supporting structure while permitting for vertical movement of the structure with negligible friction. The Steel Network, Inc., supplies the required number of steel screws with each clip for attaching it to the steel studs. Refer to Figure 5 for overall dimensions of the Verticlip SLD600 connector and a typical installation detail.

3.3 Materials:

3.3.1 VertiClips: The VertiClip connectors described in this report are manufactured from ASTM A 653 SS, Grade 50, Class 1 steel. There is a minimum G90 zinc-coating designation for VertiClip® SL, SLB, SLS, and SLT Exterior Curtain Wall Stud Connectors, and a minimum G60 zinc-coating designation for the VertiClip® SLD600 Interior Wall Stud Connector.

3.3.2 Bushings: The bushings are factory-installed on each VertiClip product, and are not available separately for field

installation. The bushings are proprietary, and are fabricated from carbon steel conforming to ASTM B 783-04, Class 3, having a minimum specified yield strength of 35 ksi (240 MPa), as stipulated in the approved quality documentation.

3.3.3 Screws: Screws used with VertiClip series must be self-drilling, tapping steel screws, as follows:

- The #8–18x¾ self-drilling, tapping metal screws used with the Verticlip SLD600 must have a minimum nominal screw shear strength, P_{ss} , of 1.34 kips (5960 N).
- The #12–14x1 self-drilling, tapping metal screws used with the Verticlip SLS600–12, SLB600, SL362, SL600, SL800, SLT–9.5 and SLT(L)–18 must have a minimum nominal screw shear strength, P_{ss} , of 2.21 kips (9830 N).

3.3.4 Cold-formed Steel Studs: The design loads specified in this evaluation report are based on the assumption that the connected steel studs have a minimum base-metal thickness of 0.097 inch (2.5 mm) and are fabricated from cold-formed steel complying with ASTM A653 Grade 50 (340), with minimum specified yield and tensile strengths of 50 ksi (340 MPa) and 65 ksi (450 MPa), respectively.

4.0 DESIGN AND INSTALLATION

4.1 Design:

Table 1 of this report presents the following design information: (1) The calculated safety factor, Ω , and resistance factor, ϕ , as derived in accordance with the AISI (2001) North American Specification for the Design of Cold-formed Steel Structural Members, including the 2004 Supplement (AISI-NAS); (2) the average test load at 1/8-inch (3.2 mm) deflection service limit; (3) the Allowable Strength Design (ASD) loads for the VertiClip products described in this report; and (4) the Load and Resistance Factor Design (LRFD) design strength for the VertiClip products described in this report. Refer to Figures 1 through 5 for the direction of load listed in Table 1.

The connection of the Verticlip product to the supporting structure must have a design load or factored resistance not less than the allowable load or design strength assigned to the Verticlip products in Table 1 of this report. The design of the connection must be submitted to the code official for approval.

When using the alternate basic load combinations in IBC Section 1605.3.2 (or UBC Section 1612.3.2) that include wind or earthquake loads, the ASD allowable loads in Table 1 for the VertiClip connectors must not be increased by 33⅓ percent, nor must the alternative basic load combinations be reduced by a factor of 0.75. When using the basic load combinations in accordance with IBC Section 1605.2.1 (or UBC Section 1612.2.1), the LRFD nominal strength in Table 1 for the VertiClip connectors must not be increased for wind or earthquake loading.

If the steel studs connected to VertiClip connectors have lower base-metal thickness or material strength values than specified in Section 3.3.4, the ASD allowable loads or the LRFD design strength of the steel-stud/VertiClip-screw connection may be calculated according to the AISI cold-formed steel specification referenced by the applicable code [for the IBC: AISI-NAS; and for the UBC: Chapter 22, Division VII of the UBC], but not to exceed the corresponding loads listed in Table 1.

4.2 Installation:

Installation of the VertiClip products must comply with this report and the manufacturer's published installation instructions.

5.0 CONDITIONS OF USE

The Verticlip products described in this report comply with, or are suitable alternatives to what is specified in, those codes listed in Section 1.0 of this report, subject to the following conditions:

- 5.1 Drawings and design details verifying compliance with this report must be submitted to the building official for approval. The drawings and calculations must be prepared by a registered design professional when required by the statutes of the jurisdiction in which the project is to be constructed.
- 5.2 The products must be identified in accordance with this report.
- 5.3 The products must be installed in accordance with this report and the manufacturer’s published installation instructions.

6.0 EVIDENCE SUBMITTED

Data in accordance with the ICC-ES Acceptance Criteria for Connectors Used with Cold-formed Steel Structural Members (AC261), dated October 2004 (editorially revised January 2008).

7.0 IDENTIFICATION

The VertiClip products described in this report must be stamped, labeled, or inked with the product designation and the company name (The Steel Network, Inc.). Each box label must include the company name (The Steel Network, Inc.), product designation/part name, quantity, the ICC-ES evaluation report number (ESR-1903), and a traveler (tracing) number.

TABLE 1—VERTICLIP ALLOWABLE STRESS DESIGN (ASD) LOADS, LOAD AND RESISTANCE FACTOR DESIGN (LRFD) NOMINAL STRENGTH, AND DEFLECTION SERVICE LIMIT LOADS¹

VERTICLIP MODEL	SCREWS ² (NUMBER) AND SIZE	ASD ALLOWABLE LOAD ⁴ (lbf)	LRFD DESIGN STRENGTH ⁵ (lbf)	SERVICE LIMIT LOAD ⁶ (lbf)
SL362	(2) #12–14x1	790	1,700	790
SL600	(3) #12–14x1	1,680	2,690	3,440
SL800	(3) #12–14x1	1,870	2,990	4,570
SLB600	(3) #12–14x1	1,600	2,560	1,680
SLS600–12	(3) #12–14x1	2,070	3,315	3,240
SLT–9.5	(2) #12–14x1	510	820	1,280
SLT(L)–18	(4) #12–14x1	700	1,120	1,440
SLD600	(2) #8–18x ³ / ₄	405	650	1,170

For **SI**: 1 lbf = 4.45 N.

¹Refer to Figures 1 through 5 for direction of load.

²Screws must comply with Section 3.3.3 of this report, and must be installed in the prepunched holes and bushings provided in the connectors.

³When using the alternate basic load combinations in IBC Section 1605.3.2 (or UBC Section 1612.3.2) that include wind or earthquake loads, the tabulated ASD allowable loads for the VertiClip connectors must not be increased by 33¹/₃ percent, nor can the alternative basic load combinations be reduced by a factor of 0.75.

⁴When using the basic load combinations in accordance with IBC Section 1605.2.1 (or UBC Section 1612.2.1), the tabulated LRFD nominal strength for the VertiClip connectors must not be increased for wind or earthquake loading.

⁵The Service Limit Load is the average test load at a ¹/₈-inch deflection limit. The service limit is applicable to both ASD and LRFD.

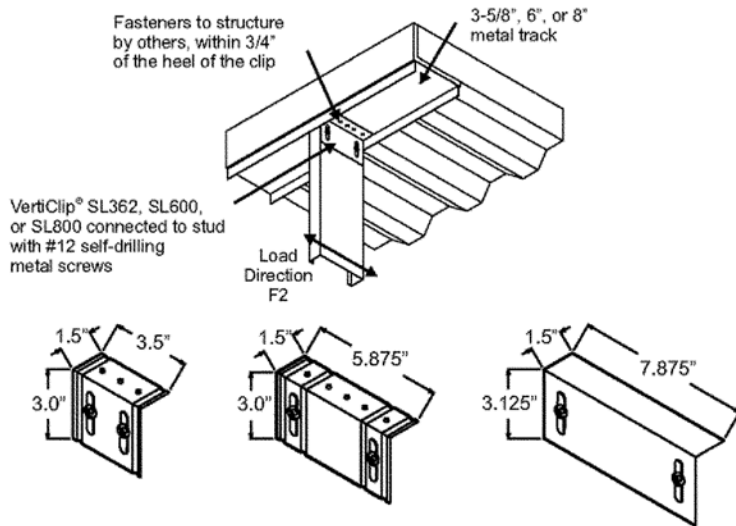

FIGURE 1 - VERTICLIP SL362, SL600, and SL800

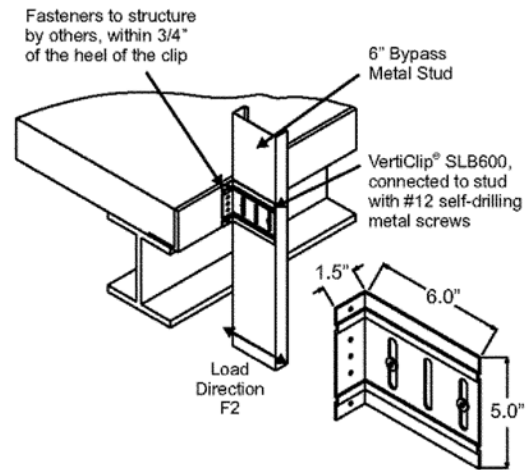

FIGURE 2 - VERTICLIP SLB600

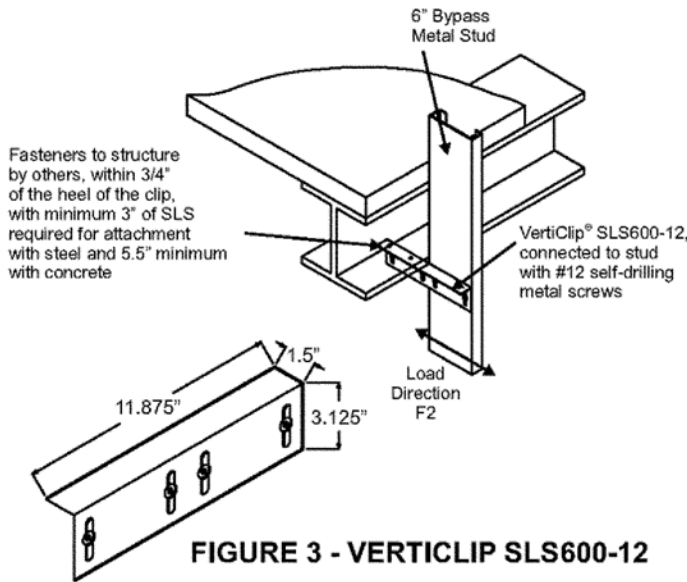

FIGURE 3 - VERTICLIP SLS600-12

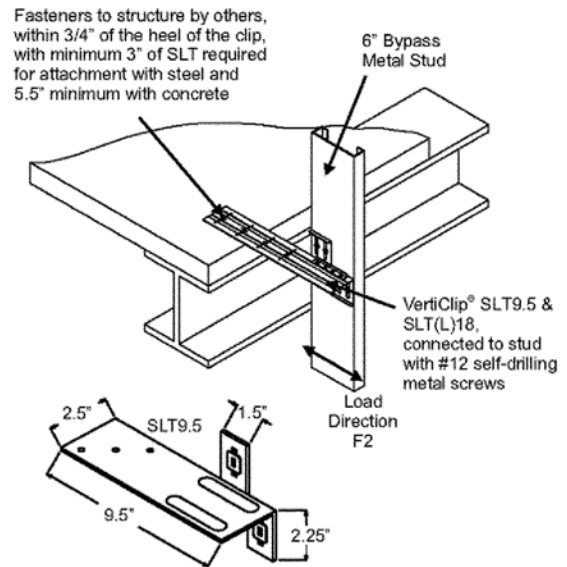

FIGURE 4 - VERTICLIP SLT-9.5 AND SLT(L)18

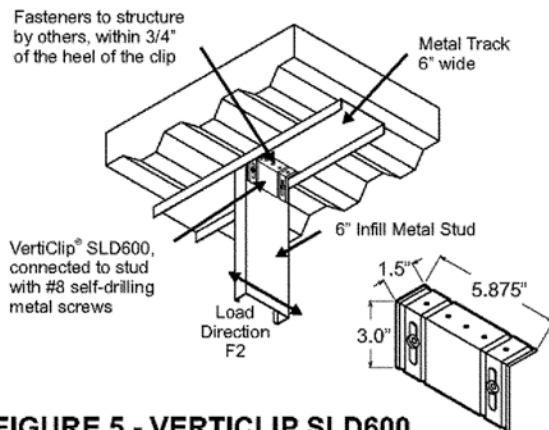

FIGURE 5 - VERTICLIP SLD600