

# Shear Wall Systems

# TightStrap® Strap Tensioner

## Product Description

The pre-tensioning of a shear wall flat strap provides a means to ensure the shear wall will perform as designed. It is important that the flat straps are as tight as possible when installed to achieve optimal system performance.

TightStrap® is a unique device used to tension (tighten) flat strap in the field. Use TightStrap to improve structural performance of a shear wall by removing "waviness" or "bowing" prior to fastening.

TightStrap is designed to be used in both StiffWall® and generic flat strap shear walls. TightStrap's track connector fastens to standard track at the corners of the shear wall to provide a base for the tensioning process. It is preferable to tighten the flat straps after applying some vertical load (own weight) on top of the shear wall panel.

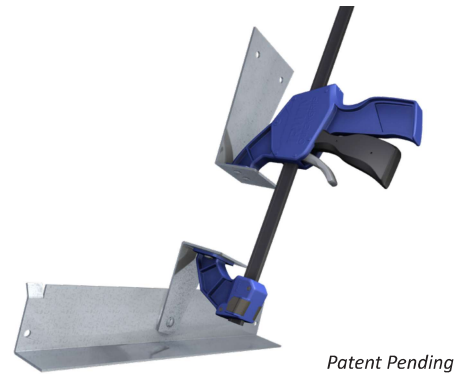

Patent Pending

## Using TightStrap®

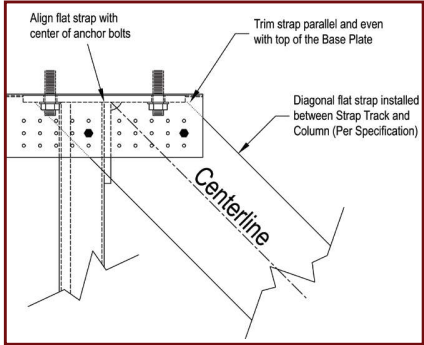

**Step 1** - Align & trim flat strap at each corner, attach one end with at least 2 screws.

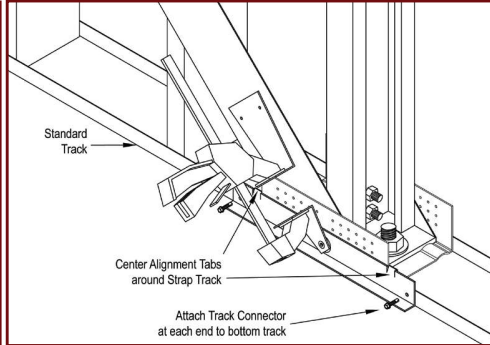

**Step 2** - Align Track Connector and attach to track.

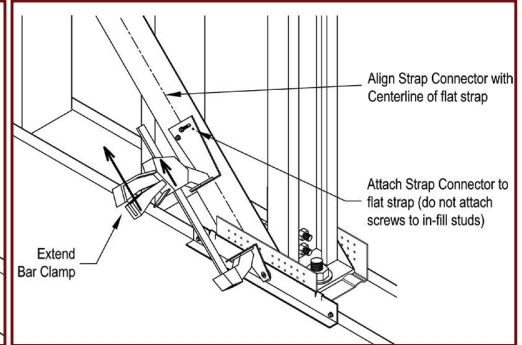

**Step 3** - Extend Bar Clamp, align Strap Connector with centerline of flat strap and attach Strap Connector to the flat strap.

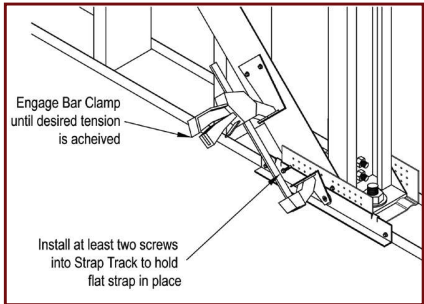

**Step 4** - Engage Bar Clamp, install at least 2 screws for flat strap attachment, remove TightStrap and install remaining screws for strap attachment.

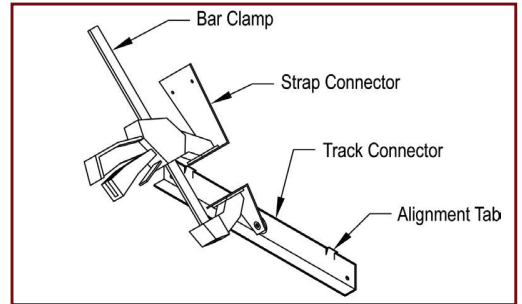

## How to Install the StiffWall® Shear Wall:

The boots are attached to the foundation or floor and the roof or ceiling with approved anchors or bolts as determined and approved by the Engineer (Boots are made up of the Strap Track and the "T" shaped Base Plate)

- Light, Plus, Small & Medium Boots utilize a 7/8" anchor bolt or threaded rod.
- Transition and Large Boots utilize a 7/8" anchor bolt or threaded rod on boots less than or equal to 4". Boots greater 4" contain guide holes for 1 1/4" anchor bolt or threaded rod.
- Attach the Flat Strap to the Strap Track, corner to corner, on both sides (4 straps needed) with the specified amount of #12 screws (or weld). The use of low profile screws help to reduce a "bump out" of finished sheetrock. To achieve the designed loads, the strap should be tight from corner to corner (with no slack). This is done by tightening the strap after the wall is loaded with a TightStrap® tool.

