

# VertiClip® SLB Installation Instructions

## Vertical Deflection @ Bypass Slab

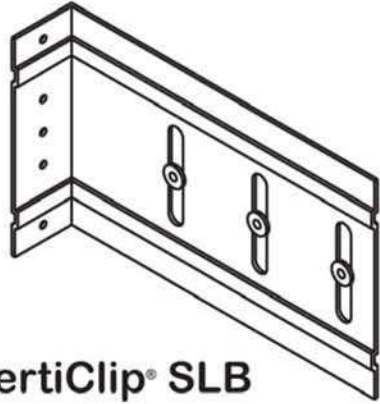

**VertiClip® SLB**



Step Bushings are pre-installed. Do not remove unless otherwise indicated.

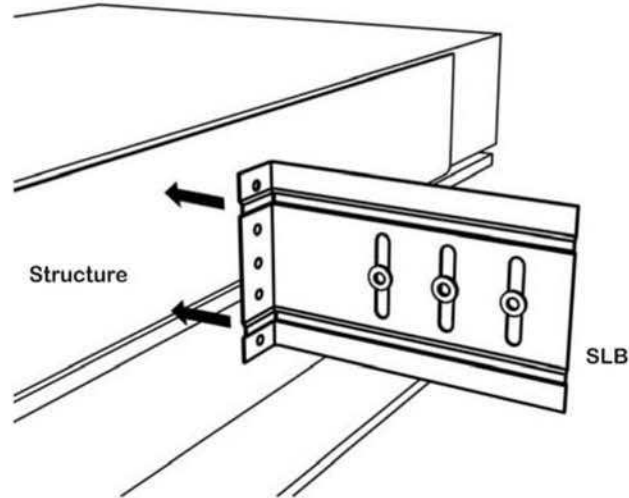

Refer to Design Drawings for Fastener type, size, and quantity

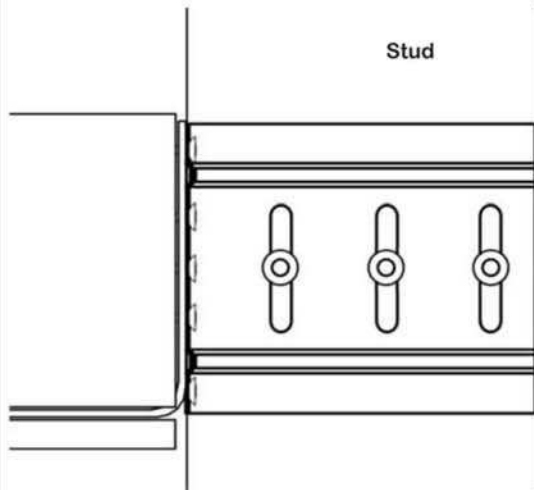
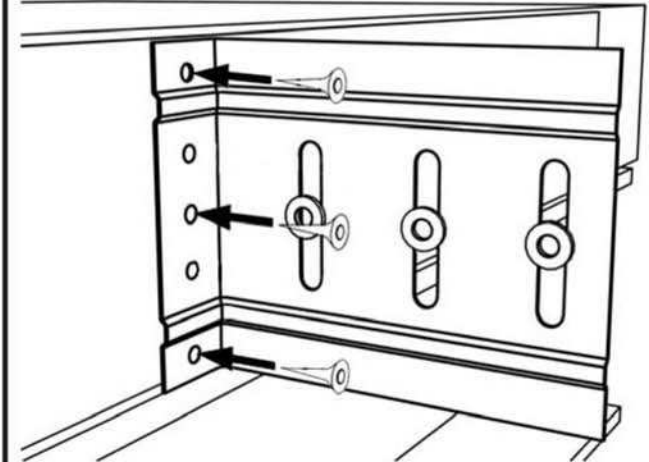

Install screws using a screw gun that does not exceed 2,500 rpm.

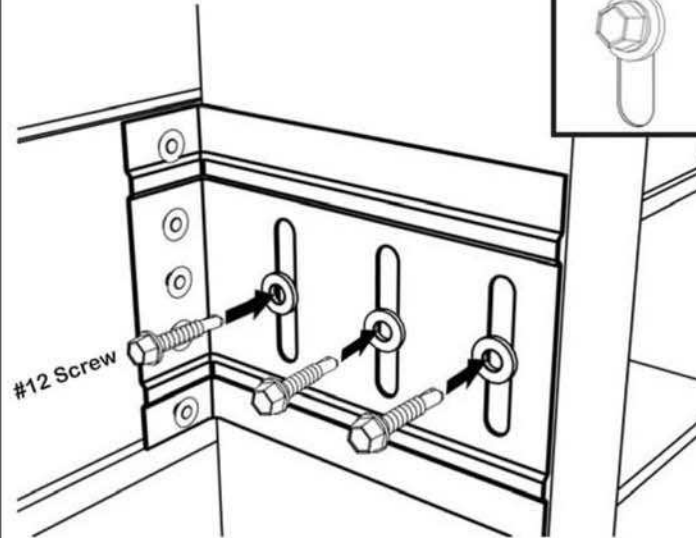

Screw gun must be equipped with torque limiting clutch to avoid fastener overdrive.

For Installation, Technical, or Submittal questions, contact TSN at (888) 474-4876.

Email us at [support@steelnetwork.com](mailto:support@steelnetwork.com)

Visit [www.steelnetwork.com](http://www.steelnetwork.com) and discover the value of each TSN Solution.