

# VertiClip® SL/SLD Installation Instructions

## Vertical Deflection @ Head of Wall

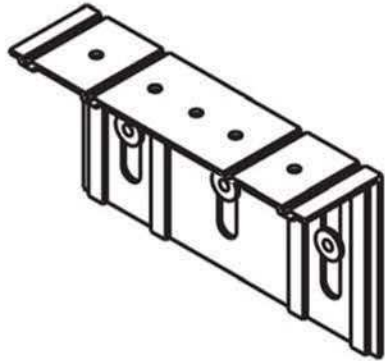

**VertiClip® SL/SLD**



Standard Step Bushing  
(Do not remove from slots unless otherwise directed)

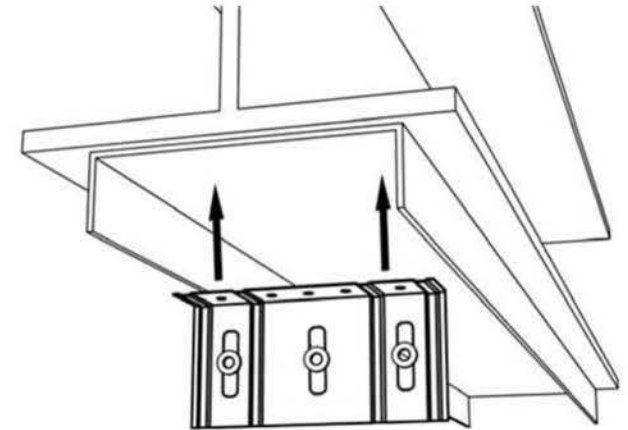
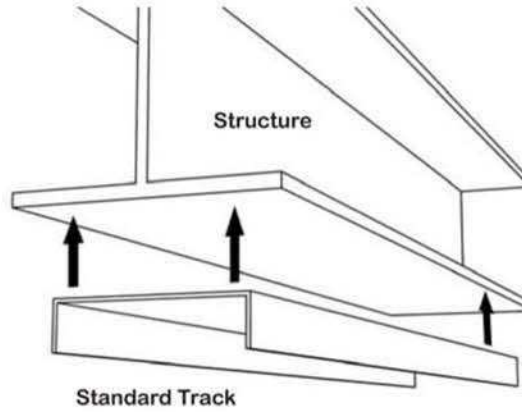

Attachment to Structure per Design Specifications

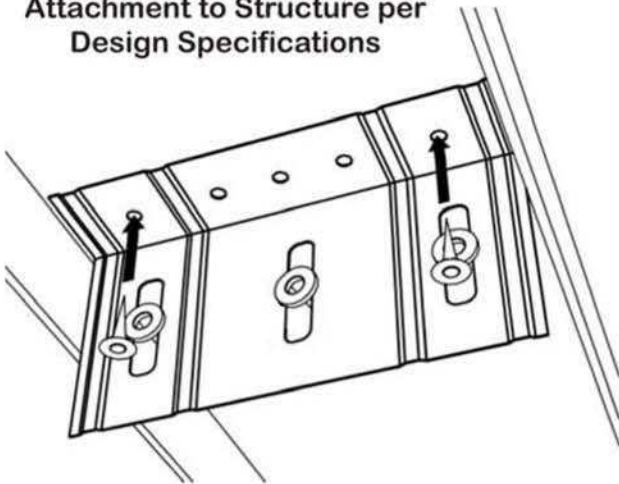

\* VertiClip SL600 Shown, Number of Slots May Vary

Deflection Gap

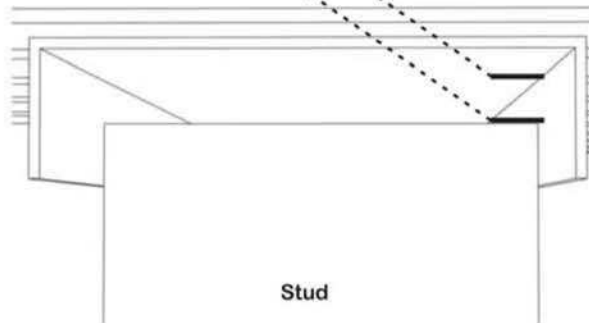

Install screws using a screw gun that does not exceed 2,500 rpm.

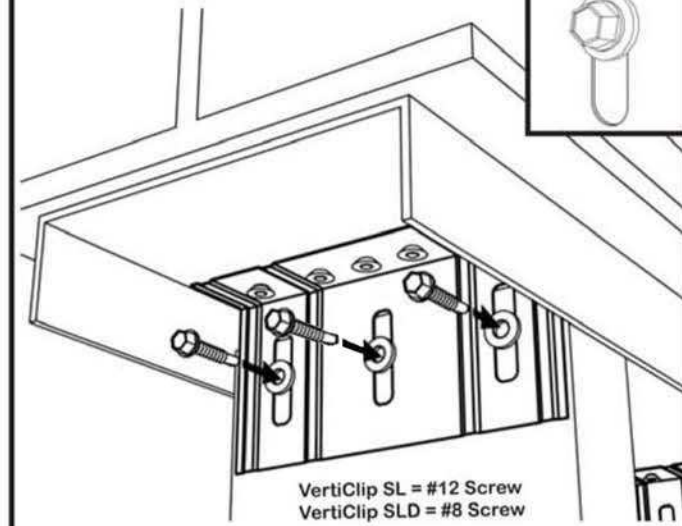

Screw gun must be equipped with torque limiting clutch to avoid fastener overdrive.