

UL Evaluation Report

UL ER2919-02

Issued: April 25, 2014

Revised: August 16, 2019

Visit UL, LLC's [Product iQ™ database](#) for the status of this Report.

UL Category Code: ULEZ

CSI MasterFormat®

DIVISION: 07 00 00 – THERMAL AND MOISTURE PROTECTION

Sub-level 2: 07 30 00 – Steep Slope Roofing

Sub-level 3: 07 31 00 – Shingles and Shakes

Sub-level 4: 07 31 13 – Asphalt Shingle

COMPANY:

TAMKO BUILDING PRODUCTS LLC
220 WEST FOURTH STREET
JOPLIN, MISSOURI 64801
(417) 624-6644
www.tamko.com

1. SUBJECT: Asphalt Shingles

ELITE GLASS-SEAL

HERITAGE, HERITAGE IR, HERITAGE PREMIUM, HERITAGE WOODGATE, HERITAGE VINTAGE,

HERITAGE VINTAGE 12 X 12 HIP AND RIDGE, 12-¼ X 12 HIP AND RIDGE AND 12-¼ X 12
HERITAGE HIP AND RIDGE IR

2. SCOPE OF EVALUATION

- 2018, 2015, 2012, and 2009 *International Building Code*® (IBC)
- 2018, 2015, 2012, and 2009 *International Residential Code*® (IRC)
- ICC ES Acceptance Criteria for Quality Documentation (AC10), Dated January 2018
- ICC ES Acceptance Criteria for Alternative Asphalt Roofing Shingles (AC438), Dated June 2017



The products were evaluated for the following properties:

- Exterior Fire Exposure (ANSI/UL790, ASTM E108)
- Wind Resistance (ASTM D3161; ASTM D7158)
- Physical Properties (ASTM D3462, ICC ES AC438)
- Impact Resistance (ANSI/UL 2218)

3. REFERENCED DOCUMENTS

- ANSI/UL790 (ASTM E108), Standard Test Methods for Fire Tests of Roof Coverings Eighth Edition, dated October 19, 2018
- ANSI/UL 2218 Second Edition, Standard Test Methods for Impact Resistance of Prepared Roof Covering Materials
- ASTM D3161-15, Standard Test Method for Wind-Resistance of Asphalt Shingles (Fan-Induced Method)
- ASTM D7158-16, Standard Test Method for Wind Resistance of Asphalt Shingles (Uplift Force/Uplift Resistance Method)
- UL Subject 2375 Issue No. 2, Outline of Investigation for Hip and Ridge Shingles (UL Fire and Wind Tests)
- ICC ES Acceptance Criteria for Alternative Asphalt Roofing Shingles (AC438), Dated June 2017
- ICC ES Acceptance Criteria for Quality Documentation (AC10), Dated January 2018

4. USES

TAMKO asphalt shingles described in this report are alternatives to asphalt shingles complying [Section 1507.2.4](#) of the 2018 IBC and [Section 1507.2.5](#) of the 2015, 2012, and 2009 IBC and [Section R905.2.4](#) of the 2018, 2015, 2012, and 2009 IRC and are Class A roof coverings for new and existing roofs.

5. PRODUCT DESCRIPTION

TAMKO asphalt shingles are roof covering materials complying with the following properties when installed as described in this report. The products are three-tab shingles, laminated shingles and hip and ridge shingles. The products are available in standard and metric sizes.

Fire Classification: TAMKO asphalt shingles covered under this Report have been tested for fire classification Class A in accordance with UL 790 (ASTM E108). Shingles tested in accordance with UL790 (ASTM E108) qualify for use under [Section 1505.1](#) of the 2018, 2015, 2012, and 2009 IBC and [Section R902.1](#) of the 2018, 2015, 2012, and 2009 IRC.

Wind Resistance: TAMKO asphalt shingles covered under this Report have been tested for wind resistance in accordance with ASTM D3161 or ASTM D7158.

Shingles tested in accordance with ASTM D3161 are classified as Class F and qualify for use under the exception to [Section 1504.1.1](#) of the 2018 and 2015 IBC and [Section 1507.2.7.1](#) of the 2012, and 2009 IBC, or the exception to [Section R905.2.4.1](#) of the 2018, 2015, 2012, and 2009 IRC.

Shingles tested in accordance with ASTM D7158 are classified as Class H and qualify for use in locations as shown in [Table 1507.2.7.1](#) of the 2012 and 2009 IBC or [Table R905.2.4.1](#) of the 2012 and 2009 IRC, where the maximum basic wind speed is 150 mph (67 m/s) or less with exposure category of B or C (ASCE 7) and a maximum building height of 60 feet (18.3 m). Installation must be in accordance with [Section 1507.2.6](#) of the 2018 IBC and [Section 1507.2.7](#) of the 2015, 2012, and 2009 IBC, or [Section R905.2.6](#) of the 2018, 2015, 2012, and 2009 IRC, as applicable.

Physical Properties: TAMKO asphalt shingles covered under this Report have been tested for physical properties in accordance with ICC ES AC438. Shingles tested in accordance with ICC ES AC438 qualify

as an alternative roof covering for use under [Section 1507.2.4](#) of the 2018 IBC and [Section 1507.2.5](#) of the 2015, 2012, and 2009 IBC or [Section R905.2.4](#) of the 2018, 2015, 2012, and 2009 IRC. When installed on new construction in accordance with this report and the TAMKO Building Products LLC installation instructions, the shingles are a Class A roof covering. When the shingles are installed over existing roof coverings, the Class A fire classification is maintained.

5.1 Three-Tab Shingles – Elite Glass-Seal:

Elite Glass-Seal shingles are three-tab shingles manufactured with a single fiberglass mat, coated on both sides with asphalt, and surfaced on the weather-exposed side with mineral granules. The shingles are self-sealing and have beads of thermal-tab sealing adhesive above the shingle butt on the weather side. See [Table 2](#) for product dimensions and manufacturing locations.

5.2 Laminated Shingles – Heritage, Heritage IR, Heritage Premium, Heritage Woodgate, Heritage Vintage:

Heritage, Heritage IR, Heritage Premium, Heritage Woodgate and Heritage Vintage shingles are laminated shingles manufactured with a double layer of fiberglass mats coated with asphalt on all sides, and surfaced on the weather-exposed side with mineral granules. See [Table 3](#), [Table 4](#), [Table 5](#), [Table 6](#), [Table 7](#) and [Table 10](#) for product dimensions and manufacturing locations.

5.3 Hip & Ridge Shingles – 12-¼ X 12 Hip and Ridge, Heritage Vintage 12 X 12 Hip and Ridge, 12-¼ X 12 Heritage Hip and Ridge IR:

12-¼ X 12 Hip and Ridge, Heritage Vintage 12 X 12 Hip and Ridge, and 12-¼ x 12 Heritage Hip and Ridge IR shingles are prefabricated hip and ridge shingles. Heritage Vintage 12 X 12 Hip and Ridge shingles are perforated so they can be torn into three 12-inch by 12-inch shingles. The 12-¼ X 12 Hip and Ridge and 12-¼ X 12 Heritage Hip and Ridge IR shingles are perforated so they can be torn into three 12-¼ inch by 12-inch shingles. As an alternative, Elite Glass-Seal shingles are cut into three 12-¼ inch by 12-inch hip and ridge shingles. See [Table 8](#), [Table 9](#), and [Table 11](#) for product dimensions and manufacturing locations.

6. INSTALLATION

TAMKO asphalt shingles must be installed in accordance with the applicable code, this report and the manufacturer's published installation instructions. The shingles must be installed in accordance with [Section 1507.2](#) of the 2018, 2015, 2012, and 2009 IBC or [Section R905.2](#) of the 2018, 2015, 2012, and 2009 IRC, as applicable, except as noted in this report.

The manufacturer's published installation instructions must be available at all times on the jobsite during installation.

Minimum roof slopes must be 2:12 (16.67% slope) for the three-tab shingles described under 5.1 of this Report and for the laminated shingles described under 5.2 of this Report.

6.1 Underlayment and Ice Barriers:

For roof slopes greater than 4:12, the roof deck must be covered with a minimum of one layer of underlayment as described in Sections 7.2 and 7.3 of this Report. Underlayment application must be in accordance with [Table 1507.1.1\(2\)](#) of the 2018 IBC and [Section 1507.2.8](#) of the 2015, 2012, and 2009 IBC or [Section R905.2.7](#) of the 2018, 2015, 2012, and 2009 IRC, as applicable.

For roof slopes between 2:12 and 4:12, two layers of the underlayment described in Section 7.2 or one layer of the self-adhering polymer modified bitumen sheet in described in Section 7.3 of this Report are required. Underlayment application must be in accordance with [Table 1507.1.1\(2\)](#)

of the 2018 IBC and [Section 1507.2.8](#) of the 2015, 2012, and 2009 IBC or [Section R905.2.7](#) of the 2018, 2015, 2012, and 2009 of the IRC, as applicable.

In areas where there has been a history of ice forming along the eaves, causing a backup of water, an ice barrier must be provided in accordance with [Section 1507.1.2](#) of the 2018 IBC and [Section 1507.2.8.2](#) of the 2015, 2012, and 2009 IBC or [Section R905.2.7](#) of the 2018 IRC and [Section R905.16.4.1](#) 2015 IRC, and [Section R905.2.7.1](#) of the 2012, and 2009 IRC, as applicable.

6.2 Starter Shingle:

A starter course, as described in Section 7.4 of this Report, must be attached to the eave edge using fasteners described in Section 7.5 of this Report, located 1-½ to 3 inches (38.1 to 76.2 mm) from the eave edge and spaced 1 inch (25.4 mm) and 12 inches (305 mm) from each end, for a total of four fasteners per shingle. Starter strips must overhang the eave and rake edges ¼ to ¾ inch (6.4 to 19.1 mm) if no drip edge flashing is present. If drip edge flashing is present, install shingles even with the drip edge or overhang the drip edge up to ¾ inch.

6.3 Asphalt Shingles:

The first course of field shingles must be installed over the starter course described in Section 7.4 of this Report.

Shingles must be installed with vertical joints offset a minimum of 4 inches (102 mm) from adjacent courses.

6.3.1 Three-Tab Shingles – Elite Glass-Seal:

For roof slopes of 2:12 up to 21:12 (16.67% to 175% slope), each shingle must be fastened to the roof deck using a minimum of four fasteners, spaced as shown in Tables 2 and 3.

For roof slopes over 21:12 (175% slope), six fasteners must be used, spaced as shown in [Table 2](#).

Fasteners must be in a nail area between 5-⁵/₈ inches (143 mm) and 6-⁷/₈ inches (175 mm) from the butt edge of the shingle.

Maximum exposure to the weather must be 5-¹/₈ inches (130 mm).

In colder climates or wind regions where it is questionable whether the thermal-sealing adhesive will activate to seal the shingles, the shingles can be hand-sealed. A 1-in diameter (25.4 mm) spot of asphalt cement complying with ASTM D4586, Type I, Class I, should be placed under the corner of each tab (two spots per tab).

6.3.2 Laminated Shingles – Heritage, Heritage IR, Heritage Premium, Heritage Woodgate:

For roof slopes of 2:12 up to 21:12 (16.67% to 175% slope), each shingle must be fastened to the roof deck using a minimum of four fasteners, spaced as shown in Tables 3, 4, 5, 6 and 10.

For roof slopes over 21:12 (175% slope), six fasteners must be used, spaced as shown in Tables 3, 5, 6, and 10.

Fasteners must be located 6-¹/₈ inches (157 mm) above the butt edge of the shingles as shown in Tables 3, 5, 6, and 10. Fasteners must be located between 6-¹/₈ inches and 7-⁷/₈ inches from the butt edge of shingles as shown in Table 4.

Maximum exposure to the weather must be 5-⁵/₈ inches (143 mm).

In colder climates or wind regions where it is questionable whether the thermal-sealing adhesive will activate to seal the shingles, the shingles can be hand-sealed. Four evenly spaced 1-inch diameter (25.4 mm) spots of cement should be placed under the exposed portion of the shingle, approximately 1 inch (76 mm) above the butt edge.

6.3.3 Laminated Shingles – Heritage Vintage:

For roof slopes of 2:12 up to 21:12 (16.67% to 175% slope), each shingle must be fastened to the roof deck using a minimum of five fasteners, spaced as shown in Table 7.

For roof slopes over 21:12 (175% slope), nine fasteners must be used, spaced as shown in Table 7.

Fasteners must be located 6 and 11-¹/₂ inches (152 and 292 mm) above the butt edge of the shingles.

Maximum exposure to the weather must be 5 inches (127 mm).

In colder climates or wind regions where it is questionable whether the thermal-sealing adhesive will activate to seal the shingles, the shingles can be hand-sealed. Four evenly spaced 1-inch diameter (25.4 mm) spots of cement should be placed under the exposed portion of the shingle, approximately 1 inch (127 mm) above the butt edge.

6.4 Valley Construction and Other Flashing:

Valleys must consist of woven, open valley or closed-cut construction and must be flashed in accordance with [Section 1507.2.8.2](#) of the 2018 IBC and [Section 1507.2.9.2](#) of the 2015, 2012, and 2009 IBC or [Section R905.2.8.2](#) of the 2018, 2015, 2012, and 2009 IRC. Other flashings must be in accordance with [Sections 1503.2](#) and [1507.2.8](#) of 2018 IBC, [1507.2.9](#) of the 2015, 2012, and 2009 IBC, or [Section R903.2](#) and [Section R905.2.8](#) of the 2018, 2015, 2012, and 2009 IRC, as applicable.

6.5 Hip and Ridge Application:

Hip and ridge shingles must be placed evenly over hips and ridges, and must be fastened to the roof deck using two fasteners, one located on either side of the shingle, 5-¹/₂ inches (140 mm) or 5-⁵/₈ inches (143 mm) from the exposed end, and 1 inch (25.4 mm) from the edge as shown in Tables 8 and 9. Fasteners must be a minimum ¹/₄ inch (6.4 mm) longer than those used in the field of the roof, as specified in Section 7.5 of this report. The 12-¹/₄ X 12 Hip and Ridge and 12-¹/₄ x 12 Heritage Hip and Ridge IR prefabricated hip and ridge shingles must be installed with a maximum exposure of 5-¹/₈ in. (130 mm). Heritage Vintage 12 X 12 Hip and Ridge prefabricated hip and ridge shingles must be installed with a maximum exposure of 5 in. (127 mm). Hip and ridge shingles are installed starting at the bottom of the hip or from the end of the ridge opposite the direction of the prevailing wind.

6.6 Reroofing:

The existing asphalt shingle roof covering must be inspected in accordance with the provisions and limitations of [Section 1510](#) of the 2018, 2015, 2012, and 2009 IBC or [Section R907](#) of the 2018, 2015, 2012, and 2009 IRC, as applicable. Prior to the reroofing, hip and ridge coverings must be removed.

Except as noted in this section, the shingles must be installed in accordance with Section 6.3 and 6.5 of this Report. Fasteners must be of sufficient length to penetrate ³/₄ inch (19.1 mm) into the sheathing, or through the sheathing where the sheathing is less than ³/₄ inch (19.1 mm) thick. Flashing and edging must comply with Section 6.4 and with [Sections 1510.5](#) and [1510.6](#) of the

2018, 2015, 2012, and 2009 IBC and [Sections R907.5](#) and [R907.6](#) of the 2018, 2015, 2012, and 2009 IRC, as applicable.

7. INSTALLATION MATERIALS

7.1 Sheathing:

The roof deck must be code-complying, minimum $\frac{3}{8}$ -inch thick (9.5 mm), exterior plywood complying with DOC PS-1; rated sheathing complying with DOC PS-2; or solid sheathing using minimum nominally 1 by 6 lumber.

7.2 Underlayment:

Under the IBC or IRC, underlayment must comply with ASTM D226, Type I (minimum), ASTM D4869, Type I (minimum) or ASTM D6757 as specified in [Section 1507.2.3](#) of the 2018, 2015, 2012, and 2009 IBC or [Section R905.2.3](#) of the 2018, 2015, 2012, and 2009 IRC.

7.3 Self-adhering Polymer Modified Bitumen Sheet:

The self-adhering polymer modified bitumen sheet must comply with ASTM D1970.

7.4 Starter Shingles:

The starter course shingle consists of either TAMKO 10-inch starter, TAMKO Shingle Starter, TAMKO Perforated Starter, or a self-sealing three-tab shingle. If self-sealing three-tab shingles are used, remove the exposed tab portion and install with factory-applied sealant adjacent to the eaves.

Heritage Vintage requires a Heritage Vintage starter to be installed over the first starter course at the eave edge.

7.5 Fasteners:

Fasteners must be minimum No. 12 gage [0.105 inch (2.7 mm)], $\frac{3}{8}$ -inch diameter head (9.5 mm), galvanized, stainless steel, aluminum or copper corrosion-resistance nails. Fasteners must be of sufficient length to penetrate into the sheathing $\frac{3}{4}$ -inch (19.1 mm), or through the sheathing, where the sheathing is less than $\frac{3}{4}$ -inch (19.1 mm) thick. Fasteners must be compliant with ASTM F1667.

7.6 Asphalt Cement:

Asphalt cement must comply with ASTM D 4586, Type I, Class I.

8. CONDITIONS OF USE

The TAMKO Asphalt Shingles described in this Report comply with, or are suitable alternatives to, what is specified in those codes listed in Section 2 of this Report, subject to the following conditions:

- 8.1 Materials and methods of installation shall comply with this Report and the manufacturer's published installation instructions. In the event of a conflict between the installation instructions and this Report, this Report governs.
- 8.2 The products are manufactured at the locations listed in [Table 1](#) of this Report under the UL LLC Classification and Follow-Up Service Program, which includes regular audits in accordance with quality elements of ICC-ES Acceptance Criteria for Quality Documentation, AC10.
- 8.3 See UL [Product iQ™ database](#) for Prepared Roof-Covering Materials (TFWZ).

9. SUPPORTING EVIDENCE

- 9.1 Manufacturer's descriptive product literature, including installation instructions.
- 9.2 See UL [Product iQ™ database](#) for the following:
- 9.2.1 UL test reports and Classification in accordance with ANSI/UL 790, Class A and UL Subject 2375 for Roof-Covering Materials ([TFWZ](#)).
 - 9.2.2 UL test reports and Classification in accordance with ICC ES Acceptance Criteria for Alternative Asphalt Roofing Shingles, AC438. ([TFWZ](#)).
 - 9.2.3 UL test reports and Classification in accordance with ASTM D7158, Class H for Prepared Roof-Covering Materials ([TGAH](#)).
 - 9.2.4 UL test reports and Classification in accordance with ASTM D3161, Class F Prepared Roof-Covering Materials ([TFWZ](#)).
- 9.3 Quality Documentation in accordance with ICC-ES Acceptance Criteria for Quality Documentation, AC10.

10. IDENTIFICATION

TAMKO asphalt shingles described in this Evaluation Report are identified by a marking on each package bearing the report holder's name (TAMKO Building Products LLC), the plant identification, the product name, the UL Listing/Classification Mark and the evaluation report number UL ER2919-02. The validity of this Evaluation Report is contingent upon this identification appearing on the package.

11. USE OF UL EVALUATION REPORT

- 11.1 The approval of building products, materials or systems is under the responsibility of the applicable authorities having jurisdiction.
- 11.2 UL Evaluation Reports shall not be used in any manner that implies an endorsement of the product, material or system by UL.
- 11.3 The status of this report, as well as a complete directory of UL Evaluation Reports may be found at UL.com via the [Product iQ™ database](#).

Table 1 – Manufacturing Locations

LISTEE	LOCATION	FACTORY ID
TAMKO BUILDING PRODUCTS LLC	7910 S CENTRAL EXPY DALLAS TX 75216	D
TAMKO BUILDING PRODUCTS LLC	4500 TAMKO DR FREDERICK MD 21704	F
TAMKO BUILDING PRODUCTS LLC	601 N HIGH ST JOPLIN MO 64801	J
TAMKO BUILDING PRODUCTS LLC	1598 HWY 183 PHILLIPSBURG KS 67661	P
TAMKO BUILDING PRODUCTS LLC	KAUL INDUSTRIAL PARK 2300 35TH ST TUSCALOOSA AL 35401	T

Table 2 – Elite Glass-Seal

Dimensions:	12- $\frac{1}{4}$ " x 36"
Plant Location(s):	Frederick, Joplin, Tuscaloosa
Fastening Pattern:	For slopes of 2:12 up to 21:12 
Fastening Pattern:	For slopes greater than 21:12 

Table 3 – Heritage

Dimensions:	13-1/4" x 39-3/8"
Plant Location(s):	Dallas, Frederick, Joplin, Phillipsburg
Fastening Pattern:	<p>For slopes of 2:12 up to 21:12</p>
Fastening Pattern:	<p>For slopes greater than 21:12</p>

Table 4 – Heritage

Dimensions:	13-1/4" x 39-3/8"
Plant Location(s):	Tuscaloosa
Fastening Pattern:	<p>For slopes of 2:12 up to 21:12</p> <p>Diagram illustrating preferred fastener locations and acceptable fastener locations relative to the edge of the common bond and the paint line. The diagram shows a cross-section of the roof edge with a 7-7/8" height. A horizontal line represents the fastener line, with a 1" gap from the left edge to the first fastener and a 1" gap from the last fastener to the right edge. The right edge has an exposure of 5-5/8". A 'PAINT LINE' is shown above the fastener line. Labels include 'PREFERRED FASTENER LOCATIONS', 'NAIL ZONE', 'EDGE OF COMMON BOND', 'EXPOSURE 5-5/8"', 'ACCEPTABLE FASTENER LOCATION', and 'DO NOT FASTEN ALONG EDGE OF COMMON BOND'. A circular inset shows a close-up of a fastener location, with a 'PREFERRED FASTENER LOCATION' indicated by a dot and an 'ACCEPTABLE FASTENER LOCATION' indicated by a larger shaded area.</p>

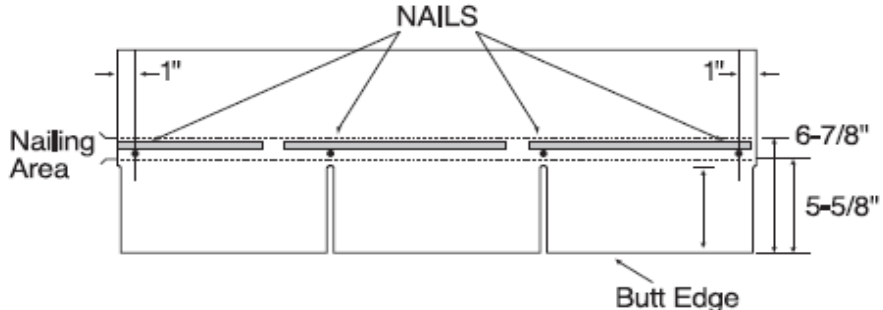
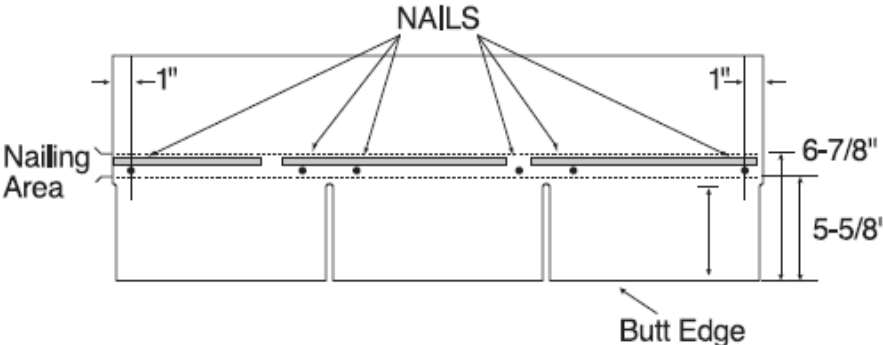
Table 5 – Heritage Premium

Dimensions:	13-1/4" x 39-3/8"
Plant Location(s):	Phillipsburg, Frederick
Fastening Pattern:	<p>For slopes of 2:12 up to 21:12</p>
Fastening Pattern:	<p>For slopes greater than 21:12</p>

Table 6 – Heritage Woodgate

Dimensions:	13-1/4" x 39-3/8"
Plant Location(s):	Dallas, Frederick
Fastening Pattern:	<p>For slopes of 2:12 up to 21:12</p>
Fastening Pattern:	<p>For slopes greater than 21:12</p>

Table 7 – Heritage Vintage

<p>Dimensions:</p>	<p>17-1/2" x 40"</p>
<p>Plant Location(s):</p>	<p>Phillipsburg</p>
<p>Fastening Pattern:</p>	<p>For slopes of 2:12 up to 21:12</p>
<p>Fastening Pattern:</p>	<p>For slopes greater than 21:12</p> <p>Apply under each tab 1" diameter asphalt adhesive cement.</p>

Table 8 – Heritage Vintage 12 X 12 Hip and Ridge

Dimensions:	12" x 12"
Plant Location(s):	Phillipsburg
Fastening Pattern:	<p>The diagram illustrates the fastening pattern for a 12" x 12" hip and ridge. It shows a square with a horizontal line across the top. Two dots representing nails are located on this line, each 1 inch from the left and right edges. A vertical dimension of 5 inches is shown from the bottom edge to the top line, labeled "5" Exposure". A vertical dimension of 5 1/2 inches is shown from the bottom edge to the horizontal line. The total width of the square is 12 inches.</p>

Table 9 – 12-¼ X 12 Hip and Ridge

Dimensions:	12-¼" x 12"
Plant Location(s):	Frederick, Joplin
Fastening Pattern:	 <p>The diagram illustrates the fastening pattern for a 12-¼" x 12" hip and ridge. It shows a rectangular area with a height of 12-¼" and a width of 12". A horizontal line representing the ridge is positioned 5 5/8" from the bottom edge. Two nails are shown on this ridge, each 1" from the left and right edges. The distance from the bottom edge to the top of the ridge is labeled as 5 1/8" Exposure.</p>

Table 10 – Heritage IR

<p>Dimensions:</p>	<p>13-1/4" x 39-3/8"</p>
<p>Plant Location(s):</p>	<p>Joplin, Philipsburg</p>
<p>Fastening Pattern:</p>	<p>For slopes of 2:12 up to 21:12</p> 
<p>Fastening Pattern:</p>	<p>For slopes greater than 21:12</p> 

Table 11 Heritage Hip and Ridge IR

Dimensions:	<p>12-³/₄" x 12"</p>
Plant Location(s):	<p>Joplin</p>
Fastening Pattern:	

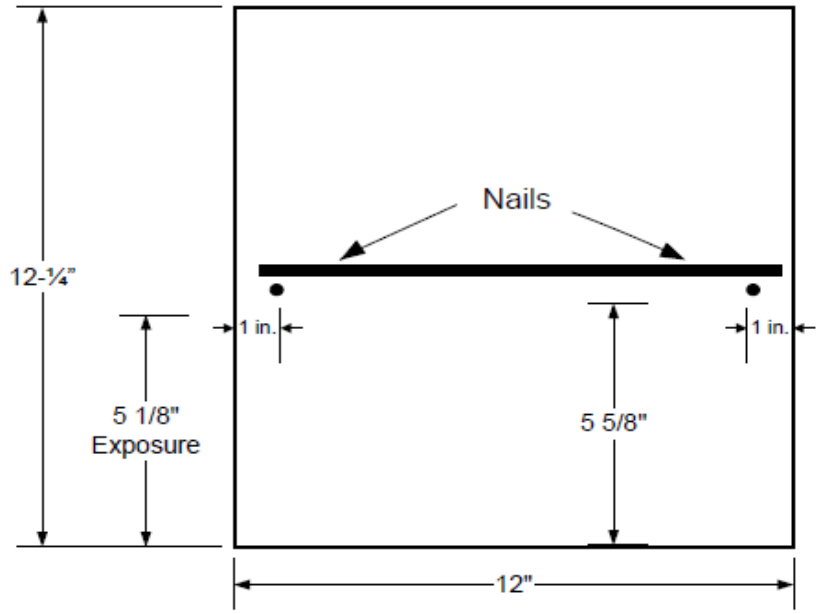
© 2019 UL LLC

This UL Evaluation Report is not an endorsement or recommendation for use of the subject and/or product described herein. This report is not the UL Listing or UL Classification Report that covers the subject product. The subject product's UL Listing or UL Classification is covered under a separate UL Report. UL disclaims all representations and warranties whether express or implied, with respect to this report and the subject or product described herein. Contents of this report may be based on data that has been generated by laboratories other than UL that are accredited as complying with ISO/IEC Standard 17025 by the International Accreditation Service (IAS) or by any other accreditation body that is a signatory to the International Laboratory Accreditation Cooperation (ILAC) Mutual Recognition Arrangement (MRA). The scope of the laboratory's accreditation shall include the specific type of testing covered in the test report. As the accuracy of any non-UL data is the responsibility of the accredited laboratory, UL does not accept responsibility for the accuracy of this data.

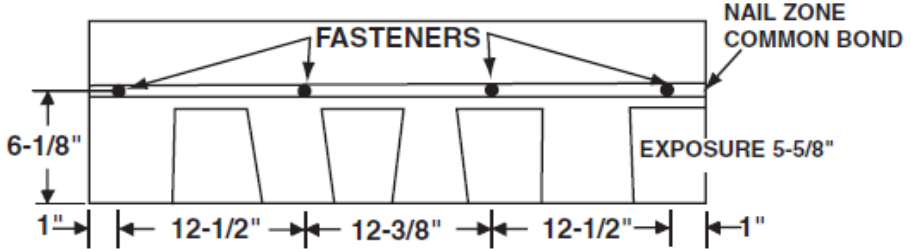
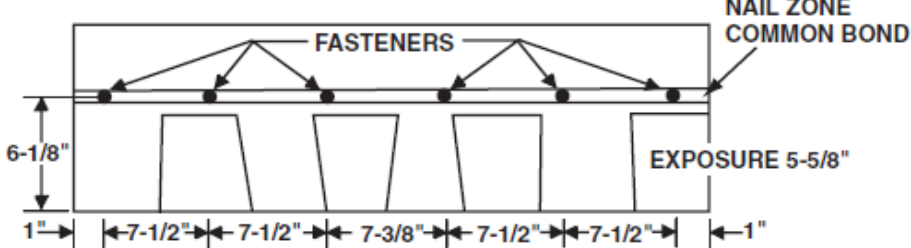