

---

## 1. Approved Detailing Components

- 1.1 Dymonic® 100 (green) – A high-performance, medium-modulus, low-VOC, UV stable, non-sag polyurethane sealant that can be used for detailing fasteners, board joints, around penetrations, as angle beads in transition areas, in control/expansion joints with break metal, for terminating ExoAir® 110AT, and under all the Vulkem Coating Systems and TREMproof Waterproofing membranes.
- 1.2 Spectrem® 1 (purple) – An ultra-low modulus, high-performance, one-part moisture curing silicone joint sealant used to adhere Proglaze ETA Connections to the Securock® ExoAir® 430 Panel. Spectrem 1 should never be used underneath any membrane or sealant unless adhesion has been verified.
- 1.3 Proglaze® ETA Connections – A pre-engineered silicone material used as a transition membrane for expansion joints between the Securock ExoAir 430 Panels. It is comprised of a flat singled ribbed silicone extrusion that is adhered to the panel with Spectrem 1 (purple) silicone sealant.
- 1.4 Dymonic® Simple Seal - A pre-engineered polyurethane material used as a transition membrane for expansion joints between the Securock ExoAir 430 Panels. It is a polyurethane extrusion that is adhered to the panel with Dymonic 100 (green) polyurethane sealant.
- 1.5 ExoAir® 110AT – A 22-mil composite impermeable membrane that is comprised of 16 mils of butyl and 6 mils of HDPP facer. It can be used as the membrane or as a detailing accessory of an air barrier system. ExoAir 110AT when installed properly as a system will provide the requirements of an air barrier: air impermeable, continuity, structural integrity and durability.
- 1.6 Securock® ExoAir® Reinforcing Mesh – A mesh that is fully embedded in ExoAir 230 in light orange for transition areas.
- 1.7 ExoAir® 230 (light orange) – A fluid-applied, synthetic, vapor-permeable air barrier designed for use in commercial construction applications. It can be sprayed, rolled or trowel-applied to common substrates. ExoAir 230 can be used as an air barrier membrane on adjacent substrates such as concrete or CMU, and can also be used in conjunction with Securock ExoAir Reinforcing Mesh as a transition material.

---

## 2. Additional Tremco Materials

- 2.1 TREMDrain – Drainage is incorporated to enhance the performance of the overall waterproofing system and reduce the amount of hydrostatic pressure. It is represented in the below-grade detail with TREMproof Waterproofing.
- 2.2 TREMproof Waterproofing – System of products used to effectively keep the water out of a structure. The water-proofing system can provide the protection, durability and continuity required.
- 2.3 Vulkem Coating Systems – System of high-performance concrete coatings to extend the longevity of concrete structures.
- 2.4 Tremco® Epoxy Primer – Tremco Epoxy Primer is a two-component (1:1) primer used as a compatible tie-in to create connectivity between the Securock ExoAir Panel and the TREMproof below-grade waterproofing membranes or Vulkem urethane coatings.
- 2.5 ExoAirLEF – A single-component, moisture-curing, gun-grade polyurethane foam that is used to insulate and act as a bond breaker around penetrations.
- 2.6 TREMprime® BE Primer – A VOC-compliant adhesive formulated to promote adhesion to the exposed gypsum core of the exterior sheathing prior to the application of sealant or flashing.
- 2.7 The above Tremco materials can be purchased through local Tremco distribution. Please contact us at 800.321.7906.

---

### 3. General

- 3.1 The purpose of this document is to establish uniform procedures for installing Securock ExoAir 430.
- 3.2 The techniques involved may require modifications to adjust to jobsite conditions. Tremco recognizes that site specific conditions, weather patterns, contractor preferences and membrane detailing may require deviation or alteration from these prescribed installation procedures. When such circumstances exist on a project, Tremco recommends that the local Tremco Sales Representative or Tremco Technical Service be contacted for assistance and approval as required.
- 3.3 This panel shall be installed in accordance with GA-253 Application of Gypsum Sheathing, ASTM C1280 Standard Specification for Application of Exterior Gypsum Panel Products for Use as Sheathing and the requirements of USG and Tremco published literature.
- 3.4 The Securock Exoair 430 system has a 12-month UV exposure limit. However, the proper detailing of joints must be completed as soon as possible. At a minimum, detailing of the joints must be completed either before exterior cladding is installed or 6 months after the date of installation of the panels, whichever comes first. If the time to complete the detailing needs to be extended beyond this deadline, the local Tremco Sales Representative must be contacted for assistance and approval based on the circumstances surrounding the project as required. Without such approval, these application instructions will be deemed to not have been followed.
- 3.5 Roofing systems shall be capped and sealed, or top of walls protected, in such a way as to eliminate the ability of water to saturate the wall or interior space, both before and after, air barrier system installation. Coordinate installation of Securock ExoAir 430 System with the roofing trade to ensure compatibility and continuity with the roofing system.
- 3.6 A pre-construction meeting with all parties involved in the overall building envelope shall be held prior to any installation activities. This meeting is crucial and will ensure that installation sequencing, system connectivity and product compatibility are properly addressed.
- 3.7 The system is comprised of the Securock ExoAir 430 Panel and system components, such as Dymonic 100 (green), Spectrem 1 (purple) sealant, Proglaze ETA connections and ExoAir 110AT. Please see the complete list of approved detailing components in Section 1 for product selection.
- 3.8 Ensure substrates are clean, dry and free of dust or debris that could prevent adhesion of sealant.
- 3.9 This product is not approved for use as a nail base.
- 3.10 Details and requirements pertaining to framing and application limitations shall be controlled by the cladding, structural or fire-resistant-rated system, and must be approved by the design professional of record.
- 3.11 A job standard or mock-up should be designed and built on-site for reference during pre-construction meetings and during installation operations. The Standard should be constructed using the same materials, techniques and sequencing expected on the project to establish a definitive expectation of the final system.
- 3.12 Details for construction for a specific assembly to achieve a required fire resistance shall be obtained from reports of fire resistance tests, engineering evaluations or listings from recognized fire-resistance laboratories.
- 3.13 Where sound control is required, details of construction shall be in accordance with an acoustical test report of an assembly that has met the required acoustical value(s).
- 3.14 Details of construction shall be in accordance with test report(s) of an assembly that has met required air and water barrier performance criteria.
- 3.15 Where resistance to racking shear and/or transverse wind load is required, system design capacities shall be obtained from USG published literature, engineering evaluations and test reports of a specific assembly where mandated by local code requirements.
- 3.16 Manage sequence of installation of the Securock ExoAir 430 Panel and detailing components with other trades and systems to ensure continuity and compatibility. Once the building is enclosed, by whatever means, care should be taken to prevent excess moisture/humidity buildup on the interior side of the Securock ExoAir Panel. Avoid conditions during construction that result in excessive moisture load in the building. High moisture can cause condensation in the unfinished exterior walls and sheathing during periods of cold weather. Forced air heaters, wet masonry, poured concrete and finishing materials introduce large volumes of water vapor into the building. Use ventilation and mechanical dehumidification to reduce moisture levels to below the dew point temperature of the exterior air. Any damage resulting from insufficient interior moisture management during construction is not the responsibility of USG. At

every point in the construction process, minimizing moisture exposure is the key to maximizing the performance of the finished assembly. Refer to Gypsum Association ([www.gypsum.org](http://www.gypsum.org)) for information.

- 3.17 System components require that the panel be clean, dry and sound before installation. Connect the panel to adjacent parts of the building envelope such as the roof membrane, below-grade wall, window and curtain wall systems, and other parts of the building envelope.
- 3.18 The techniques involved may require modifications to accommodate jobsite conditions. USG and Tremco recognize that site-specific conditions, weather patterns, contractor preferences and membrane detailing may require deviation or alteration from these prescribed installation procedures. When such circumstances exist on a project, the local Sales Representative or Technical Services must be contacted for assistance and approval as required.
- 3.19 This document provides the basic and typical instructions for the installation of Securock ExoAir 430 System to qualify for the Securock ExoAir 430 Warranty. Jobsite-specific details require the review and approval of a local Sales Representative or Technical Services.
- 3.20 Always wear appropriate personal protective equipment when handling and installing glass mat panels, such as gloves, safety glasses, hearing protection and a NIOSH-approved dust mask.

---

## 4. Delivery and Job Site Storage

- 4.1 All materials shall be delivered in their original unopened packages and stored in an enclosed shelter providing protection from damage and exposure to the elements.

---

## 5. Framing

- 5.1 Securock ExoAir 430 Panel shall be installed on either wood or steel framing. The framing system shall be sized and designed to meet the requirements of the intended application.
- 5.2 The maximum spacing for framing members is 24" o.c.
- 5.3 Framing shall be straight and true, attached securely following accepted engineering practices and as required for the intended design.
- 5.4 The surfaces to which abutting edges or ends of the panels are to be attached shall not be less than 1¼" for steel framing, and 1½" for wood framing.
- 5.5 Bearing surfaces shall not be less than 5/8" for internal corners or angles.
- 5.6 Framing members shall be installed so the surface will be in an even plane, unless otherwise specified, after the panel(s) has been applied. The fastening surface shall not vary more than 1/8" from the plane of the faces of adjacent framing members.
- 5.7 If wood blocking is desired in steel stud construction for setting windows, doors, etc., position dimensional lumber flush with exterior surface of steel stud and mechanically anchor every 12" o.c. Minimum dimensional size of wood blocking to be nominal 2x4 lumber.

---

## 6. Panel Cutting and Applications

- 6.1 Securock ExoAir 430 Panel may be applied with long dimensions parallel or perpendicular to framing members, orange side to exterior. Panel orientation may be governed by local code, or by the requirements of shear or fire-rated construction. Consult local codes and site-specific construction documents prior to construction to ensure such requirements are met for every assembly.
- 6.2 Securock ExoAir 430 Panel shall be cut to size by scoring the panel face with a utility knife, or by sawing. Separate by snapping the panel away from the score line to fracture the core, and then by scoring the back mat with a utility knife. If a power saw is used, a cordless, low rpm saw will generate less airborne debris than a corded power saw.
- 6.3 The cut edges and ends of the panel shall be trimmed to obtain neat-fitting joints and flush with framing edges in rough opening if panel is used in rough opening.
- 6.4 Holes for pipe penetrations, fixtures or other small openings shall be scored on the orange face side before removing the cutout with a saw or special tool designed for this purpose.

- 6.5 Where Securock ExoAir 430 Panels meet projecting surfaces, the panel shall be scribed and cut neatly.
- 6.6 All vertical ends and edge joints shall abut over the centers of framing members and shall be offset a minimum of one framing bay between adjacent rows of panels.
- 6.7 Panel joints shall be offset a minimum of 4" from the edge of any opening.
- 6.8 Panels shall be detailed at openings to prevent any water intrusion beyond the membrane of the panel.
- 6.9 Center panel joints on framing members. Fit panels closely at edges and ends but do not force the panels together. Gaps between boards shall not exceed 1/8". Gaps greater than 1/8" but less than 1/2" shall be filled with Dymonic 100 (green) as fill material prior to detailing board joint as seen in section 8. If gap exceeds 1/2", panel must be repositioned or repaired per repair instructions listed in section 22.
- 6.10 Hold panels in firm contact with framing members and secure with fasteners as specified.
- 6.11 Fasteners shall be driven so the head is seated flush to the membrane of the panel surface without breaking or punching through the surface. Wafer or modified truss head fasteners shall be driven so the underside of the head is flush against the panel surface without breaking or punching through the surface.
- 6.12 Fasteners shall be driven without stripping the fastener or the framing member around the screw shank. Should a fastener miss or strip out of the framing member, DO NOT remove the fastener; an additional fastener shall be properly installed minimum 1" and maximum 2" from damaged area.
- 6.13 Fasteners shall be located not less than 3/8" and not more than 1" from the ends and edges of the panel and shall be placed 8" maximum o.c.
- 6.14 Fasteners can be either bugle or wafer head.
- 6.15 All fastener heads shall be detailed after installation with minimum 1/16" thickness (60 mils) and 3/4" minimum diameter quantity of Dymonic 100 (green) sealant.
- 6.16 Unless superseded by a more stringent specification, the minimum requirements for panel fasteners shall be as follows:
- 6.17 FASTENER SPECIFICATION
- 6.18 Screws- (1-1/4") (1-5/8") #6 bugle head corrosion resistant fasteners equal to or greater than 48 hours in accordance with ASTM B117.
- 6.19 Supplementary use of a panel adhesive to adhere the panel to the framing will strengthen the connection and bridge minor irregularities between the panel and the framing. The use of an adhesive, however, will not reduce the number of fasteners required by the specification. For optimal bond, apply adhesive in accordance with the adhesive manufacturer's instructions. Care should be taken so excess adhesive does not contaminate board joints. Framing must be free from oil and dirt, and panel must be clean and dry.

---

## 7. Soffit Construction

- 7.1 The roof must be dried in prior to horizontal installation of panels in all soffit applications.
- 7.2 Maximum fastener spacing for soffits is 8" o.c.

---

## 8. Board Joints

### 1. IN PLANE BOARD JOINTS - DETAIL 12969

---

- 1.1 Ensure board joints are in compliance with section 6.9
- 1.2 For in plane board joints apply and tool Dymonic 100 (green) sealant ensuring minimum overlap of 3/4" onto each panel at a 1/16" (60 mils) thickness.
- 1.3 For intersections of vertical and horizontal board joints, caution should be taken to not remove or disturb existing sealant when overlapping.
- 1.4 Feather sealant on horizontal joints out onto panel.

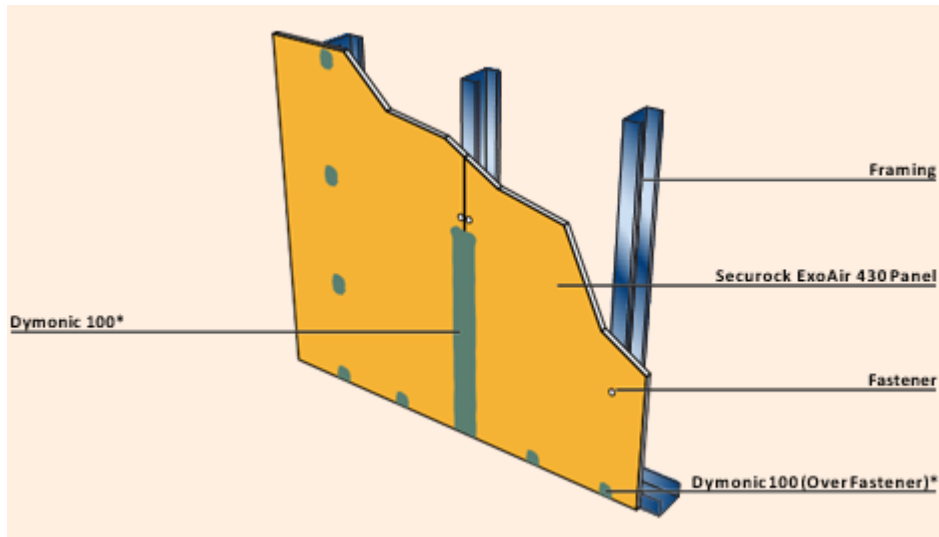

1.5 \*Spectrem 1 is an alternative to Dymonic 100, but cannot be used with an adhesively-applied cladding.

## 9. Corners

### 1. INSIDE CORNERS - DETAIL 12885

- 1.1 Ensure boards joints are in compliance with section 6.9.
- 1.2 Install minimum 1/2" wide bond breaker tape centered on joint.
- 1.3 Apply 1/2" bead of Dymonic 100 (green) sealant bead over bond breaker tape.
- 1.4 Tool to achieve cove bead, minimum 1/4" bond beyond edge of bond breaker tape to panel surface on each side of joint.

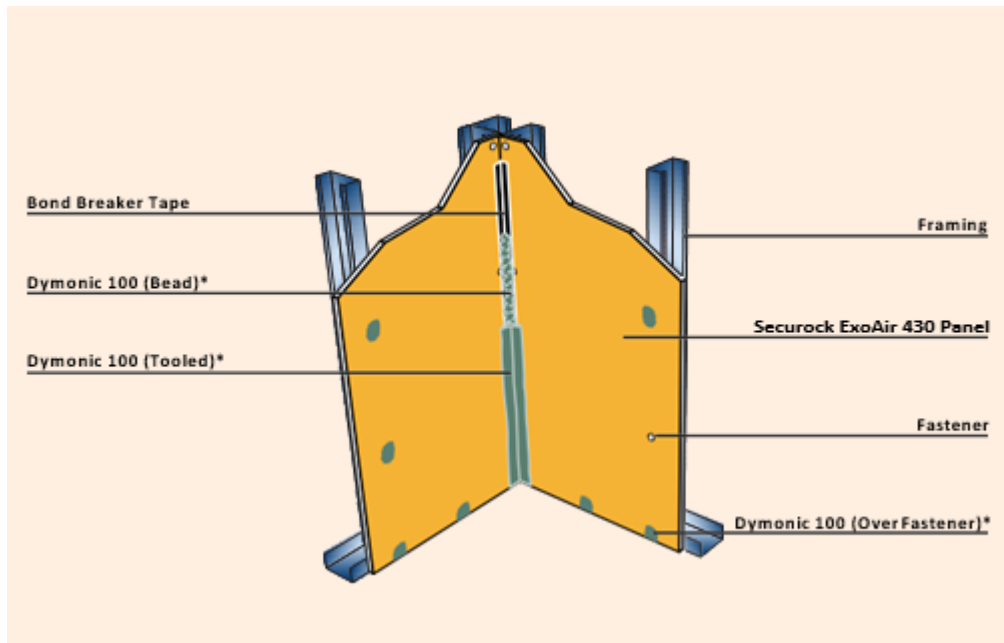

1.5 \*Spectrem 1 is an alternative to Dymonic 100, but cannot be used with an adhesively-applied cladding.

### 2. OUTSIDE CORNERS – DYMONIC 100 SEALANT - DETAIL 14115

- 2.1 Ensure boards joint are in compliance with section 6.9

- 2.2 Apply a continuous bead of Dymonic 100 (green) sealant in a zigzag pattern or a straight bead on each side of the joint. Tool Dymonic 100 sealant over the corner joint so that sealant grips the Securock ExoAir 430 membrane a minimum of 1" on both sides. Ensure there are no holes or gaps in the sealant and feather it on both sides. Using a mil gauge, ensure that a minimum of 40 wet mils have been applied; if not, reapply sealant to achieve 40 wet mils.

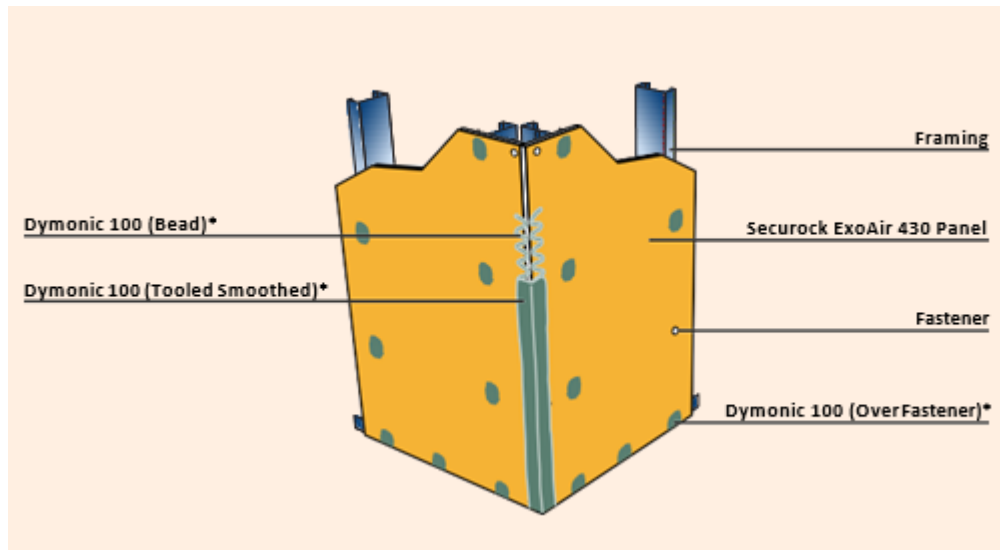

- 2.3 *\*Spectrem 1 is an alternative to Dymonic 100, but cannot be used with an adhesively-applied cladding.*

### 3. OUTSIDE CORNERS – SELF-ADHERED MEMBRANE - DETAIL 15838

- 3.1 Ensure boards joint are in compliance with section 6.9
- 3.2 Apply the ExoAir 110AT to the outside corner centered with a minimum 3" on each side of the corner. Once positioned properly, remove the backing and smooth and press firmly into place. Mechanically roll to smooth out any fish mouths or air pockets in the membrane.
- 3.3 ExoAir 110AT can be applied vertically or horizontally. ExoAir 110AT membrane shall be lapped onto previous sheet a minimum of 2" (5 cm) when overlap is in plane. All other transitions should have a minimum of 3" (8 cm) overlap. All horizontal laps should be shingled. ExoAir 110AT must be mechanically roll pressed with a J-Roller to ensure the ExoAir 110AT develops sound contact to the substrate.
- 3.4 Terminate with Dymonic 100 (green) on any horizontal edge not oriented to shed water or at the end of the day's work.

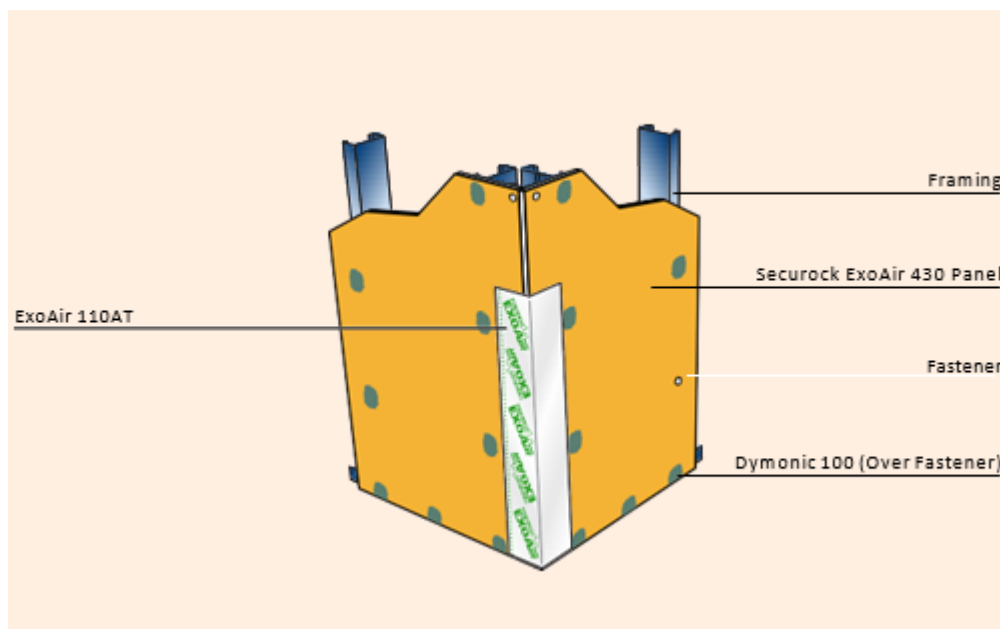

---

## 10. Expansion / Control Joints

- 10.1 The design and placement of control joints is the responsibility of the design professional of record.
- 10.2 Locate all control joints as per cladding system requirements, or in accordance with ASTM C1280 Standard Specification for Application of Gypsum Panel Products for Use as Sheathing, whichever is more stringent.

---

### 1. EXPANSION / CONTROL JOINTS - PROGLAZE ETA CONNECTIONS - DETAIL 12888

---

- 1.1 Friction fit closed cell backer rod flush with the surface of the Securock ExoAir 430 Panel.
- 1.2 Bonding of Proglaze ETA component is achieved with continuous and interconnecting bedding beads of Spectrem 1 (purple) silicone sealant. Apply Spectrem 1 (purple) to the edges of the Securock ExoAir 430 Panel Provide 1" wide continuous bedding along edges of the Proglaze ETA adhered to the Securock ExoAir 430 Panel membrane surface and within overlaps of lineals of the Proglaze ETA. Assure that Proglaze ETA is centered over gap and sufficient sealant is applied to achieve the 1" bedding bead. Using a hand-held seam roller, lightly roll press the Proglaze ETA to firmly bed, rolling toward its edge to force some sealant out, creating a slight bleed, and then tool the excess sealant back over the top of the Proglaze ETA.
- 1.3 Preplan installation to minimize splicing of Proglaze ETA. When splicing is required, provide a minimum 1" overlap of the Proglaze ETA. Installation should begin at bottom of joint following typical construction practices of proper shingle effect of the overlap for vertical joints. For horizontal joints connected to vertical control joints, horizontal joint shall be detailed first then lapping vertical joint over top.

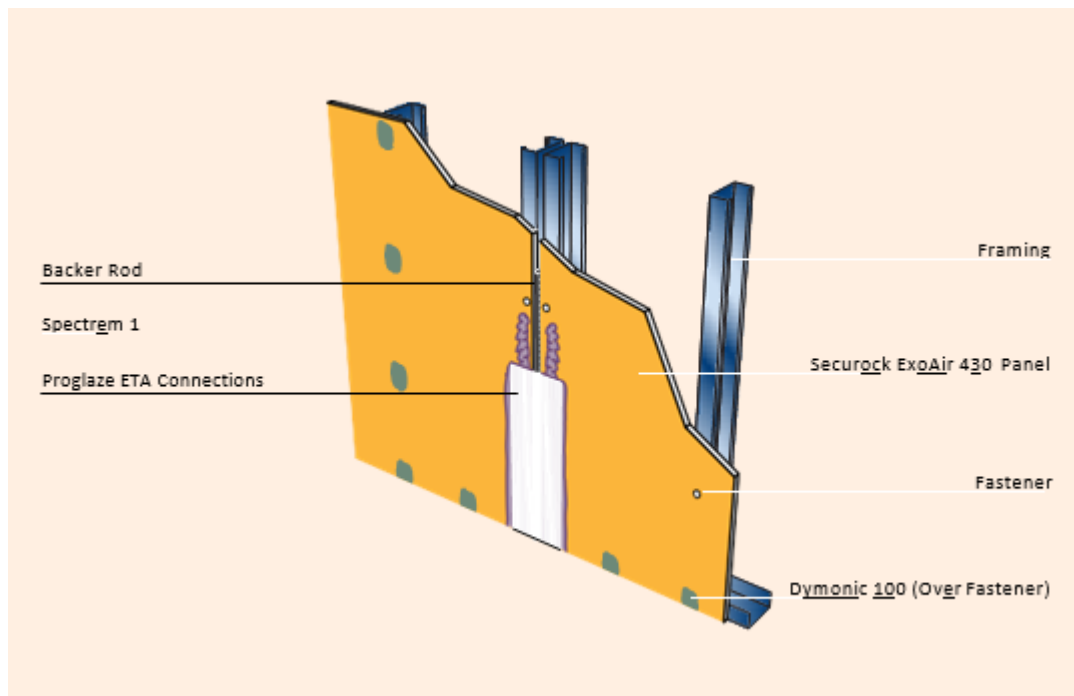

---

### 2. EXPANSION / CONTROL JOINTS - DYMONIC SIMPLE SEAL - DETAIL 19321

---

- 2.1 Friction fit closed cell backer rod flush with the surface of the Securock ExoAir 430 Panel.
- 2.2 Bonding of Dymonic Simple Seal is achieved with continuous and interconnecting bedding beads of Dymonic 100 (green) sealant. Apply Dymonic 100 (green) to the edges of the Securock ExoAir 430 Panel. Provide 1" wide continuous bedding along edges of Dymonic Simple Seal adhered to the Securock ExoAir 430 Panel membrane surface and within overlaps of lineals of the Dymonic Simple Seal. Assure that Dymonic Simple Seal is centered over gap and sufficient sealant is applied to achieve the 1" bedding bead. Using a hand-held seam roller, lightly roll press the Dymonic Simple Seal to firmly bed, rolling toward its edge to force some sealant out, creating a slight bleed, and then tool the excess sealant back over the top of the Dymonic Simple Seal.

- 2.3 Preplan installation to minimize splicing of Dymonic Simple Seal. When splicing is required, provide a minimum 1" overlap of the Dymonic Simple Seal. Installation should begin at bottom of joint following typical construction practices of proper shingle effect of the overlap for vertical joints. For horizontal joints connected to vertical control joints, horizontal joints shall be detailed first then lapping vertical joint over top.

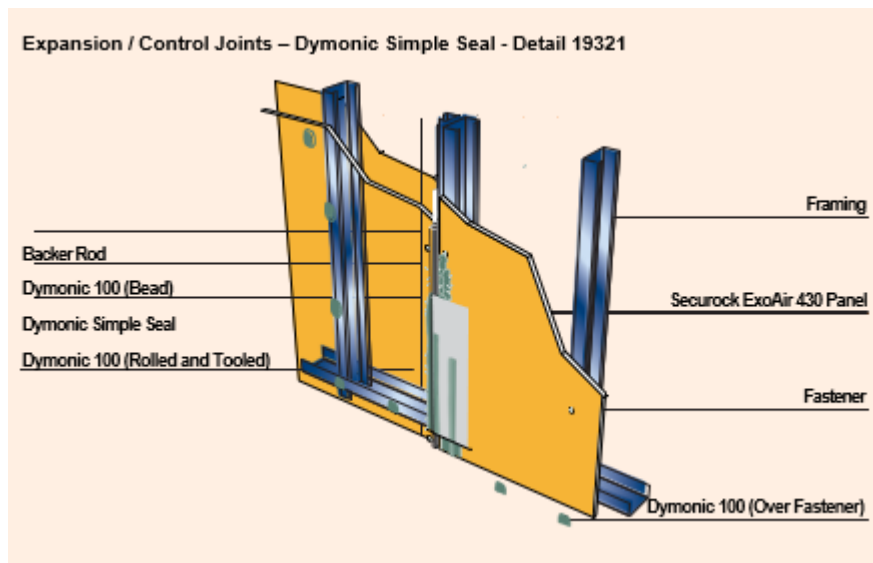

- 2.4 *\*Spectrem 1 is an alternative to Dymonic 100, but cannot be used with an adhesively-applied cladding.*

## 11. Penetrations

### 1. NON-RATED WALL PENETRATIONS - DETAIL 12887

- 1.1 This section is intended to provide guidance for preparing the rough opening for penetrations.
- 1.2 The minimum annular space can be 0", (point contact) to maximum 1/2".
- 1.3 For annular spaces exceeding 0" up to 1/4", apply a code bead of Dymonic 100 (green) sealant maintaining a minimum 1/4" bond to both the membrane surface and the penetration.
- 1.4 For annular spaces exceeding 1/4" up to 1/2", fill any gaps with closed cell backer rod flush with the membrane surface of the panel. A code bead of Dymonic 100 (green) sealant shall be installed that will maintain a minimum 1/4" bond to both the membrane surface and the penetration.
- 1.5 For annular spaces larger than 1/2" please contact the local Sales Representative or USG/Tremco Technical Services.
- 1.6 If detail work is being done, seal around brick-ties and other penetrations with Dymonic 100, ExoAir Termination Mastic or Spectrem 1. Spectrem 1 may be used when there will not be any additional ExoAir membranes installed over it. Location, cladding type and service life temperature may determine which detail material must be used.
- 1.7 Tremco has conducted in-house testing on a variety of fasteners used in commercial construction for attaching various insulation/cladding systems. The results demonstrated that if installed properly according to the manufacturer's installation instructions, the fasteners/façade anchors tested in conjunction with the ExoAir membranes created an air and watertight seal. Tremco recommends contacting Technical Service at [www.tremcosealants.com](http://www.tremcosealants.com) for a list of evaluated fasteners/façade anchors, or to submit a fastener/ façade anchor for testing

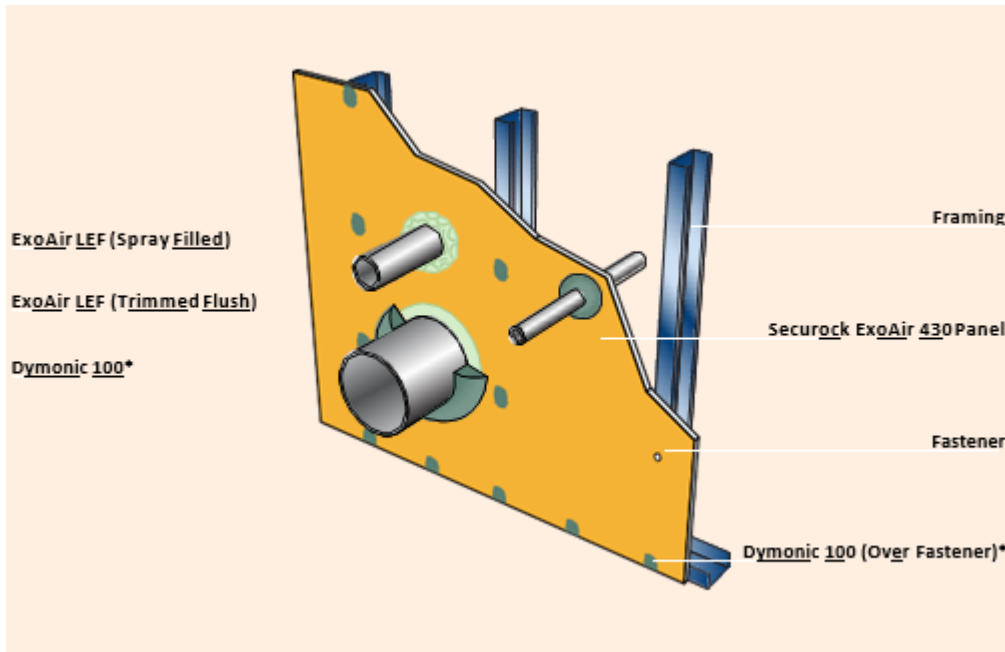

1.8 \*Spectrem 1 is an alternative to Dymonic 100, but cannot be used with an adhesively-applied cladding.

## 12. Rough Openings

12.1 This section is intended to provide guidance for preparing the rough opening for fenestrations. Consult fenestration manufacturer's installation instructions for specific installation practices.

### 1. ROUGH OPENINGS – DYMONIC 100 SEALANT - DETAIL 14135, 14113, 15839

1.1 Apply a continuous bead of Dymonic 100 (green) sealant in all four corners of the rough opening where the sill, jamb and head meet. Apply a continuous bead of Dymonic 100 (green) sealant in a zigzag pattern or a straight bead around the face of the panel, the sill, jambs and head. Tool Dymonic 100 sealant over the four corners so that sealant grips the Securock ExoAir 430 membrane a minimum of 1" on all sides. Ensure there are no holes or gaps in the sealant and feather it out. Using a mil gauge, ensure that a minimum of 40 wet mils have been applied; if not, reapply sealant to achieve 40 wet mils.

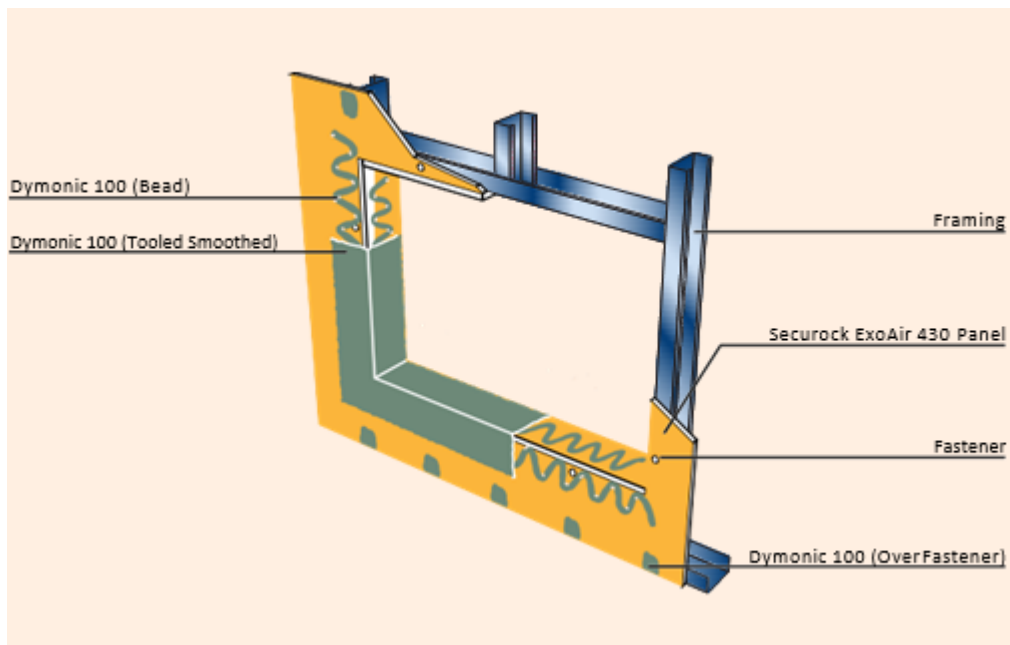

1.2 In rough opening:

- Securock 430 panel - 1" minimum
- Wood buck - determined by window placement/ design professional
- Steel framing - determined by window placement/ design professional

1.3 Tool Dymonic 100 (green) sealant on the face of the panel toward the rough opening ensuring the exposed core is covered with no holes or gaps. Feather sealant out onto the panel. Tool Dymonic 100 (green) sealant in the rough opening toward the face of the panel ensuring the exposed core is covered with no holes or gaps. Measure sealant to ensure that at least 40 wet mils have been applied; if not reapply Dymonic 100 (green) sealant.

1.4 For specific window connections, contact the local Sales Representative or Technical Services.

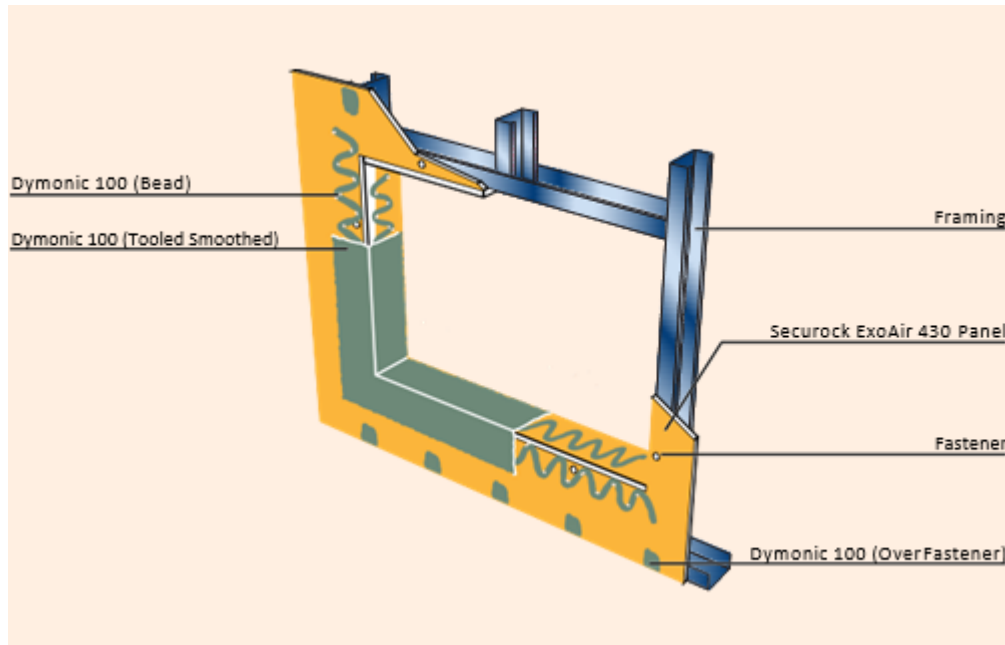

## 2. ROUGH OPENINGS - EXOAIR 110AT - DETAIL 13010, 13683, 15840

2.1 To properly install ExoAir 110AT, follow the steps in the order below. This allows for proper shingle effect of the membrane.

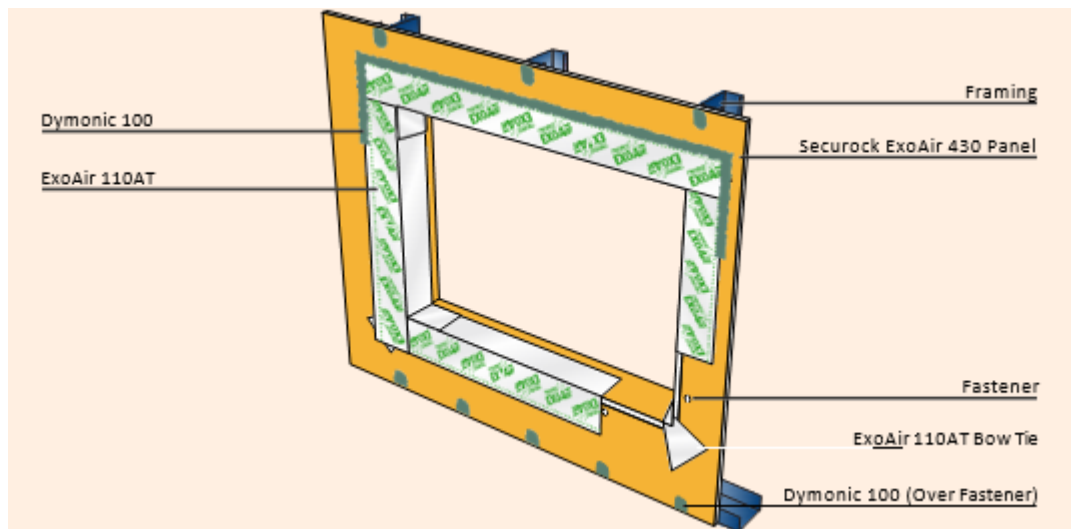

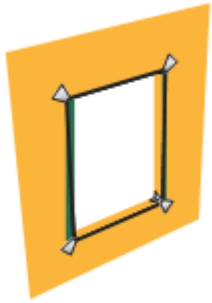

Cut ExoAir 110AT into four "bow tie" shapes. Length 6", top / bottom width 3", center 1". Remove backing and center the 1" section of the bow tie over face of joint. Press half onto the face of the panel and half into the rough opening. Mechanically roll to smooth out any fish mouths or air pockets in the membrane. Complete all four corners before applying flashing to the rough opening

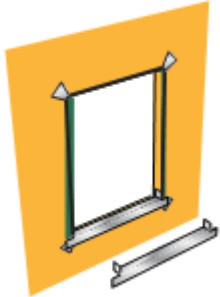

**Sill:** Cut a strip of ExoAir 110AT 6" longer than the length of the sill's opening. For example, a 36" sill will require a 42" strip of ExoAir 110AT. Fold the strip in half lengthwise. Make a 3" cut along the fold at each end so that you have two flaps. This will allow the sheet to be easily positioned into the rough opening and on to the exterior face of the panel.

Position the strip of ExoAir 110AT lengthwise on the sill so that the fold is on the front edge of the jamb and the flaps meet at both intersections of the sill and jambs. Press one flap on each side up into the rough opening in the jamb; then fold the membrane onto the exterior face of the panel covering the bow tie. Once positioned properly, remove the backing, smooth and press into place. Mechanically roll to smooth out any fish mouths or air pockets in the membrane.

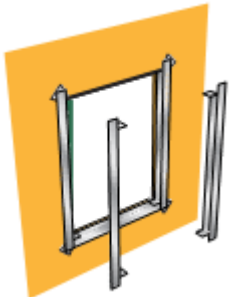

**Jambs:** Cut a strip of ExoAir 110AT 6" longer than the height of the jambs' opening. Make a 3" cut along the fold at each end so that you have two flaps. Apply the flashing on both jambs in the same fashion as used on the sill, this time adhering one flap up into the rough opening of the head; then fold the membrane onto the exterior face of the panel covering the bow tie. Once positioned properly, remove the backing and smooth and press into place. Mechanically roll ExoAir 110AT into place to smooth out any fish mouths or air pockets in the membrane.

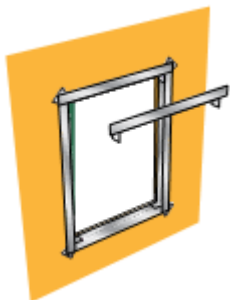

**Head:** Cut a strip of ExoAir 110AT 6" longer than the length of the head's opening. Cut the ends as instructed in 9.3.2 Apply the flashing on the head in the same fashion as used on the sill and jamb, this time adhering one flap down into the rough opening of each jamb; then fold the membrane on to the exterior face of the panel covering the bow tie. Once positioned properly, remove the backing and smooth and press into place. Mechanically roll to smooth out any fish mouths or air pockets in the membrane.

All ExoAir 110AT must lap a minimum of 2".

Apply a 40 mils thick, 1" wide bead of Dymonic 100 (green) sealant to top horizontal edge of ExoAir 110AT and extend 6" down the jambs on both sides.

To achieve air barrier continuity, it's imperative that ExoAir 110AT membrane be positioned so that it's smooth with no wrinkles, and thoroughly rolled out with firm pressure eliminating all fish mouths, gaps or air pockets at the membrane's vertical and horizontal edges. A visual inspection of each rough opening should be made to ensure proper installation. If there are no visual fish mouths, gaps or air pockets in the membrane, apply a 1/16" thick, 1" wide bead of Dymonic 100 (green) sealant to top horizontal edge of the ExoAir 110AT and extend 6" down the jambs on both sides and feather it out the top of the sealant to shed water. If any fish mouth, gap or air pocket remains after rolling, apply a 1/16" thick, 1" wide bead of Dymonic 100 (green) sealant to all edges of the ExoAir 110AT around the rough opening and all seams. Feather out sealant on all sides of the rough opening.

For specific window connections, contact the local Sales Representative or USG/Tremco Technical Services.

### 3. NAIL FLANGE – DYMONIC 100 SEALANT - DETAIL 15843, 14133, 14114

- 3.1 Refer to page 10, section 17.1, 17.2 and 17.3.
- 3.2 Press window into wet sealant and mechanically fasten to structure.
- 3.3 Immediately prior to installing the flanged window, apply generous bead of Dymonic 100 (green) around the rough opening placed in such a way so that the fasteners penetrate through the wet sealant and fasten to the structure.
- 3.4 Apply a generous bed of Dymonic 100 (green) sealant completely covering (minimum 1/2" overlap) all fasteners, feathering out beyond the flange onto the panel a minimum of 1/4".
- 3.5 Apply a continuous bead of Dymonic 100 (green) sealant in all four corners of the rough opening where the sill, jamb and head meet. Apply a continuous bead of Dymonic 100 (green) sealant in a zigzag pattern or a straight bead around the face of the panel, the sill, jambs and head. Tool Dymonic 100 sealant over the four corners so that sealant grips the Securock ExoAir 430 membrane a minimum of 1" on all sides. Ensure there are no holes or gaps in the sealant and feather it out. Using a mil gauge, ensure that a minimum of 40 wet mils have been applied; if not, reapply sealant to achieve 40 wet mils.

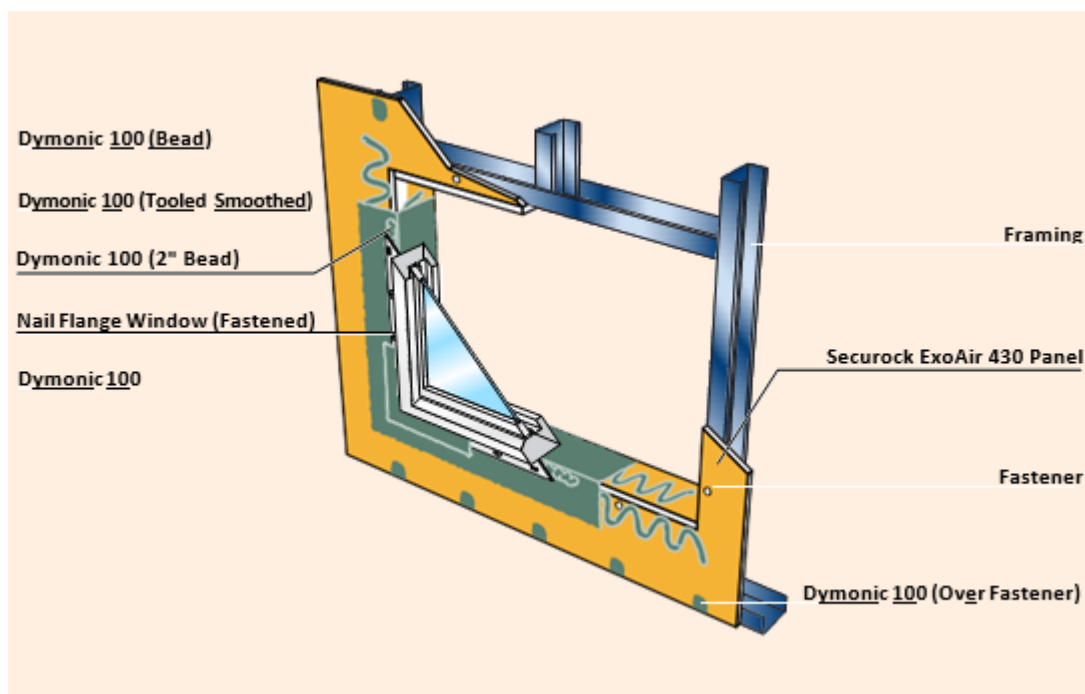

#### 4. NAIL FLANGE – EXOAIR 110AT - DETAIL 15847, 15844, 15842

4.1 To properly install ExoAir 110AT, follow the steps in the order below. This allows for proper shingle effect of the membrane.

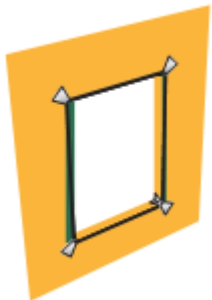
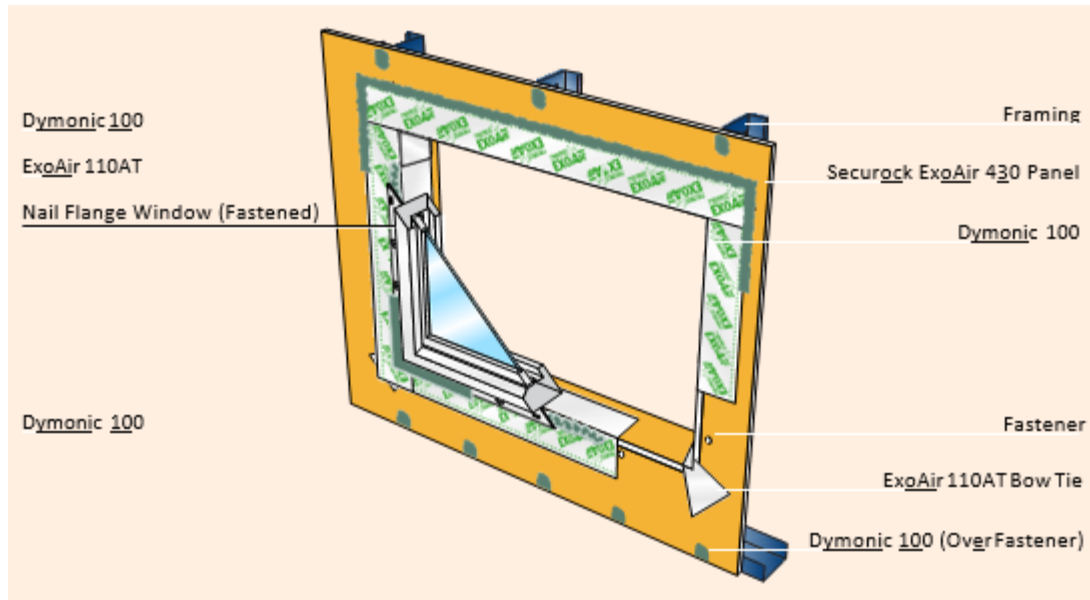

Cut ExoAir 110AT into four "bow tie" shapes. Length 6", top / bottom width 3", center 1". Remove backing and center the 1" section of the bow tie over face of joint. Press half onto the face of the panel and half into the rough opening. Mechanically roll to smooth out any fish mouths or air pockets in the membrane. Complete all four corners before applying flashing to the rough opening.

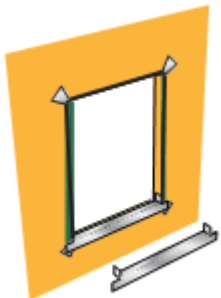

Sill: Cut a strip of ExoAir 110AT 6" longer than the length of the sill's opening. For example, a 36" sill will require a 42" strip of ExoAir 110AT. Fold the strip in half lengthwise. Make a 3" cut along the fold at each end so that you have two flaps. This will allow the sheet to be easily positioned into the rough opening and on to the exterior face of the panel.

Position the strip of ExoAir 110AT lengthwise on the sill so that the fold is on the front edge of the jamb and the flaps meet at both intersections of the sill and jambs. Press one flap on each side up into the rough opening in the jamb; then fold the membrane onto the exterior face of the panel covering the bow tie. Once positioned properly, remove the backing, smooth and press into place. Mechanically roll to smooth out any fish mouths or air pockets in the membrane.

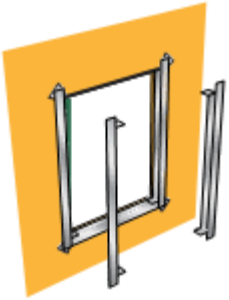

Jamb: Cut a strip of ExoAir 110AT 6" longer than the height of the jamb's opening. Make a 3" cut along the fold at each end so that you have two flaps. Apply the flashing on both jambs in the same fashion as used on the sill, this time adhering one flap up into the rough opening of the head; then fold the membrane onto the exterior face of the panel covering the bow tie. Once positioned properly, remove the backing and smooth and press into place. Mechanically roll ExoAir 110AT into place to smooth out any fish mouths or air pockets in the membrane.

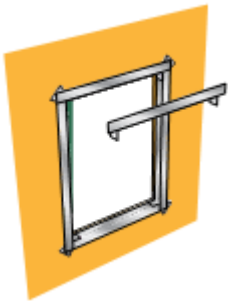

Head: Cut a strip of ExoAir 110AT 6" longer than the length of the head's opening. Cut the ends as instructed in 9.3.2 Apply the flashing on the head in the same fashion as used on the sill and jamb, this time adhering one flap down into the rough opening of each jamb; then fold the membrane on to the exterior face of the panel covering the bow tie. Once positioned properly, remove the backing and smooth and press into place. Mechanically roll to smooth out any fish mouths or air pockets in the membrane.

All ExoAir 110AT laps must lap a minimum of 2".

Apply a 1/4" thick, 1" wide bead of Dymonic 100 (green) sealant to top horizontal edge ExoAir 110AT and extend 6" down the jambs on both sides.

Immediately prior to installing the flanged window apply a continuous 1" wide by 1/8" thick bead of Dymonic 100 (green) sealant around rough opening placed in such a way so that the fasteners penetrate through the wet sealant and fasten to the structure.

Apply generous bead of Dymonic 100 (green) sealant, completely covering (minimum 1/2" overlap) all fasteners, feathering out beyond the flange onto the flashing a minimum 1/4".

---

## 13. Transitions

### 1. ADJACENT SUBSTRATES - DETAIL 13577

---

- 1.1 Dissimilar material connections need to be properly detailed. These steps below are intended to maintain the continuity between the Securock ExoAir 430 Panel and dissimilar materials with gaps 1" or less. For instruction on gaps with anticipated movement refer to section 13. For joints wider than 1" contact USG/Tremco Technical Services.
- 1.2 Fill joint completely with Dymonic 100 (green) sealant and tool flush. Dymonic 100 (green) does not have to cure before applying ExoAir 230.
- 1.3 Apply 70 wet mils of ExoAir 230 (light orange) and overlapping a minimum 3" onto the Securock ExoAir panel. Allow ExoAir 230 (light orange) to cure. Continue with Tremco field-applied air barrier system.

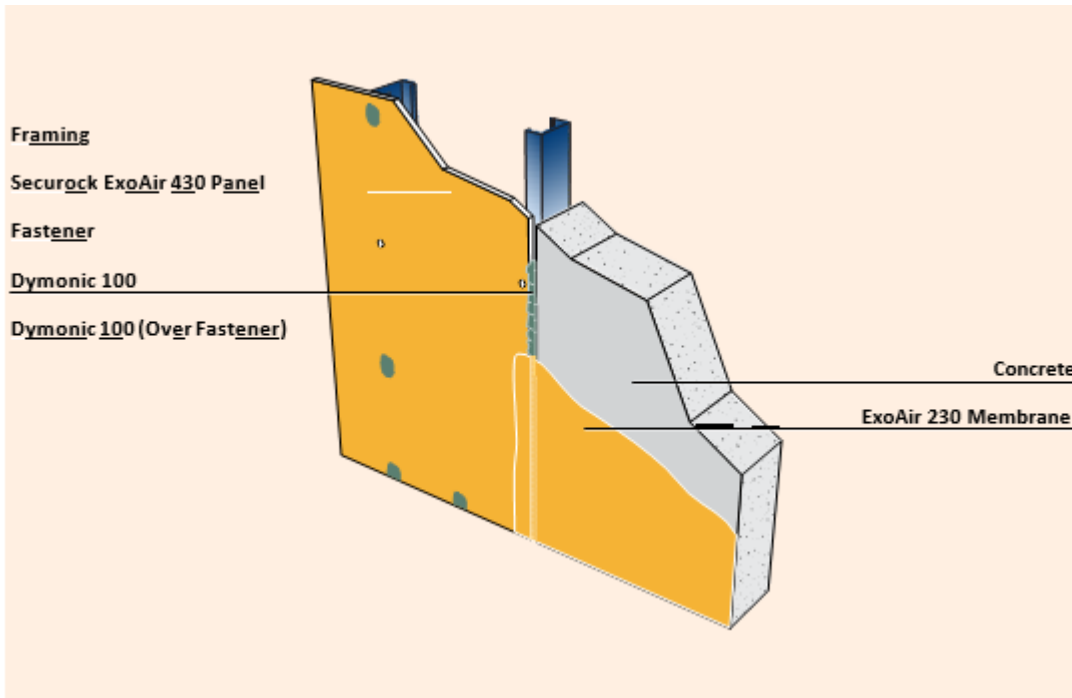

---

## 14. Repair Instructions

- 14.1 It is imperative to air barrier performance that the air barrier membrane applied to the board face not be compromised in any way. Compromises to the air barrier membrane can result from scratches, knife cuts, holes made in the panel or fastener penetration and withdrawal. If the air barrier membrane is compromised, the following procedures shall be followed to re-establish the air barrier membrane. If damage to either side of the panel compromises its structural integrity, the entire panel will need to be replaced.

### 1. SURFACE DAMAGE

---

- 1.1 **A:** Scratches or knife cuts to the membrane on the face side of the panel shall be repaired with a 40 mil application of Dymonic 100 (green) sealant.
- 1.2 **B:** Apply a 40 wet mill of Dymonic 100 (green) sealant over the damaged area extending 2" on all sides.
- 1.3 Spectrem 1 is an alternative to Dymonic 100, but cannot be used with an adhesively-applied cladding.

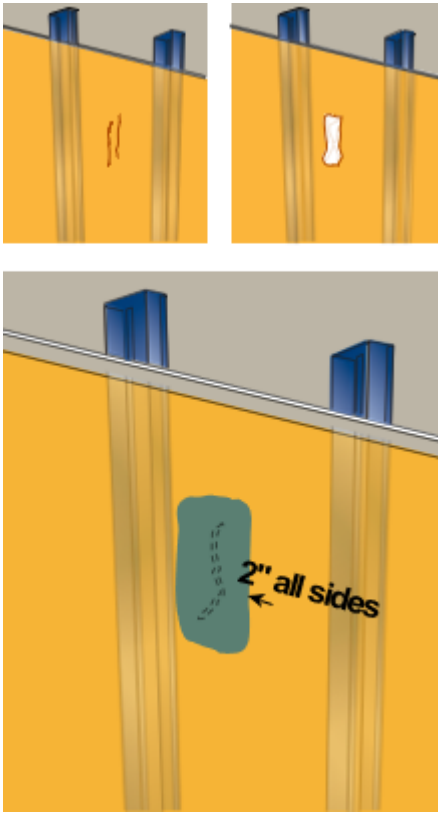

1.4

## 2. OPENINGS & GAPS



**A:** For openings or gaps smaller than 8" in any direction, the panel shall be repaired as follows. From another piece of Securock ExoAir 430 Panel, cut a section larger than the damaged area to be used as the repair piece. Place the cut piece over the damaged area ensuring that it covers all damage. Trace around the repair piece and cut, using a knife or jab saw, along the marking creating a hole in the damaged panel. When cutting the panel ensure that the gaps between repair piece and the damaged board shall not exceed 1/8".

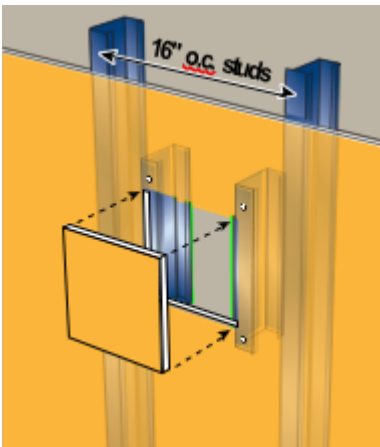

**B:** Use sections of drywall steel track to support the repair piece and fasten using screws. Ensure all surfaces are clean, dry and free of dust or debris.

**C:** Caulk all gaps with Dymonic 100 (green) sealant, completely filling the gaps and tool smooth.

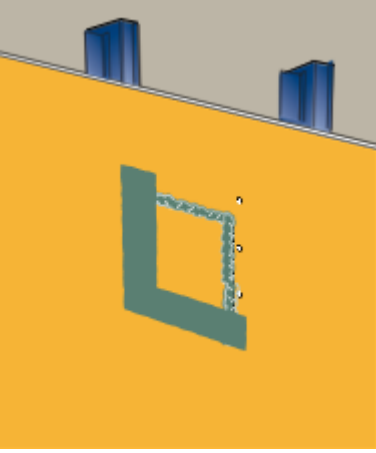

**D:** Apply Dymonic 100 (green) sealant at 40 mil thickness over the entire surface of the repair patch extending 2" beyond the gaps on all sides.

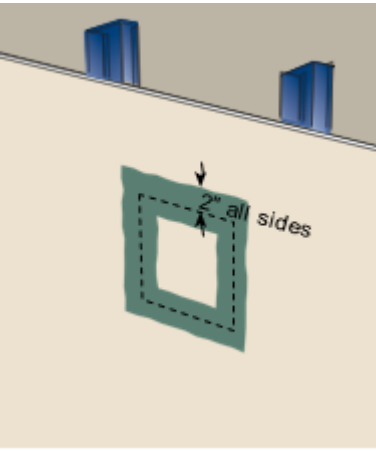

**A:** For openings or gaps larger than 8" in any direction, the panel shall be repaired as follows.

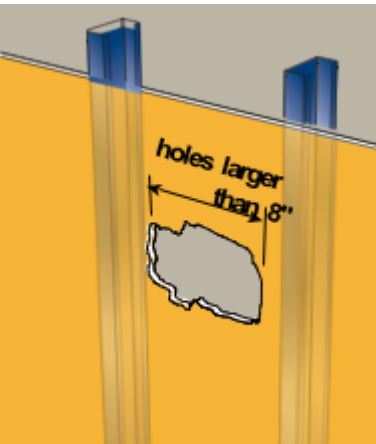

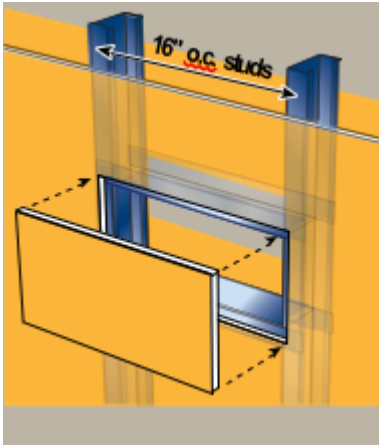

**B:** Cut the panel back to the framing on parallel sides. Cut a piece of Securock ExoAir 430 Panel to tightly fit into the opening and secure to framing with screws. Gaps between boards shall not exceed 1/8". Ensure all surfaces are clean, dry and free of dust or debris.

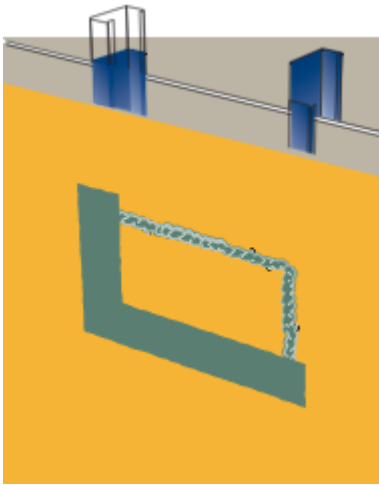

**C:** Caulk all gaps with Dymonic 100 (green) sealant, completely filling the gaps and tool smooth.

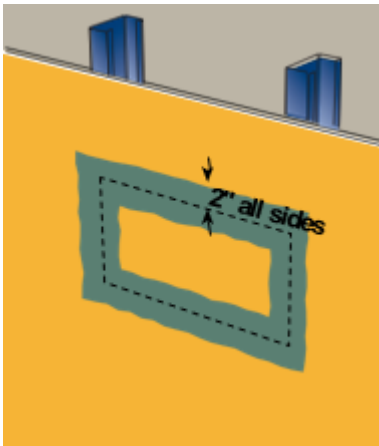

**D:** Apply Dymonic 100 (green) sealant at 40 mil thickness over the entire surface of the repair patch and extending 2" beyond the gaps on all sides.

---

## 15. Clean Up

- 15.1 Leftover material shall be removed from the job site.
- 15.2 Waste material shall be disposed of in a safe manner and in compliance with site, local, state and/or federal requirements.
- 15.3 Securock ExoAir 430 Panel shall be covered by an exterior cladding and is not intended for long-term exposure. Panels shall not be exposed to the elements for more than 12 months after it has been installed.

---

## 16. Selection Guide: Details & Critical Connections

16.1 These tools are intended to help understand the material vs labor cost of the above construction scenarios and outline the ideal application.

16.2 **MATERIAL REFERENCE GUIDE**

---

## 17. Available Details

17.1 See list of available details on [securrockexoair.com](http://securrockexoair.com)

Tremco Construction Products Group (CPG) brings together Tremco CPG Inc. and its Dryvit and Nudura brands; Willseal; Prebuck LLC; Tremco Barrier Solutions, Inc.; Weatherproofing Technologies, Inc. and its Pure Air Control Services and Canam Building Envelope Specialists offerings; and Weatherproofing Technologies Canada, Inc.



[tremcosealants.com](http://tremcosealants.com) | 800.321.7906



*Construction Products Group*

3735 Green Rd. | Beachwood, OH 44122  
800.321.7906 | [tremcocpg.com](http://tremcocpg.com)