

# BXUV.U469 - Fire-resistance Ratings - ANSI/UL 263

## Design/System/Construction/Assembly Usage Disclaimer

- Authorities Having Jurisdiction should be consulted in all cases as to the particular requirements covering the installation and use of UL Certified products, equipment, system, devices, and materials.
- Authorities Having Jurisdiction should be consulted before construction.
- Fire resistance assemblies and products are developed by the design submitter and have been investigated by UL for compliance with applicable requirements. The published information cannot always address every construction nuance encountered in the field.
- When field issues arise, it is recommended the first contact for assistance be the technical service staff provided by the product manufacturer noted for the design. Users of fire resistance assemblies are advised to consult the general Guide Information for each product category and each group of assemblies. The Guide Information includes specifics concerning alternate materials and alternate methods of construction.
- Only products which bear UL's Mark are considered Certified.

---

## BXUV - Fire Resistance Ratings - ANSI/UL 263 Certified for United States

## BXUV7 - Fire Resistance Ratings - CAN/ULC-S101 Certified for Canada

[See General Information for Fire-resistance Ratings - ANSI/UL 263 Certified for United States Design Criteria and Allowable Variances](#)

[See General Information for Fire Resistance Ratings - CAN/ULC-S101 Certified for Canada Design Criteria and Allowable Variances](#)

### **Design No. U469**

December 29, 2020

### **Assembly Rating — 1 HR**

### **Nonbearing Wall**

**\* Indicates such products shall bear the UL or cUL Certification Mark for jurisdictions employing the UL or cUL Certification (such as Canada), respectively.**

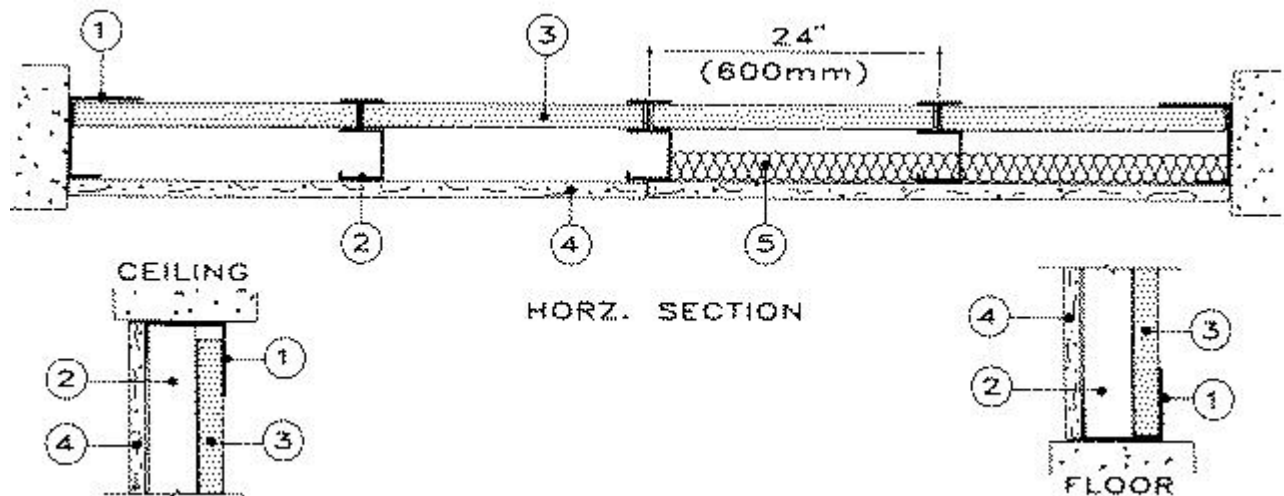

1. **Floor and Ceiling Runners** — "J" - shaped, 2-1/2 in. wide with unequal legs of 1 in. and 2 in., fabricated from 24 MSG galv steel (min 20 MSG steel required when Item 4A, 4B, or 4C is used). Runners attached to structural supports with steel fasteners located not greater than 2 in. from ends and not greater than 24 in. OC.

2. **Steel Studs** — "C-H" shaped studs, 2-1/2 in. wide by 1-1/2 in. deep, fabricated from min 25 MSG galv steel (min 20 MSG steel required when Item 4A, 4B, or 4C is used), spaced 24 in. or 600 mm OC (max 16 in. OC when Item 4A, 4B, or 4C is used). Vertically restrained walls require studs to be cut 3/8 in. less than floor to ceiling height.

3. **Gypsum Board\*** — 1 in. thick gypsum wallboard liner panels, supplied in nominal 24 in. or 600 mm widths. Vertical edges inserted in "H" shaped section of "C-H" studs. Free edge of end panels attached to long leg of "J" runners with 1-5/8 in. long Type S head steel screws spaced not greater than 12 in. OC.

**CERTAINTED GYPSUM INC** — Types Shaftliner, EGRG Shaftliner or GlasRoc Shaftliner

**CGC INC** — Type SLX.

**CERTAINTED GYPSUM INC** — Type LGFCSL

**GEORGIA-PACIFIC GYPSUM L L C** — Types TP-6, DGUSL, and TRSL

**UNITED STATES GYPSUM CO** — Type SLX

**USG BORAL DRYWALL SFZ LLC** — Type SLX

**USG MEXICO S A DE C V** — Type SLX.

4. **Gypsum Board\*** — 5/8 in. thick, 4 ft or 1200 mm wide, applied vertically and attached to studs with 1 in. long Type S steel screws spaced 12 in. OC along the edges and in the field of the boards.

**AMERICAN GYPSUM CO** — Types AGX-1, M-Glass, AG-C, LightRoc.

**CABOT MANUFACTURING ULG** — 5/8 Type X, Type Blueglass Exterior Sheathing

**CERTAINTED GYPSUM INC** — Type C, Type X, Type X-1.

**CGC INC** — Types C, IP-X1, IP-X2, IPC-AR, SCX, ULIX, ULX, or WRC.

**CERTAINTED GYPSUM INC** — Types LGFC-C, LGFC-C/A, LGFC6A

**GEORGIA-PACIFIC GYPSUM L L C** — Types 5, DAPC, Type X, Veneer Plaster Base - Type X, Water Rated - Type X, Sheathing - Type X, Soffit - Type X, Type TG-C, Type LWX, Veneer Plaster Base-Type LWX, Water Rated-Type LWX, Sheathing Type-LWX, Soffit-Type LWX, Type DGLW, Water Rated-Type DGLW, Sheathing Type- DGLW, Soffit-Type DGLW, Type LW2X, Veneer Plaster Base - Type LW2X, Water Rated - Type LW2X, Sheathing - Type LW2X, Soffit - Type LW2X, Type DGL2W, Water Rated - Type DGL2W, Sheathing - Type DGL2W, Type DGG, Type DAP, Type DS.

**PABCO BUILDING PRODUCTS L L C, DBA PABCO GYPSUM** — Types C, PG-11, PG-C, PGS-WRS, PGI

**SAINT-GOBAIN GYPROC MIDDLE EAST FZE** — Type Gyproc FireStop, Gyproc FireStop MR, Gyproc FireStop M2TECH, Gyproc FireStop ACTIV'Air, Gyproc FireStop MR ACTIV'Air, Gyproc FireStop M2TECH ACTIV'Air, Gyproc DuraLine, Gyproc DuraLine MR, Gyproc DuraLine M2TECH, Gyproc DuraLine ACTIV'Air, Gyproc DuraLine MR ACTIV'Air, Gyproc DuraLine M2TECH ACTIV'Air

**THAI GYPSUM PRODUCTS PCL** — Type C.

**UNITED STATES GYPSUM CO** — Types C, FRX-G, IP-X1, IP-X2, IPC-AR, SCX, ULIX, ULX or WRC.

**USG BORAL DRYWALL SFZ LLC** — Types C, SCX

**USG MEXICO S A DE C V** — Types C, IP-X1, IP-X2, IPC-AR, SCX, ULX, or WRC.

4A. **Gypsum Board\*** — Not Shown - As an Alternate to Item 4. Nom 5/8 in. thick lead backed gypsum panels with beveled, square or tapered edges, applied vertically. Vertical joints centered over studs and staggered min 1 stud cavity on opposite sides of studs. Wallboard secured to studs with 1-1/4 in. long Type S-12 steel screws spaced 8 in. OC at perimeter and 12 in. OC in the field. Lead batten strips (Item 6) required behind vertical joints

**RAY-BAR ENGINEERING CORP** — Type RB-LBG

4B. **Gypsum Board\*** — Not Shown - As an Alternate to Item 4. Nom 5/8 in. thick lead backed gypsum panels with beveled, square or tapered edges, applied vertically. Vertical joints centered over studs and staggered min 1 stud cavity on opposite sides of studs. Wallboard secured to studs with 1-1/4 in. long Type S-12 steel screws spaced 8 in. OC at perimeter and 12 in. OC in the field. Lead batten strips required behind vertical joints. To be used with Lead Batten Strips (see Item 6B) or Lead Discs (see Item 6C).

**MAYCO INDUSTRIES INC** — Type X-Ray Shielded Gypsum

4C. **Gypsum Board\*** — (Not Shown - As an Alternate to Item 4.). Nom 5/8 in. thick lead backed gypsum panels with beveled, square or tapered edges, applied vertically. Vertical joints centered over studs and staggered min 1 stud cavity on opposite sides of studs. Wallboard secured to studs with 1-1/4 in. long Type S-12 steel screws gypsum panel steel screws spaced 8 in. OC at perimeter and 12 in. OC in the field. Lead batten strips required behind vertical joints of lead backed gypsum wallboard and optional at remaining stud locations. Lead batten strips, min 2 in. wide, max 8 ft long with a max thickness of 0.14 in. placed on the face of studs and attached to the stud with construction adhesive and two 1 in. long Type S-12 pan head steel screws, one at the top of the strip and one at the bottom of the strip. Lead discs, nominal 3/8 in. diam by max 0.085 in. thick. Compression fitted or adhered over the screw heads. Lead batten strips and discs to have a purity of 99.9% meeting the Federal specification QQ-L-201f, Grade "C".

**RADIATION PROTECTION PRODUCTS INC** — Type RPP - Lead Lined Drywall

5. **Batts and Blankets\*** — (Optional) — Mineral wool batts partially or completely filling stud cavity.

**ROCKWOOL** — Type AFB, min. density 1.8 pcf / 28.8 kg/m<sup>3</sup>

**THERMAFIBER INC** — Type SAFB, SAFB FF

5A. **Fiber, Sprayed\*** — As an alternate to Batts and Blankets (Item 5) — (100% Borate Formulation) — Spray applied cellulose material. The fiber is applied with water to completely fill the enclosed cavity in accordance with the application instructions supplied with the product with a nominal dry density of 2.7 lb/ft<sup>3</sup>. Alternate Application Method: The fiber is applied without water or adhesive at a nominal dry density of 3.5 lb/ft<sup>3</sup>, in accordance with the application instructions supplied with the product.

**U S GREENFIBER L L C** — INS735, INS745 and INS750LD for use with wet or dry application. INS765LD and INS773LD are to be used for dry application only.

5B. **Fiber, Sprayed\*** — As an alternate to Batts and Blankets (Item 5) - Spray applied cellulose insulation material. The fiber is applied with water to interior surfaces in accordance with the application instructions supplied with the product. Applied to completely fill the enclosed cavity. Minimum dry density of 4.3 pounds per cubic ft.

**NU-WOOL CO INC** — Cellulose Insulation

5C. **Fiber, Sprayed\*** — As an alternate to Batts and Blankets (Item 5) - Spray applied cellulose fiber. The fiber is applied with water to completely fill the enclosed cavity in accordance with the application instructions supplied with the product. The minimum dry density shall be 4.30 lbs/ft<sup>3</sup>.

**INTERNATIONAL CELLULOSE CORP** — Celbar-RL

5D. Deleted.

5E. **Fiber, Sprayed\*** — As an alternate to Batts and Blankets (Item 5) - Spray-applied cellulose material. The fiber is applied with water to completely fill the enclosed cavity in accordance with the application instructions supplied with the product. To facilitate the installation of the material, any thin, woven or non-woven netting may be attached by any means possible to the outer face the studs. The material shall reach equilibrium moisture content before the installation of materials on either face of the studs. The minimum dry density shall be 5.79 lbs/ft<sup>3</sup>.

**APPLEGATE HOLDINGS L L C** — Applegate Advanced Stabilized Cellulose Insulation

6. **Lead Batten Strips** — For Use with Item 4A - (Not Shown) — Lead batten strips required behind vertical joints of lead backed gypsum wallboard (Item 4A) and optional at remaining stud locations. Strips, min 1-1/2 in. wide, max 10 ft long with a max thickness of 0.125 in. Strips placed on the interior face of studs and attached from the exterior face of the stud with two 1 in. long Type S-12 pan head steel screws, one at the top of the strip and one at the bottom of the strip. Lead batten strips to have a purity of 99.9% meeting the Federal specification QQ-L-201f, Grade "C".

6A. **Lead Discs or Tabs** — (Not Shown) - Used in lieu of or in addition to the lead batten strips (Item 6) or optional at other locations - Max 3/4 in. diam by max 0.125 in. thick lead discs compression fitted or adhered over steel screw heads or max 1/2 in. by 1-1/4 in. by max 0.125 in. thick lead tabs placed on gypsum boards (Item 5) underneath screw locations prior to the installation of the screws. Lead discs or tabs to have a purity of 99.9% meeting the Federal specification QQ-L-201f, Grade "C".

6B. **Lead Batten Strips** — (Not Shown, for use with Item 4B) Lead batten strips, 2 in. wide, max 10 ft long with a max thickness of 0.140 in. Strips placed on the face of studs and attached to the stud with two min. 1 in. long min. Type S-8 pan head steel screws, one at the top of the strip and one at the bottom of the strip or with one min. 1 in. long min. Type S-8 pan head steel screw at the top of the strip. Lead batten strips to have a purity of 99.5% meeting the Federal specification QQ-L-201f, Grades "B, C or D".

6C. **Lead Discs** — (Not Shown, for use with Item 4B) Max 5/16 in. diam by max 0.140 in. thick lead discs compression fitted or adhered over steel screw heads. Lead discs to have a purity of 99.5% meeting the Federal Specification QQ-L-201f, Grades "B, C or D".

**\* Indicates such products shall bear the UL or cUL Certification Mark for jurisdictions employing the UL or cUL Certification (such as Canada), respectively.**

Last Updated on 2020-12-29

---

The appearance of a company's name or product in this database does not in itself assure that products so identified have been manufactured under UL's Follow-Up Service. Only those products bearing the UL Mark should be considered to be Certified and covered under UL's Follow-Up Service. Always look for the Mark on the product.

UL permits the reproduction of the material contained in the Online Certification Directory subject to the following conditions: 1. The Guide Information, Assemblies, Constructions, Designs, Systems, and/or Certifications (files) must be presented in their entirety and in a non-misleading manner, without any manipulation of the data (or drawings). 2. The statement "Reprinted from the Online Certifications Directory with permission from UL" must appear adjacent to the extracted material. In addition, the reprinted material must include a copyright notice in the following format: "© 2022 UL LLC"