

Design/System/Construction/Assembly Usage Disclaimer

- Authorities Having Jurisdiction should be consulted in all cases as to the particular requirements covering the installation and use of UL Certified products, equipment, system, devices, and materials.
- Authorities Having Jurisdiction should be consulted before construction.
- Fire resistance assemblies and products are developed by the design submitter and have been investigated by UL for compliance with applicable requirements. The published information cannot always address every construction nuance encountered in the field.
- When field issues arise, it is recommended the first contact for assistance be the technical service staff provided by the product manufacturer noted for the design. Users of fire resistance assemblies are advised to consult the general Guide Information for each product category and each group of assemblies. The Guide Information includes specifics concerning alternate materials and alternate methods of construction.
- Only products which bear UL's Mark are considered Certified.

BXUV – Fire Resistance Ratings – ANSI/UL 263 Certified for United States

BXUV7 – Fire Resistance Ratings – CAN/ULC-S101 Certified for Canada

[See General Information for Fire-resistance Ratings – ANSI/UL 263 Certified for United States Design Criteria and Allowable Variances](#)

[See General Information for Fire Resistance Ratings – CAN/ULC-S101 Certified for Canada Design Criteria and Allowable Variances](#)

Design No. U438

November 14, 2025

Nonbearing Wall Rating – 2 HR.

* Indicates such products shall bear the UL or cUL Certification Mark for jurisdictions employing the UL or cUL Certification (such as Canada), respectively.

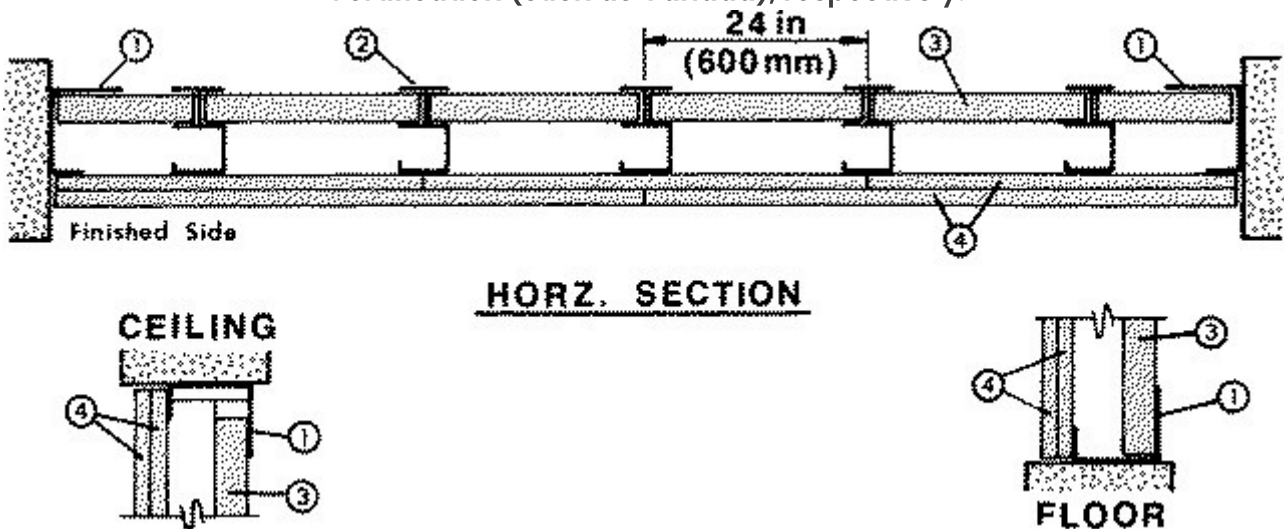

1. **Floor and Ceiling Runners** — "J" -shaped runner, 2-1/2 in. wide with unequal legs of 1 in. and 2 in., fabricated from 24 MSG galv steel (min 20 MSG when Item 4B is used). Runners positioned with short leg toward finished side of wall. Runners attached to structural supports with steel fasteners located not greater than 2 in. from ends and not greater than 24 in. OC.

2. **Steel Studs** — "C-H" -shaped studs, 2-1/2 in. wide by 1-1/2 in. deep, fabricated from 25 MSG galv steel (min 20 MSG when Item 4B, 4D, or 4E is used). Cut to lengths 3/8 to 1/2 in. less than floor to ceiling height and spaced 24 in. or 600 mm OC (max 16 in. OC when Items 4B, 4D, 4E is used).

2A. **Steel Studs** — (Not shown)-"E" -shaped studs installed in place of "C-H" -shaped studs (Item 2) to secure the closure liner panels at the ends of walls. Fabricated from 25 MSG galv steel (min 20 MSG when Item 4B, 4D, or 4E is used), 2-1/2 in. wide, with one leg 1 in. long and two legs 3/4 in. long. Shorter legs 1 in. apart to engage gypsum liner panels. Cut to lengths 3/8 in. less than floor to ceiling height. Sill and lintel of opening formed with "J" -shaped runners (Item 1) secured to "E" -shaped studs with angle clips and steel screws.

3. **Gypsum Board*** — 1 in. thick gypsum wallboard liner panels, supplied in nom 24 in. or 600 mm (for metric spacing) widths. Panels cut 1 in. less in length than floor to ceiling height. Vertical edges inserted in "H" -shaped section of "C-H" studs. Free edge of end panels attached to long leg of "J" -runners with 1-5/8 in. long Type S steel screws spaced not greater than 12 in. OC.

CGC INC — Type SLX.

CERTAINTED GYPSUM INC — Type Shaftliner, LGFCSL

NATIONAL GYPSUM CO — FSW, FSW - 7

UNITED STATES GYPSUM CO — Type SLX.

USG BORAL DRYWALL SFZ LLC — Type SLX

USG MEXICO S A DE C V — Type SLX.

4. **Gypsum Board*** — 1/2 in. thick, 4 ft. or 1200 mm (for metric spacing) wide wallboard applied vertically in two layers. Inner or base layer attached to studs with 1 in. long Type S steel screws spaced 24 in. OC along the edges and in the field of the boards. Outer or face layer attached to studs and "J" -runners with 1-5/8 in. long Type S steel screws spaced 12 in. along the edges and in the field of the boards, staggered from screws in inner layer. Joints between inner and outer layers staggered.

Outer layer joints covered with paper tape and joint compound. Exposed screw heads covered with joint compound.

As an alternate method, inner wallboard layer applied vertically, outer wallboard layer applied horizontally. Inner layer attached to studs with 1 in. Type S steel screws spaced 24 in. OC along vertical edges and in the field. Outer layer attached to the studs and "J" runners over the inner layer with 1-5/8 in.

long Type S steel screws spaced 12 in. OC in the field, along the vertical edges and to the floor and ceiling runners. Outer layer secured to inner layer wallboard with 1-1/2 in. long Type G steel screws located midway between studs and 1 in. from the horizontal joint.

AMERICAN GYPSUM CO — Types AG-C .

CABOT MANUFACTURING ULC — Type C

CERTAINTED GYPSUM INC — Type C

CGC INC — Type C, IP-X2, or WRC.

GEORGIA-PACIFIC GYPSUM L L C — Types 5, DAPC, TG-C.

NATIONAL GYPSUM CO — Types eXP-C, FSK-C, FSW-C, FSMR-C.

PABCO BUILDING PRODUCTS L L C, DBA PABCO GYPSUM — Types PG-C.

SAINT-GOBAIN GYPROC MIDDLE EAST FZE — Type Gyproc FireStop, Gyproc FireStop MR, Gyproc FireStop M2TECH, Gyproc FireStop ACTIV'Air, Gyproc FireStop MR ACTIV'Air, Gyproc FireStop M2TECH ACTIV'Air

THAI GYPSUM PRODUCTS PCL — Type C.

UNITED STATES GYPSUM CO — Type C, IP-X2 or WRC.

USG BORAL DRYWALL SFZ LLC — Type C

USG MEXICO S A DE C V — Type C, IP-X2 or WRC.

4A. Gypsum Board* — (As an alternate to Item 4) — 5/8 in. thick gypsum panels with beveled, square or tapered edges, applied vertically or horizontally. Inner or base layer attached to studs with 1 in. long Type S or S-12 steel screws spaced 24 in. OC when installed vertically or 16 in. OC when installed horizontally. Outer or face layer attached to studs with 1-5/8 in. long Type S or S-12 steel screws spaced 12 in. OC when installed vertically and staggered 12 in. from base layer screws or 8 in. OC when installed horizontally and staggered 8 in. from base layer screws. Horizontal joints between inner and outer layers staggered a min of 12 in. Horizontal joints need not be backed by steel framing. Vertical joints centered over studs and staggered 24 in. Outer layer joints covered with paper tape and joint compound. Exposed screw heads covered with joint compound. Paper tape and joint compound may be omitted when gypsum boards are supplied with square edges. When used in widths other than 48 in., gypsum panels to be installed horizontally.

CGC INC — Type AR, IP-AR, IP-X1, SCX, ULX, or WRX.

UNITED STATES GYPSUM CO — Type AR, FRX-G, IP-AR, IP-X1, SCX, ULX or WRX.

USG BORAL DRYWALL SFZ LLC — Type SCX

USG MEXICO S A DE C V — Type AR, IP-AR, IP-X1, SCX, ULX, or WRX.

4B. Gypsum Board* — (Not Shown) - May be used in lieu of Items 4 or 4A for the base layer - Nom 5/8 in. thick lead backed gypsum panels with beveled, square or tapered edges, applied vertically. Vertical joints centered over studs and staggered min 1 stud cavity on opposite sides of studs. Wallboard secured to studs with 1-1/4 in. long Type S-12 steel screws spaced 8 in. OC at perimeter and 12 in. OC in the field. Lead batten strips (Item 6) required behind vertical joints.

RAY-BAR ENGINEERING CORP — Type RB-LBG

4C. Gypsum Board* — (As an alternate to Item 4, 4A, 4B) — 5/8 in. thick. Two layers installed as described in Item 4.

NATIONAL GYPSUM CO — Type FSMR-C, FSW-C, FSK-C, eXP-C.

4D. Gypsum Board* — (Not Shown) - May be used in lieu of Items 4 for the base layer - Nom 5/8 in. thick lead backed gypsum panels with beveled, square or tapered edges, applied vertically. Vertical joints centered over studs and staggered min 1 stud cavity on opposite sides of studs. Wallboard secured to studs with 1-1/4 in. long Type S-12 steel screws spaced 8 in. OC at perimeter and 12 in. OC in the field. Lead batten strips required behind vertical joints. To be used with Lead Batten Strips (see Item 6B) or Lead Discs (see Item 6C).

MAYCO INDUSTRIES INC — Type X-Ray Shielded Gypsum

4E. Gypsum Board* — (Not Shown) - May be used in lieu of Items 4 for the base layer. Nom 5/8 in. thick lead backed gypsum panels with beveled, square or tapered edges, applied vertically. Vertical joints centered over studs and staggered min 1 stud cavity on opposite sides of studs. Wallboard secured to studs with 1-1/4 in. long Type S-12 steel screws gypsum panel steel screws spaced 8 in. OC at perimeter and 12 in. OC in the field. Lead batten strips required behind vertical joints of lead backed gypsum wallboard and optional at remaining stud locations. Lead batten strips, min 2 in. wide, max 8 ft long with a max thickness of 0.14 in. placed on the face of studs and attached to the stud with construction adhesive and two 1 in. long Type S-12 pan head steel screws, one at the top of the strip and one at the bottom of the strip. Lead discs, nominal 3/8 in. diam by max 0.085 in. thick. Compression fitted or adhered over the screw heads. Lead batten strips and discs to have a purity of 99.9% meeting the Federal specification QQ-L-201f, Grade "C".

RADIATION PROTECTION PRODUCTS INC — Type RPP - Lead Lined Drywall

4F. Gypsum Board* — (As an alternate to Item 4) — 5/8 in. thick gypsum panels with beveled, square or tapered edges, applied vertically or horizontally. Inner or base layer attached to studs with 1 in. long Type S or S-12 steel screws spaced 24 in. OC when installed vertically or 16 in. OC when installed horizontally. Outer or face layer attached to studs with 1-5/8 in. long Type S or S-12 steel screws spaced 8 in. OC when installed vertically and staggered min. 8 in. from base layer screws or 8 in. OC when installed horizontally and staggered min. 6 in. from base layer screws. Horizontal joints between inner and outer layers need not to be staggered. Horizontal joints need not be backed by steel framing. Vertical joints centered over studs and staggered 24 in. Outer layer joints covered with paper tape and joint compound. Exposed

screw heads covered with joint compound. When used in widths other than 48 in., gypsum panels to be installed horizontally.

CGC INC — Type ULIX.

UNITED STATES GYPSUM CO — Type ULIX.

4G. Gypsum Board* - 5/8 in. thick, 4 ft wide wallboard applied vertically in two layers. Inner or base layer attached to studs with 1 in. long Type S or S-12 steel screws spaced 24 in. OC along the edges and in the field of the boards. Outer or face layer attached to studs and "J" shaped runners with 1-5/8 in. long Type S or S-12 steel screws spaced 12 in. along the edges and in the field of the boards, staggered from screws in inner layer. Joints between inner and outer layers staggered. Outer layer joints covered with paper or mesh tape and joint compound. Exposed screw heads covered with joint compound.

NATIONAL GYPSUM CO — eXP-C, FSK, FSK-C, FSW, FSW-C, FSW-3, FSW-5, FSW-6

CERTAINTED GYPSUM INC — Type X-1

4H. Gypsum Board* — (As an alternate to Item 4) - For use with 1 in. Type FSW-7 gypsum board (Item 3) only. 5/8 in. thick, 4 ft wide, applied in two layers. Base layer attached vertically to studs and side "J" runners with 1 in. long Type S self-tapping steel screws spaced 16 in. OC. Face layer installed vertically to studs and side "J" runners and attached with 1-5/8 in. long Type S self-tapping steel screws spaced 12 in. OC. Face layer vertical joints staggered minimum one stud cavity from base layer vertical joints. Face layer joints covered with paper tape and two coats of joint compound. Exposed screw heads covered with two coats of joint compound.

NATIONAL GYPSUM CO — Type FSLX

5. Batts and Blankets* — (Optional) — (Not shown) — Mineral wool or glass fiber batts partially or completely filling stud cavity. Any mineral wool or glass fiber batt material bearing the UL Classification Marking as to Fire Resistance.

5A. Fiber, Sprayed* — As an alternate to Batts and Blankets (Item 5) — (100% Borate Formulation) — Spray applied cellulose material. The fiber is applied with water to completely fill the enclosed cavity in accordance with the application instructions supplied with the product with a nominal dry density of 2.7 lb/ft³. Alternate Application Method: The fiber is applied without water or adhesive at a nominal dry density of 3.5 lb/ft³, in accordance with the application instructions supplied with the product.

Applegate Greenfiber Acquisition LLC — Insulmax and SANCTUARY for use with wet or dry application.

5B. Fiber, Sprayed* — As an alternate to Batts and Blankets (Item 5) - Spray applied cellulose insulation material. The fiber is applied with water to interior surfaces in accordance with the application instructions supplied with the product. Applied to completely fill the enclosed cavity. Minimum dry density of 4.3 pounds per cubic ft.

NU-WOOL CO INC — Cellulose Insulation

5C. Fiber, Sprayed* — As an alternate to Batts and Blankets (Item 5) – Spray applied cellulose fiber. The fiber is applied with water to completely fill the enclosed cavity in accordance with the application instructions supplied with the product. The minimum dry density shall be 4.30 lbs/ft³.

INTERNATIONAL CELLULOSE CORP — Celbar-RL

5D. Fiber, Sprayed* — As an alternate to Batts and Blankets (Item 5) — Spray-applied cellulose material. The fiber is applied with water to completely fill the enclosed cavity in accordance with the application instructions supplied with the product. To facilitate the installation of the material, any thin, woven or non-woven netting may be attached by any means possible to the outer face the studs. The material shall reach equilibrium moisture content before the installation of materials on either face of the studs. The minimum dry density shall be 5.79 lbs/ft³.

Applegate Greenfiber Acquisition LLC— Applegate Advanced Stabilized Cellulose Insulation

6. Lead Batten Strips — For Use with Item 4B - (Not Shown) - Lead batten strips required behind vertical joints of lead backed gypsum wallboard (Item 4A) and optional at remaining stud locations. Strips, min 1-1/2 in. wide, max 10 ft long with a max thickness of 0.125 in. Strips placed on the interior face of studs and attached from the exterior face of the stud with two 1 in. long Type S-12 pan head steel screws, one at the top of the strip and one at the bottom of the strip. Lead batten strips to have a purity of 99.9% meeting the Federal specification QQ-L-201f, Grade "C".

6A. Lead Discs or Tabs — (Not Shown) - Used in lieu of or in addition to the lead batten strips (Item 6) or optional at other locations - Max 3/4 in. diam by max 0.125 in. thick lead discs compression fitted or adhered over steel screw heads or max 1/2 in. by 1-1/4 in. by max 0.125 in. thick lead tabs placed on gypsum boards (Item 5) underneath screw locations prior to the installation of the screws. Lead discs or tabs to have a purity of 99.9% meeting the Federal specification QQ-L-201f, Grade "C".

6B. Lead Batten Strips — (Not Shown, for use with Item 4D) Lead batten strips, 2 in. wide, max 10 ft long with a max thickness of 0.140 in. Strips placed on the face of studs and attached to the stud with two min. 1 in. long min. Type S-8 pan head steel screws, one at the top of the strip and one at the bottom of the strip or with one min. 1 in. long min. Type S-8 pan head steel screw at the top of the strip. Lead batten strips to have a purity of 99.5% meeting the Federal specification QQ-L-201f, Grades "B, C or D". Lead batten strips required behind vertical joints of lead backed gypsum wallboard and optional at remaining stud locations.

6C. Lead Discs — (Not Shown, for use with Item 4D) Max 5/16 in. diam by max 0.140 in. thick lead discs compression fitted or adhered over steel screw heads. Lead discs to have a purity of 99.5% meeting the Federal Specification QQ-L-201f, Grades "B, C or D".

*** Indicates such products shall bear the UL or cUL Certification Mark for jurisdictions employing the UL or cUL Certification (such as Canada), respectively.**

Last Updated on 2025-11-14

The appearance of a company's name or product in this database does not in itself assure that products so identified have been manufactured under UL Solutions' Follow - Up Service. Only those products bearing the UL Mark should be considered to be Certified and covered under UL Solutions' Follow - Up Service. Always look for the Mark on the product.

UL Solutions permits the reproduction of the material contained in Product iQ subject to the following conditions: 1. The Guide Information, Assemblies, Constructions, Designs, Systems, and/or Certifications (files) must be presented in their entirety and in a non-misleading manner, without any manipulation of the data (or drawings). 2. The statement "Reprinted from Product iQ with permission from UL Solutions" must appear adjacent to the extracted material. In addition, the reprinted material must include a copyright notice in the following format: "©2026 UL LLC."