

# COMPÄSSO™ TRIM SYSTEMS

## DESIGN GUIDE



IT'S YOUR WORLD. BUILD IT.®

**OFFICES**  
**SCHOOLS**  
**RETAIL**  
**ENTERTAINMENT**



Architect: Crabtree, Rohrbaugh & Associates - Architects  
Photo: © Crabtree, Rohrbaugh & Associates - Architects

Compasso™ Trim Systems and C<sup>2</sup> Paired Compasso Channels provide an elegant finishing touch that dresses up acoustical ceiling assemblies integrating lighting with eye-catching design elements. These unique ceiling accents combine dramatic styling and practicality to make a striking statement in retail spaces, contemporary offices, entertainment and gaming establishments, and education environments.

# User's Guide

COMPASSO family of suspension trims creates a clean streamlined edge for floating acoustical ceiling assemblies and allows a smooth visual transition among multiple ceiling islands within a space.

	Page		Page
<b>Choose Your System</b>	<b>4</b>	<b>COMPASSO Standard</b> This steel (10" & 12" aluminum) suspension trim with a durable baked-on polyester finish can accommodate all USG ceiling systems and has been the industry choice since its inception and introduction to the market more than a decade ago. In addition to its economy, COMPASSO Standard is a great value to accent any ceiling. It is a particularly good choice for open-cell grid ceilings because of its unobtrusive splices and grid clips. COMPASSO Standard is available in both engineered curved shapes as well as quick ship bulk cartons.	<b>8</b> <b>COMPASSO Elite</b> Manufactured from up to 50% recycled aluminum, COMPASSO Elite provides cleaner, sharper lines that only an extrusion can provide. With its durable powder-coated finish, it presents elegance with its subtle reveal that will accent the look of any USG ceiling system to present a more refined aesthetic. COMPASSO Elite is available in both engineered curved shapes as well as quick ship bulk cartons.
	<b>12</b>	<b>COMPASSO Slim</b> Extruded from highly recycled aluminum, COMPASSO Slim transforms any USG Ceiling system into a sleek, plane terminated at the perimeter with a broad horizontal picture frame with mitered corners.	<b>22</b> <b>COMPASSO C<sup>2</sup></b> C <sup>2</sup> Paired COMPASSO Channels are multi-functional design elements that easily integrate lighting and signage, and can be used as a way-finding device throughout a space. These unique ceiling accents combine practicality with dynamic styling for retail spaces, contemporary offices, entertainment
<b>How</b>		<b>Design It</b>  <b>Pre-engineered, any color, any shape, designed and packaged, ready to assemble</b>  <b>Quick Ship, three colors</b>	
<b>Specify Your System</b>	<b>18</b>  <b>36</b>	<b>Design Your System</b>  <b>Specify Your System</b>	
<b>For More Information</b>		<b>Technical Service</b> <b>800 USG.4YOU</b> <b>Website</b> <b>usg.com</b>	

# Compásso Suspension Trim Systems

---

COMPASSO Trim Systems complement standard grid and tile by providing a finished edge whether it's curved or straight. The trimming concept allows for the creation of ceiling islands or fascias. It also lends visual excitement to any space, especially retail spaces, contemporary office environments, entertainment and gaming establishments, and education environments. Read on for details on how to design and specify COMPASSO Trim Systems in your next project.

---

## **Design Flexibility**

COMPASSO Trim Systems are available in different trim heights and profiles custom manufactured to your design specifications. From the utility of COMPASSO Standard to the elegance of COMPASSO Elite, there is a trim system to meet your needs. For even greater design flair, consider either COMPASSO Slim horizontal trim or C<sup>2</sup> paired COMPASSO channels.

---

## **Functional Style**

COMPASSO Trim Systems finish standard ceiling grid, panels, lighting, and air diffusers to create crisp edge conditions and unique floating islands. You can also create graceful, flowing arcs, curves, and circles. Use any USG suspension system and panel. Combine straight and curved pieces to form a ceiling perimeter of almost any size or shape you can imagine. Squares, triangles, rectangles, circles, ellipses. No problem.



---

## **Available Colors**

COMPASSO Trim Systems are available in standard and custom colors and can be painted 360° when used with the GRIDWARE Suspension System to create open-cell ceilings. For help choosing a custom color, the Sherwin-Williams Color Answers Selector is a good reference.

# System Options Overview

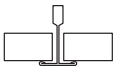
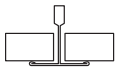
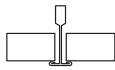
System Options	Heights						Quick Ship	Engineered	Advantage Colors*	Timbre™
	2"	4"	6"	8"	10"	12"				
COMPASSO Standard	● (2 1/4")	●	●	●	●	●	●	●	●	●
COMPASSO Elite	●	●	●	●	●		●	●	●	
COMPASSO Slim			●	●			●			
C <sup>2</sup> Paired COMPASSO Channels		●	●	●				●	●	●

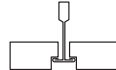
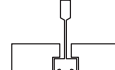
Grid Profile Options	DX®/DXL™	DXW™	CENTRICITEE™ DXT	DX®/DXL™	CENTRICITEE™ DXLT	FINELINE®	DX®/DXL™ Concealed
							
COMPASSO Standard	●	●	●	●	●	●	●
COMPASSO Elite	●	●	●	●	●	●	
COMPASSO Slim	●	●	●	●	●	●	

Recommended Applications	CELEBRATION®	True® Wood Linear	True® Wood Panels (Including AR)	PARALINE®	Drywall	Open Cell GridWARE™
	COMPASSO Standard	●**			●	●
COMPASSO Elite	●**					
COMPASSO Slim	●**					
True Wood Trim*		●	●			

\*Refer to SC 2000 for choices.

\*\*CELEBRATION panels cannot be used with 2 1/4" COMPASSO Standard or 2" COMPASSO Elite.

# System Overview

View from below

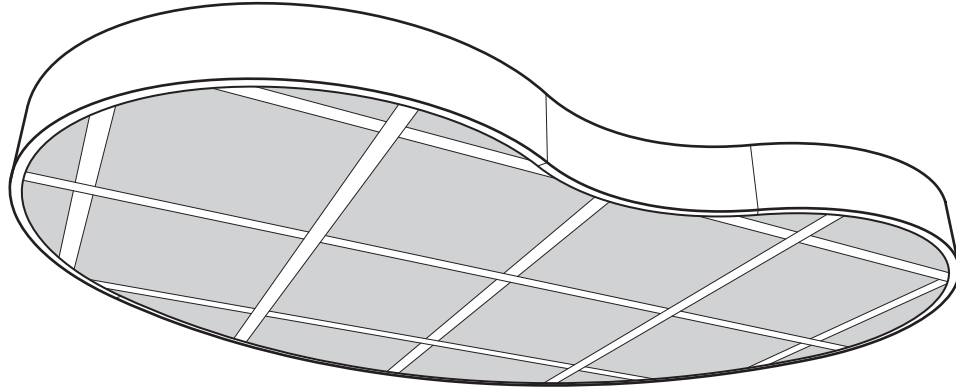

View from above

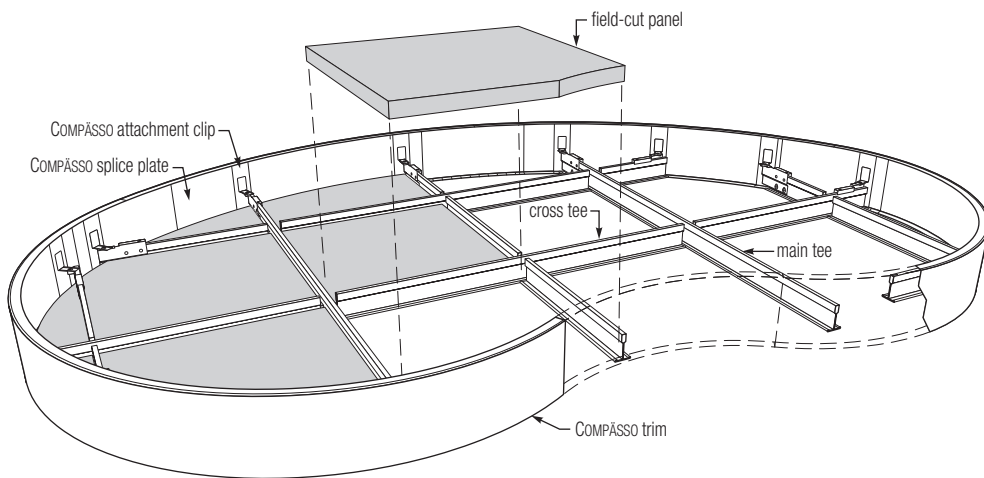

**Layout Example**

**Custom-shaped Ceiling Island**

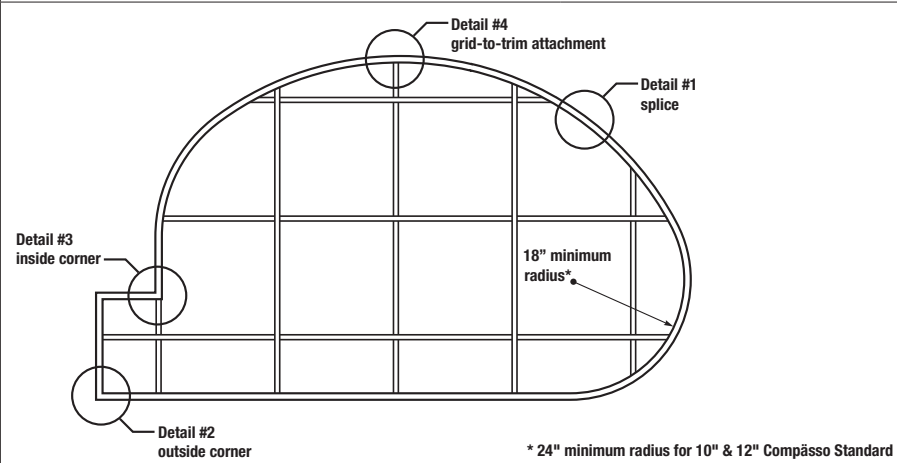

\* 24" minimum radius for 10" & 12" Compasso Standard

**Details**

**Detail No. 1—Curved Splice**

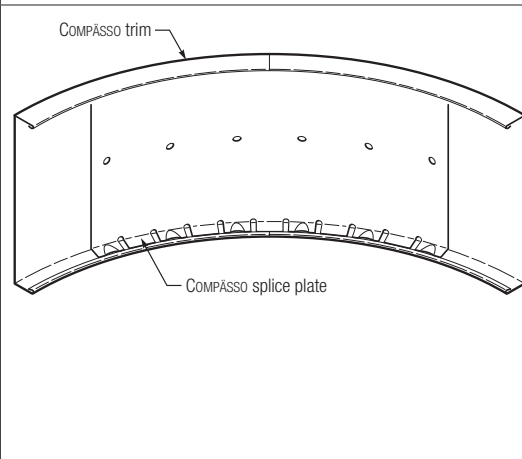

**Detail No. 2—Corner to Straight/Curved Splice**

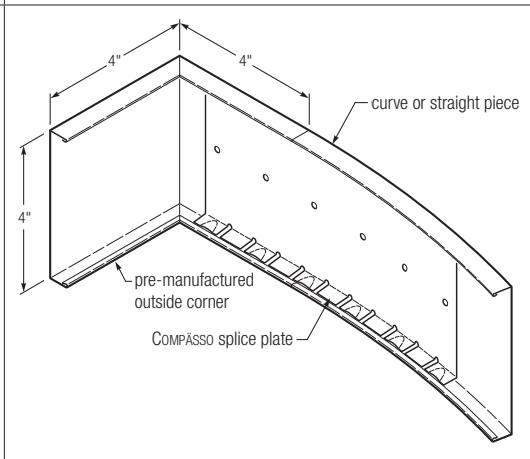

**Detail No. 3—Inside Corner**

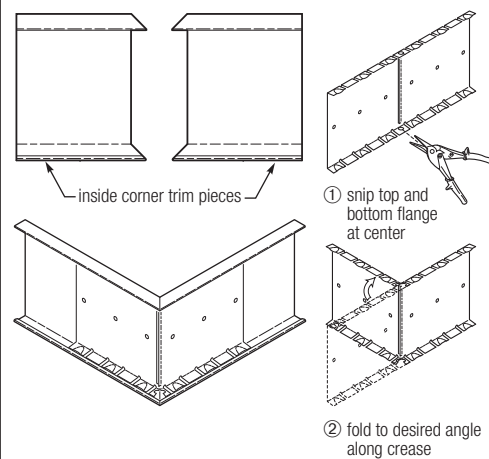

**Detail No. 4—Grid to Trim Attachment**

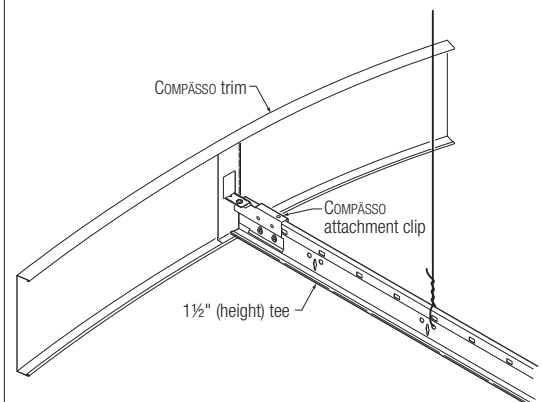

# Applications

**Layout Example**

**On-Module Ceiling Island**

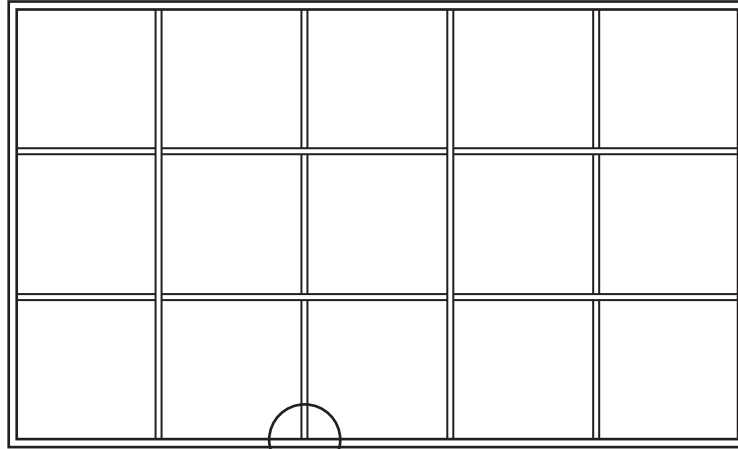

Detail #1 — Detail #1A

**Details**

**Detail No. 1—Edge Detail Capping Suspension Tee**

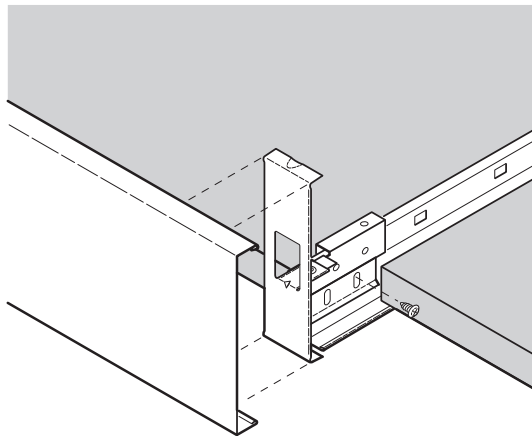

**Detail No. 1—Section**

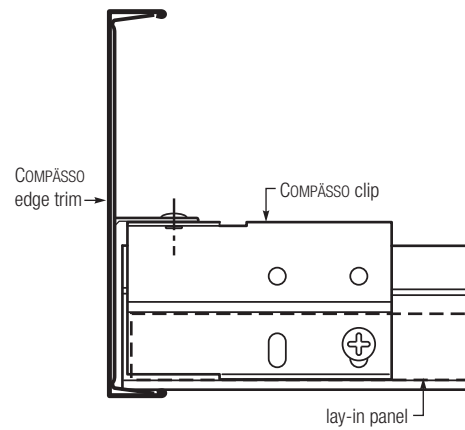

**Detail No. 1A—Edge Detail Parallel to Suspension Tee**

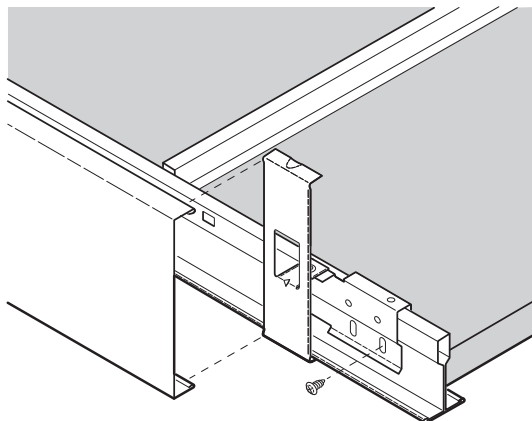

**Detail No. 1A—Section**

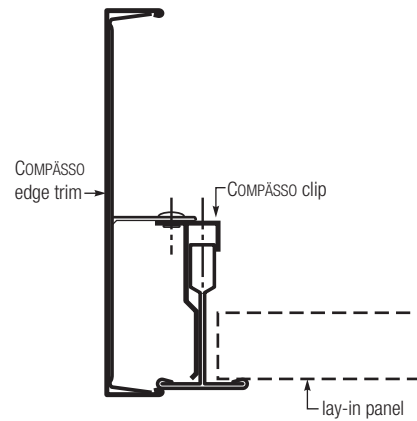

# Components

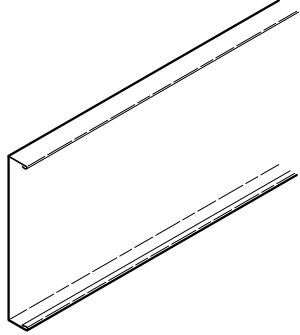
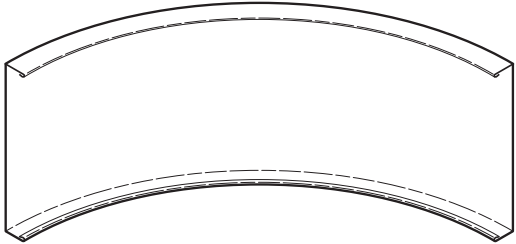
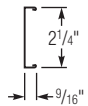
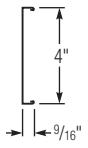
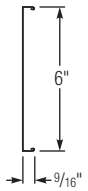
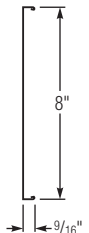
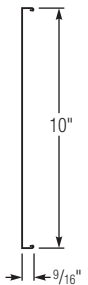
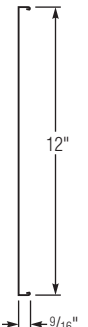
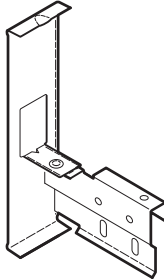
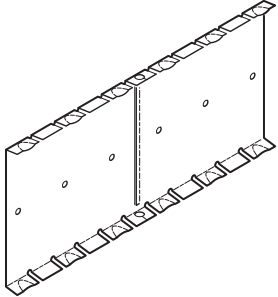
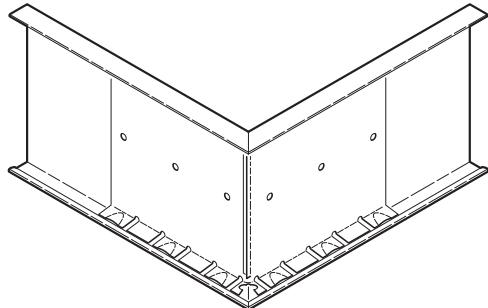
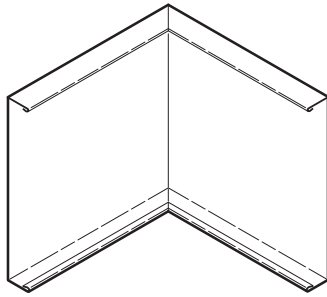
<b>Trim Construction</b>	<b>Straight</b> 		<b>Curved</b> <p>18" minimum radius (24" minimum radius for 10" &amp; 12" trim)</p> 			
<b>Trim Sizes</b>	<b>Section Views</b>					
	<b>2-1/4"</b> 	<b>4"</b> 	<b>6"</b> 	<b>8"</b> 	<b>10"</b> 	<b>12"</b> 
<b>Accessories</b>	<b>Attachment Clip</b> 			<b>Splice</b> 		
	<b>Inside Corner</b> 			<b>Outside Corner</b> 		

# System Overview

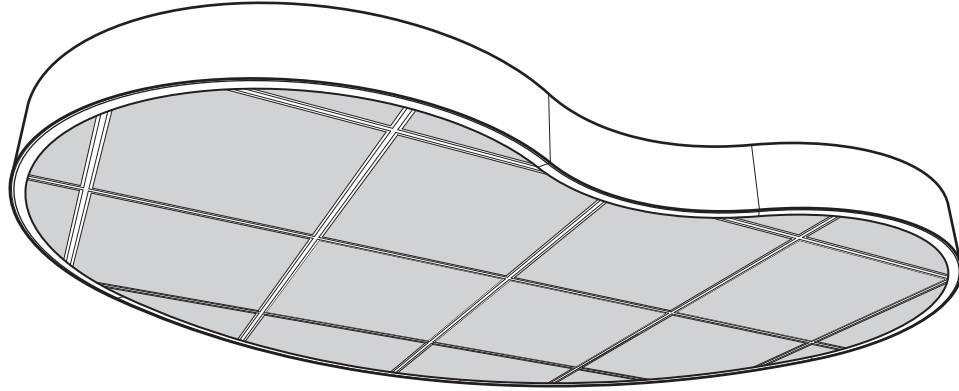

View from Below

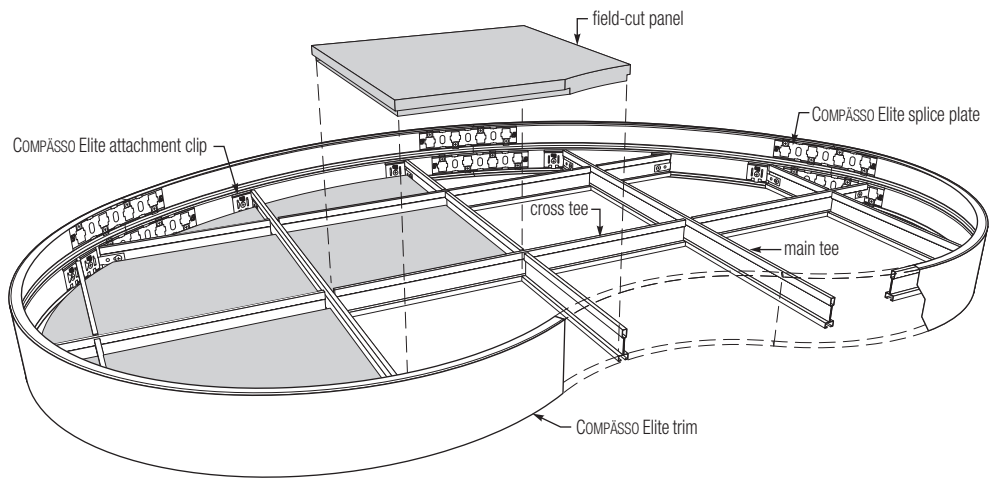

View from Above

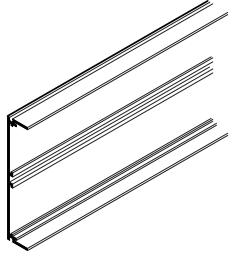
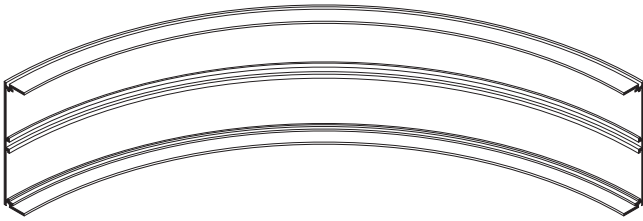
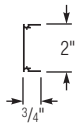
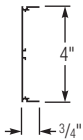
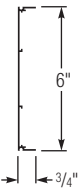

# Components

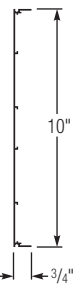
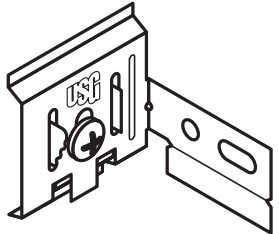
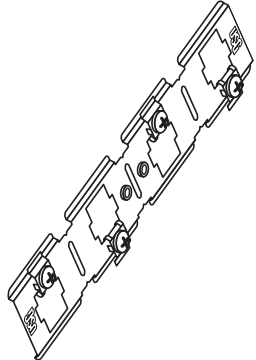
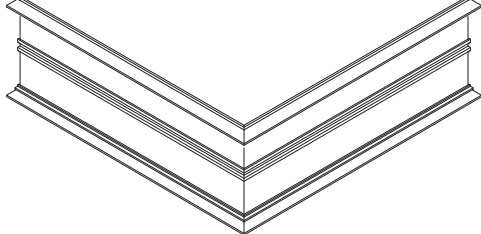
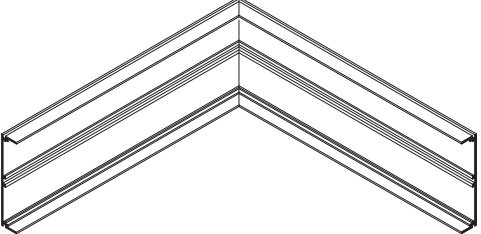
<b>Trim Construction</b>	<b>Straight</b> 	<b>Curved</b> 				
<b>Trim Sizes</b>	<b>Section Views</b>					
	<b>2"</b> 	<b>4"</b> 	<b>6"</b> 	<b>8"</b> 	<b>10"</b> 	
<b>Accessories</b>	<b>Attachment Clip</b> 		<b>Splice Plate</b> 			
	<b>Inside Corner</b> 		<b>Outside Corner</b> 			

# Applications

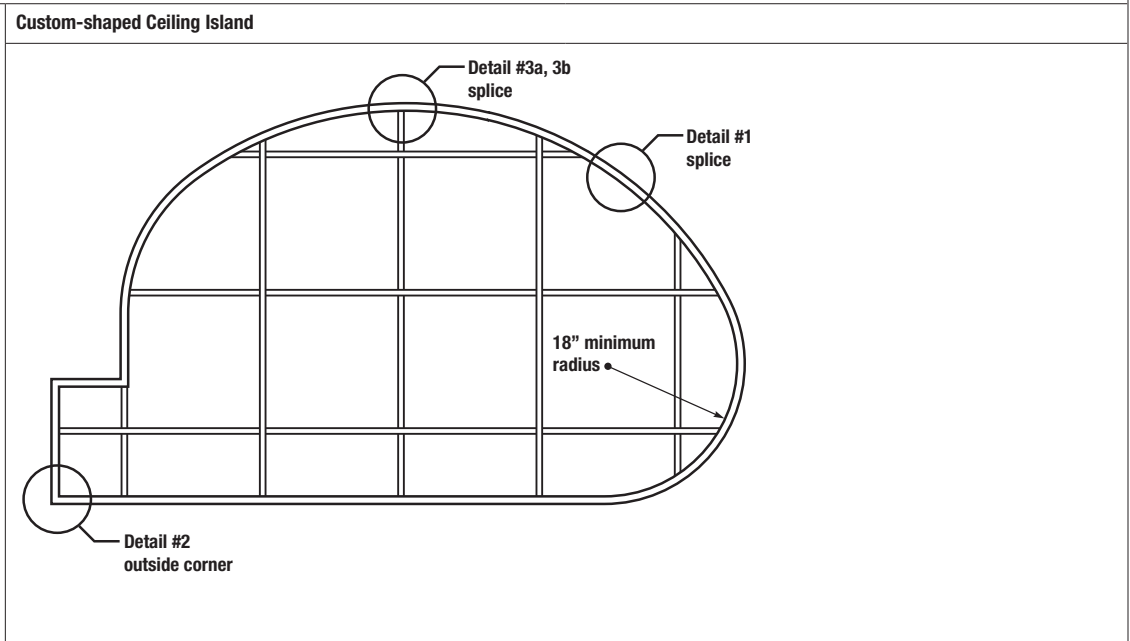
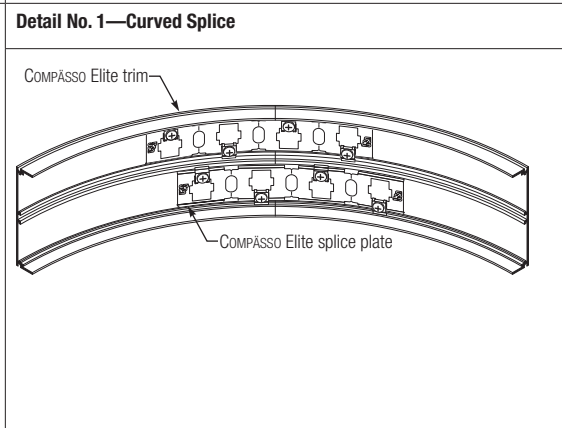
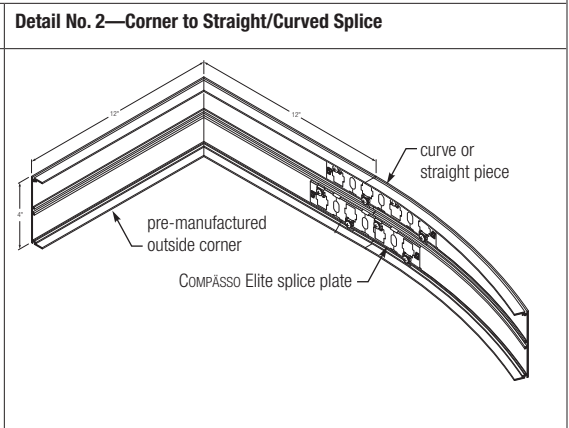
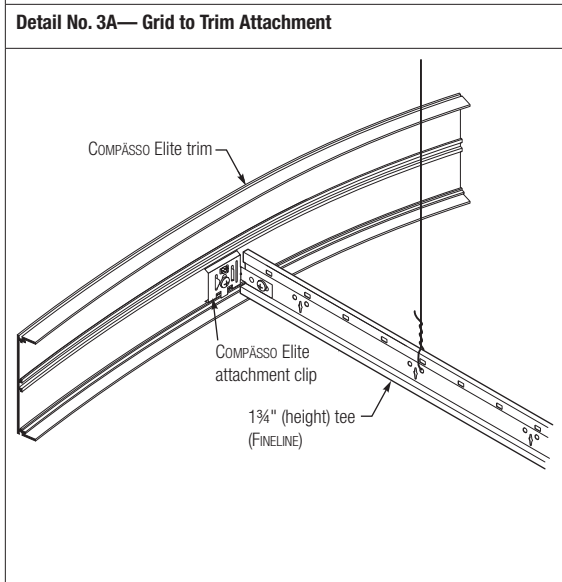
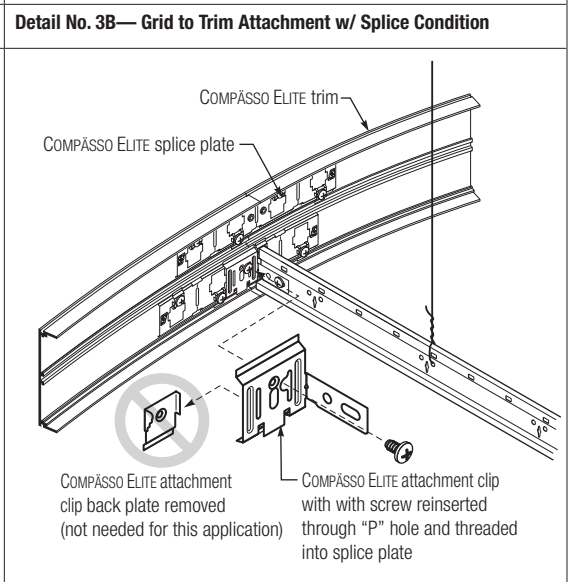
<p><b>Layout Example</b></p>	<p><b>Custom-shaped Ceiling Island</b></p> 	
<p><b>Details</b></p>	<p><b>Detail No. 1—Curved Splice</b></p> 	<p><b>Detail No. 2—Corner to Straight/Curved Splice</b></p> 
<p><b>Detail No. 3A— Grid to Trim Attachment</b></p> 	<p><b>Detail No. 3B— Grid to Trim Attachment w/ Splice Condition</b></p> 	

# Installation Details

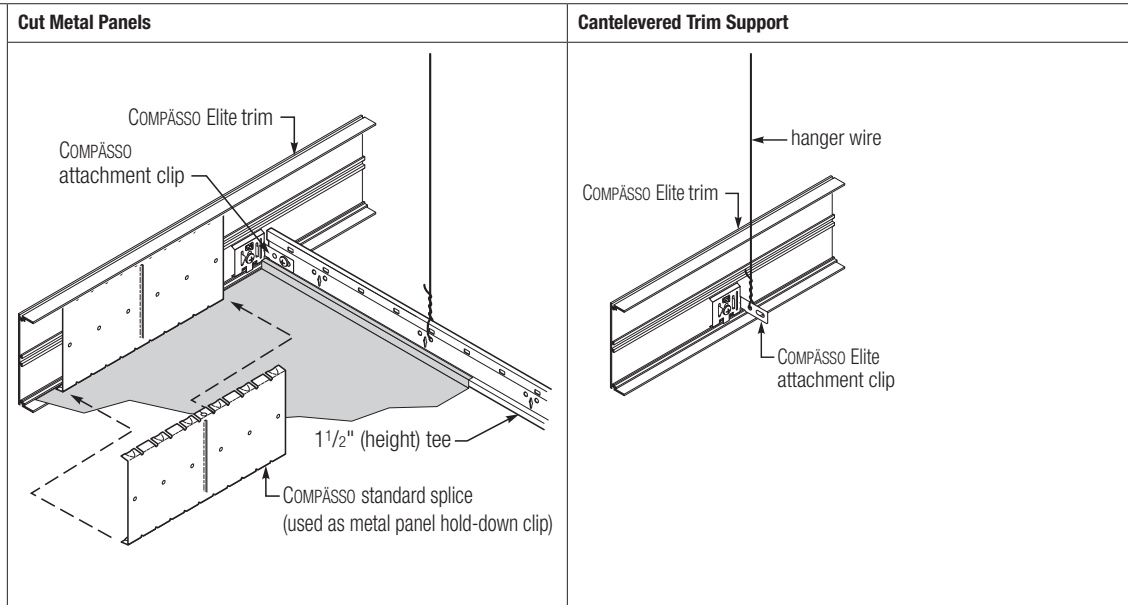

# System Overview

View from Below

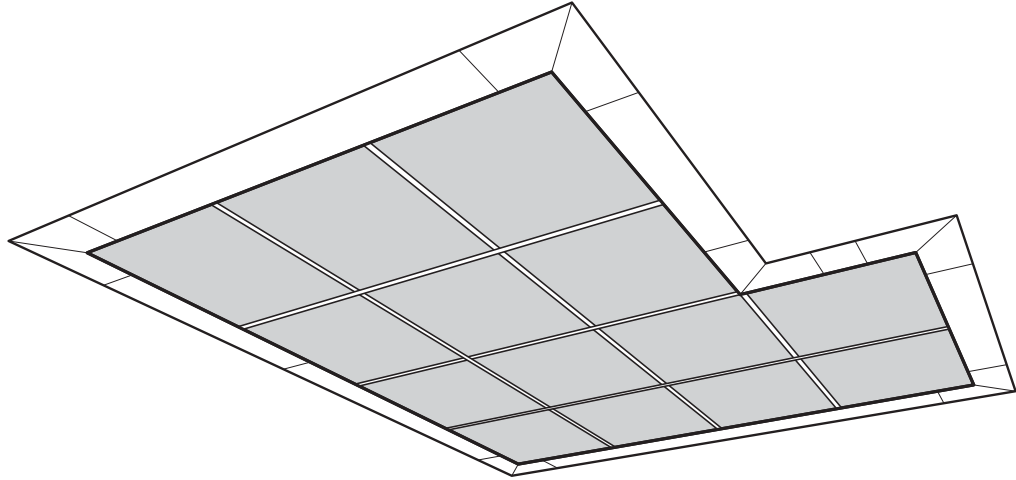

View from Above

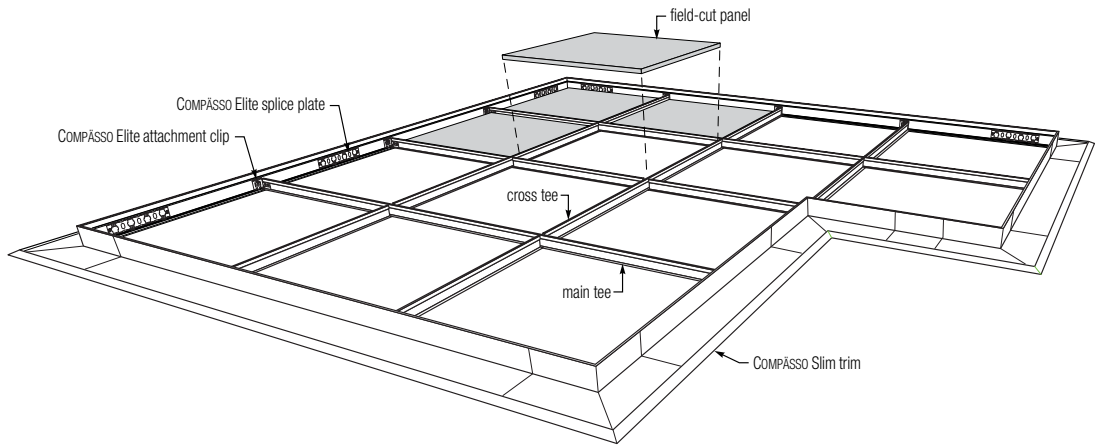

# Components

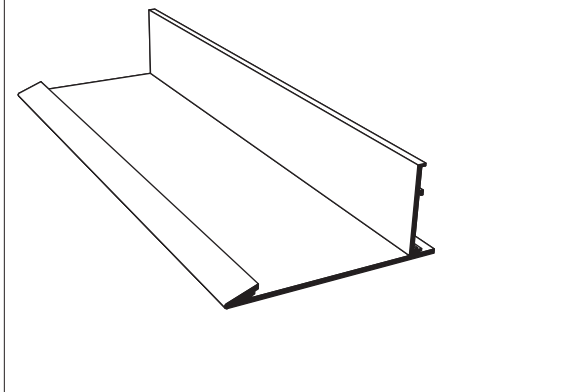
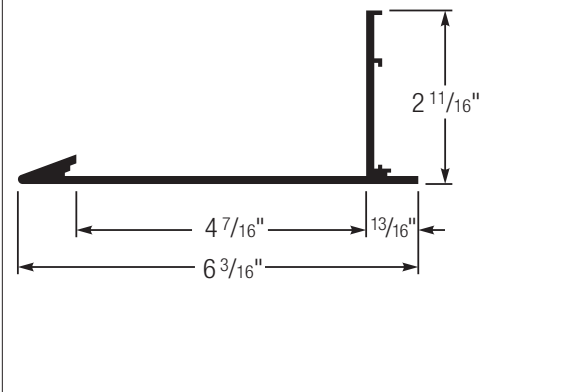
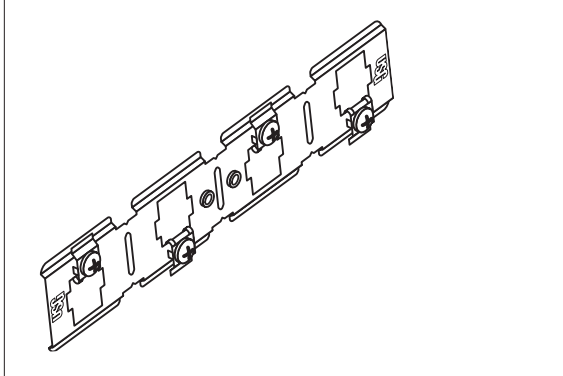
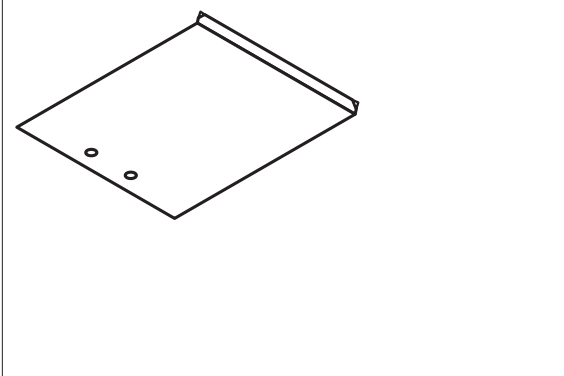
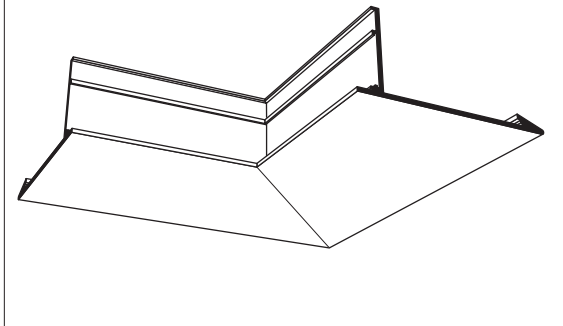
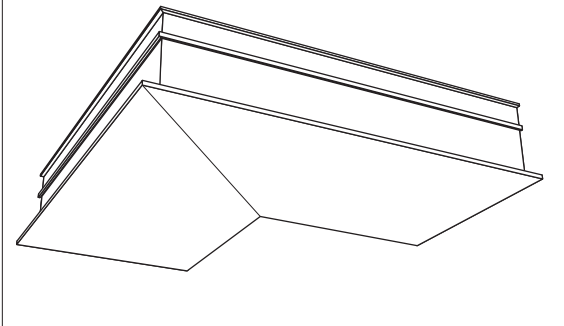
<b>Trim Construction</b>	<b>Perspective</b> 	<b>Section</b> 
<b>Accessories</b>	<b>Splice</b> 	<b>Alignment Plate</b> 
	<b>Inside Corner</b> 	<b>Outside Corner</b> 

# Applications

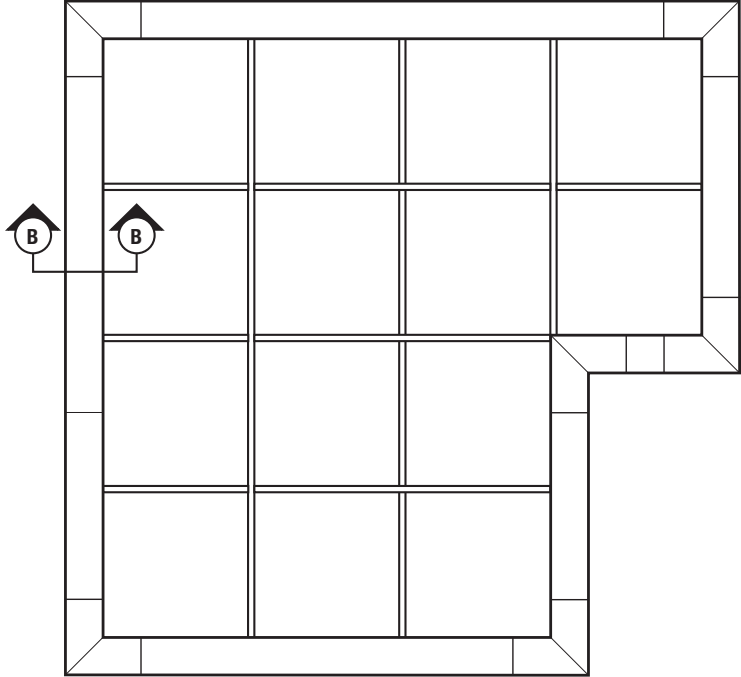
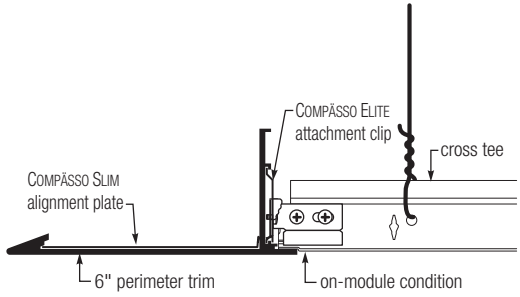
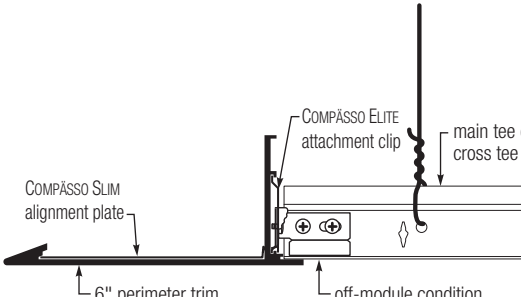
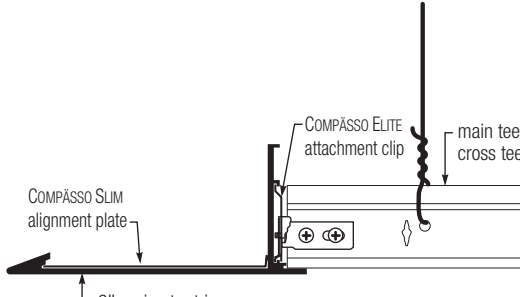
<p><b>Layout Example</b></p>	<p><b>Custom-shaped Ceiling Island</b></p> 	
<p><b>Details</b></p>	<p><b>Detail B-B— Full Module at Perimeter</b></p>  <p>COMPASSO SLIM alignment plate</p> <p>6" perimeter trim</p> <p>COMPASSO ELITE attachment clip</p> <p>cross tee</p> <p>on-module condition</p>	<p><b>Detail B-B— Fineline Grid</b></p>  <p>COMPASSO SLIM alignment plate</p> <p>6" perimeter trim</p> <p>COMPASSO ELITE attachment clip</p> <p>main tee or cross tee</p> <p>off-module condition</p>
	<p><b>Detail B-B— Cut Module at Perimeter</b></p>  <p>COMPASSO SLIM alignment plate</p> <p>6" perimeter trim</p> <p>COMPASSO ELITE attachment clip</p> <p>main tee or cross tee</p>	

# Additional Application Details

## Elevation Transition

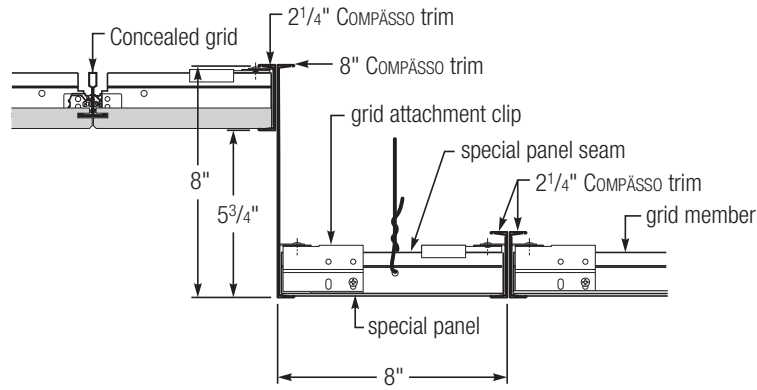

## Light Cove with Reflector

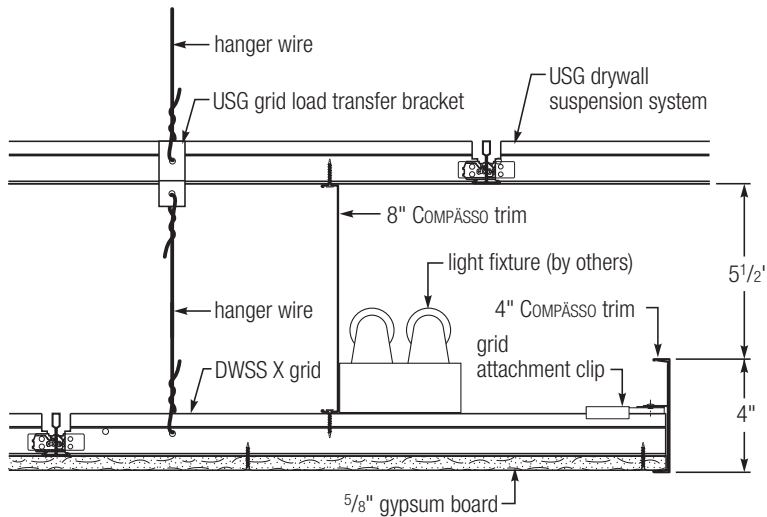

**Note:** Drywall solution only available with COMPASSO Standard.

# Additional Application Details

## Light Cove

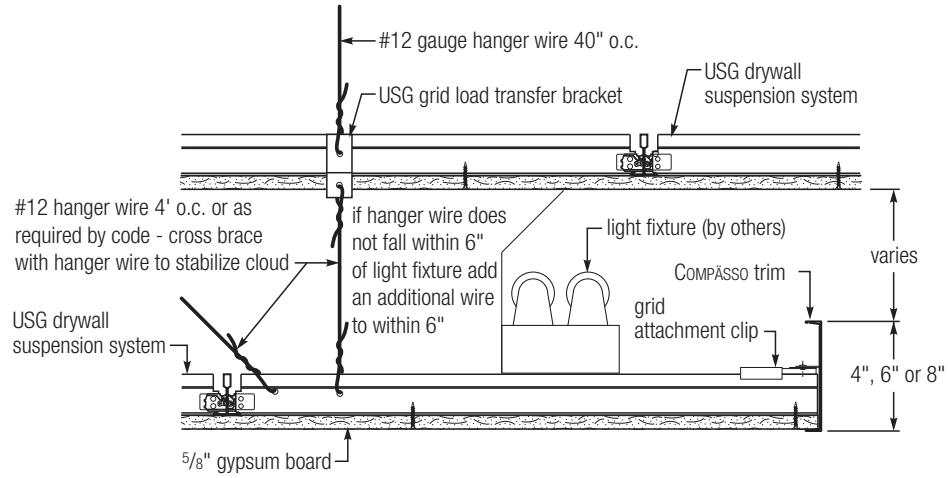

## Light Cove with Closure

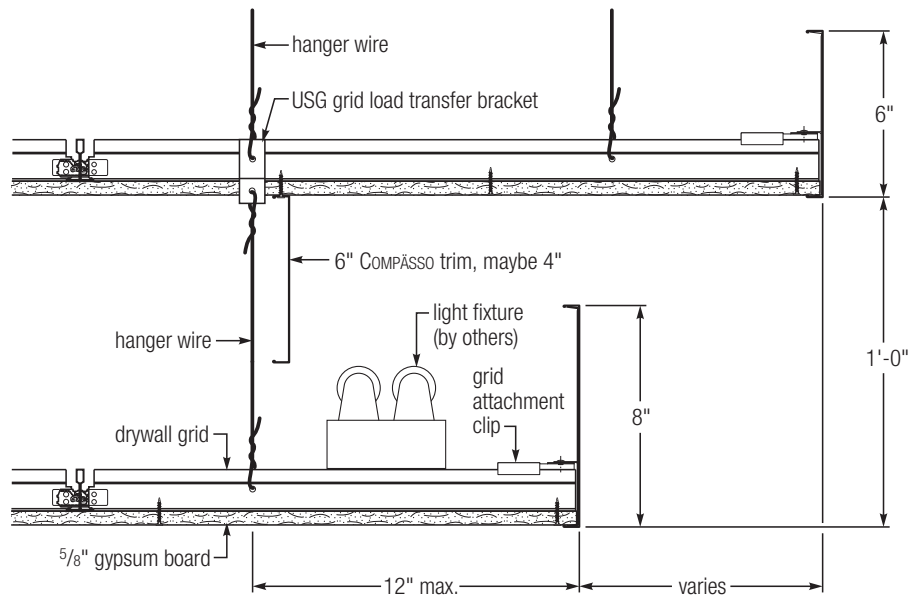

**Note:** Drywall solution only available with COMPASSO Standard.

# Typical Installation Shop Drawing

## Typical Shop Drawing — Engineered COMPASSO

4" COMPASSO  
050 white 360 paint  
GWDX grid

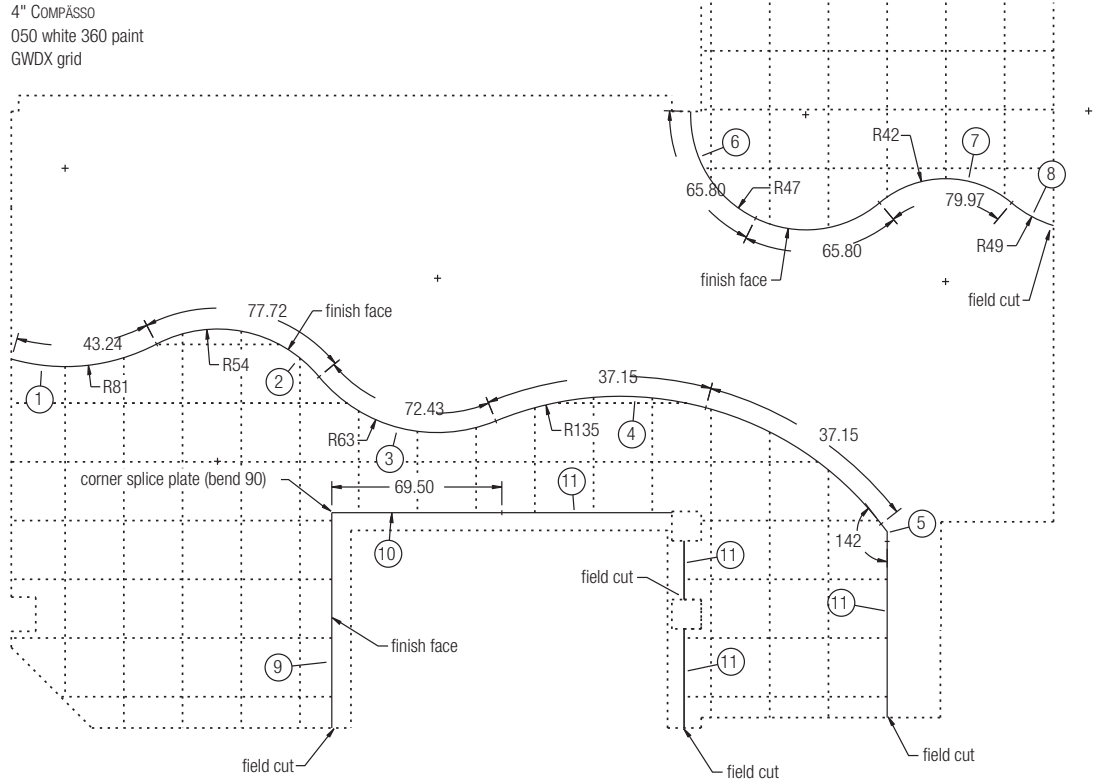

Area 1 COMPASSO Plan  
scale 1/4" = 1'-0"  
74.2 lin. ft.  
36.08% straight COMPASSO

Berry College Krannert SE0-0915  
3-9-01 sheet 3 of 4

# Application Guide

## Architectural Specifications

Note to specifier: The following specification for the COMPASSO Standard suspension trim system is a guide in the preparation of a project specification for an interior nonfire-rated trimmed ceiling island or fascia. Delete such items that are not related to the particular project. Where blank spaces occur, provide information incidental to the particular project for which the specification is prepared.

The International System of Units (Metric Units) is available on request.

Section 13 \_\_\_\_\_.

**Part 1:  
General**

**1.01  
Description of Work**

- A.** Related work specified elsewhere:
  - 1.** Insulation: Section \_\_\_\_\_.
  - 2.** Mechanical equipment: Section \_\_\_\_\_.
  - 3.** Electrical: Section \_\_\_\_\_.
  - 4.** Gypsum board systems: Section \_\_\_\_\_.
  - 5.** Acoustical ceilings: Section \_\_\_\_\_.
- B.** Work installed but furnished under other sections: \_\_\_\_\_.
- C.** Work furnished but installed under other sections: \_\_\_\_\_.

**1.02  
System Description**

- A.** Edge trim system for suspended ceiling system, consisting of (2-1/4" x 9/16") (4" x 9/16") (6" x 9/16") (8" x 9/16") (10" x 9/16") (12" x 9/16") metal pans curved to inside and outside radii per drawing supplied by architect. Attachment to grid system is provided by a specially designed COMPASSO Standard attachment clip, which snaps into and locks against hems of COMPASSO trim and is screw-attached to the bulb of the intersecting DOWN suspension system member. Independent sections of trim are joined together using the COMPASSO Standard splice plate.

**1.03  
Quality Assurance**

- A.** Subcontractor qualifications: Installer shall have not less than three years of successful experience in the installation of ceiling systems on projects with requirements similar to requirements specified.
- B.** Requirements of regulatory agencies: Codes and regulations of authorities having jurisdiction.
- C.** Source quality control:
  - 1.** Test reports: Manufacturer will provide test certification for minimum requirements as tested in accordance with applicable industry standards and/or to meet performance standards specified by various agencies.
  - 2.** Changes from system: System performance following any substitution of materials or change in assembly design must be certified by the manufacturer.

**1.04  
References**

- A.** ASTM C635: Standard specifications for metal suspension systems for acoustical tile and lay-in panel ceilings.
- B.** ASTM C636: Recommended practice for installation of metal suspension systems for acoustical tile and lay-in panel ceilings.
- C.** CISCA Ceiling Systems Installation Handbook.

**1.05  
Submittals**

- A.** Samples: Submit representative sample of color and finish of all exposed materials.
- B.** Shop drawings:
  - 1.** Reflected ceiling plans: Indicate layout arrangement of ceiling design, dimensions and locations of related integrated lighting and air distribution components.
  - 2.** Installation drawings: Detail complete installation including all trim pieces, attachment clips, splice plates and corner pieces, installation of related lighting and air distribution components, access requirements, and sound absorption requirements.
  - 3.** Manufacturer's data: Submit manufacturer's catalog cuts or standard drawings showing details of system with project conditions clearly identified and manufacturer's recommended installation instructions.
  - 4.** Maintenance materials: Submit one percent of amount of ceiling components installed.

	<b>1.06 Delivery, Storage and Handling</b>	<ul style="list-style-type: none"> <li>A. Delivery of materials: Deliver materials in original, unopened packages clearly labeled with the manufacturer's name and identification numbers.</li> <li>B. Inspection: Promptly inspect delivered materials, file freight claims for damage during shipment, and order replacement material, as required.</li> <li>C. Storage: Store in manner that will prevent warpage, scratches or damage of any kind.</li> <li>D. Handling: Handle in such a manner as to ensure against racking, distortion or physical damage of any kind.</li> </ul>
	<b>1.07 Project Conditions</b>	<ul style="list-style-type: none"> <li>A. Existing conditions: (Include specific alteration work requirements for project.)</li> <li>B. Environmental requirements: Building shall be enclosed with windows and exterior doors in place and glazed, and roof watertight before installation of ceiling system and related ceiling components. Climactic condition range of 60 °F (15.56 °C) to 85 °F (29.44 °C); relative humidity not more than 70%.</li> <li>C. Coordination with other work: <ul style="list-style-type: none"> <li>1. Mechanical work: Ductwork above ceiling shall be complete, and permanent heating and cooling systems operating to climate conditions prior to installation of ceiling components.</li> <li>2. Electrical work: Installation of conduit above ceiling shall be complete before installation of ceiling components.</li> <li>3. Fire protection work: Fire protection lines and/or equipment occurring above ceiling shall be completed and tested before ceiling components are installed.</li> </ul> </li> <li>D. Protection: Protect completed work above ceiling system from damage during installation of ceiling components.</li> </ul>
<b>Part 2: Products</b>	<b>2.01 Manufacturer</b>	COMPASSO Standard suspension trim for use with any standard DONN® suspension system as manufactured by USG Interiors, Inc., Chicago, Illinois, U.S.A.
	<b>2.02 Materials (Delete items not applicable)</b>	<ul style="list-style-type: none"> <li>A. 2-1/4" COMPASSO Standard system <ul style="list-style-type: none"> <li>1. 2-1/4" COMPASSO Standard trim: 2-1/4" wide face, 9/16" horizontal legs with hems formed for attachment to the COMPASSO Standard mounting clip; commercial quality cold-rolled 24-gauge steel, factory finished in (baked enamel paint finish) ( ) color.</li> <li>2. Splice plate: steel in finish to match trim pans; formed for snap-fit into 2-1/4" pan ends.</li> <li>3. Attachment clips: hot-dipped galvanized steel in (galvanized finish) (finish to match pans) formed for snap-fit into 2-1/4" pan and attached to DONN (DX®) (DXW™) (CENTRICITEE™) (FINELINE®) (USG Drywall Suspension System) suspension system members.</li> <li>4. 90° corner trim pieces: to match COMPASSO trim.</li> </ul> </li> <li>B. 4" COMPASSO Standard system <ul style="list-style-type: none"> <li>1. 4" COMPASSO Standard trim: 4" wide face, 9/16" horizontal legs with hems formed for attachment to the COMPASSO Standard mounting clip; commercial quality cold-rolled 24-gauge steel, factory finished in (baked enamel paint finish) ( ) color.</li> <li>2. Splice plate: steel in finish to match trim pans; formed for snap-fit into 4" pan ends.</li> <li>3. Attachment clips: hot-dipped galvanized steel in (galvanized finish) (finish to match pans) formed for snap-fit into 4" pan and attached to DONN (DX) (DXW) (CENTRICITEE) (FINELINE) (USG Drywall Suspension System) suspension system members.</li> <li>4. 90° corner trim pieces: to match COMPASSO Standard trim.</li> </ul> </li> </ul>

# Application Guide

## Architectural Specifications

- C. 6" COMPASSO Standard system
  - 1. 6" COMPASSO Standard trim: 6" wide face, 9/16" horizontal legs with hems formed for attachment to the COMPASSO Standard mounting clip; commercial quality cold-rolled 24-gauge steel, factory finished in (baked enamel paint finish) ( ) color.
  - 2. Splice plate: steel in finish to match trim pans; formed for snap-fit into 6" pan ends.
  - 3. Attachment clips: hot-dipped galvanized steel in (galvanized finish) (finish to match pans) formed for snap-fit into 6" pan and attached to DONN (DX) (DXW) (CENTRICITEE) (FINELINE) (USG Drywall Suspension System) suspension system members.
  - 4. 90° corner trim pieces: to match COMPASSO Standard trim.
- D. 8" COMPASSO Standard system
  - 1. 8" COMPASSO Standard trim: 8" wide face, 9/16" horizontal legs with hems formed for attachment to the COMPASSO Standard mounting clip; commercial quality cold-rolled 24-gauge steel, factory finished in (baked enamel paint finish) ( ) color.
  - 2. Splice plate: steel in finish to match trim pans; formed for snap-fit into 8" pan ends.
  - 3. Attachment clips: hot-dipped galvanized steel in (galvanized finish) (finish to match pans) formed for snap-fit into 8" pan and attached to DONN (DX) (DXW) (CENTRICITEE) (FINELINE) (USG Drywall Suspension System) suspension system members.
  - 4. 90° corner trim pieces: to match COMPASSO Standard trim.
- E. 10" COMPASSO Standard system
  - 1. 10" COMPASSO Standard trim: 10" wide face, 9/16" horizontal legs with hems formed for attachment to the COMPASSO mounting clip; aluminum, factory finished in (baked enamel paint finish) ( ) color.
  - 2. Splice plate: steel in finish to match trim pans; formed for snap-fit into 10" pan ends.
  - 3. Attachment clips: hot-dipped galvanized steel in (galvanized finish) (finish to match pans) formed for snap-fit into 10" pan and attached to DONN (DX) (DXW) (CENTRICITEE) (FINELINE) (USG Drywall Suspension System) suspension system members.
  - 4. 90° corner trim pieces: to match COMPASSO Standard trim.
- F. 12" COMPASSO Standard system
  - 1. 12" COMPASSO Standard trim: 12" wide face, 9/16" horizontal legs with hems formed for attachment to the COMPASSO Standard mounting clip; aluminum, factory finished in (baked enamel paint finish) ( ) color.
  - 2. Splice plate: steel in finish to match trim pans; formed for snap-fit into 12" pan ends.
  - 3. Attachment clips: hot-dipped galvanized steel in (galvanized finish) (finish to match pans) formed for snap-fit into 12" pan and attached to DONN (DX) (DXW) (CENTRICITEE) (FINELINE) (USG Drywall Suspension System) suspension system members.
  - 4. 90° corner trim pieces: to match COMPASSO Standard trim.
- G. For specific project details and bill of materials see USG Interiors Drawing No. RTQ - \_\_\_\_\_ (provided by USG Interiors sales representative).

### 2.03 Fabrication

- A. Trim pans: Edges formed to snap onto attachment clips and provide positive mechanical lock with no visible fasteners. Factory finished to match approved samples.
- B. Splice plates: Formed to snap into and provide positive lock between abutting pans with no visible fasteners. Factory finished to match trim pans.
- C. Mounting clips: Formed to snap into trim pans and provide positive mechanical lock with no visible fasteners while providing a variable angle, screw-fastened connection to suspension members which intersect the trim.

**Part 3:  
Execution**

**3.01  
Inspection**

- A. Examine areas to receive trim system for conditions which will adversely affect installation.
- B. Do not start work until unsatisfactory conditions are corrected.
- C. Work to be concealed: Verify work above support system is complete, tested, and installed in manner which will not affect layout and installation of ceiling system.
- D. Fire-rated assembly: Construction above ceiling system shall meet requirements as applicable to provide fire-resistance rating specified.

**3.02  
Preparation**

- A. Field dimensions: Installer must verify actual field dimensions prior to installation.
- B. Renovation work: Installing contractor shall verify that existing ceiling structure is adequate to support additional COMPASSO Standard ceiling suspension requirement.
- C. Coordination: Coordinate and schedule installation of ceiling system with work of other trades affected by this installation, with particular attention given to mechanical and electrical work required to be installed and operating before ceiling work can begin.

**3.03  
Installation**

- A. Reference: Install in accordance with approved shop drawings and manufacturer's instructions. Follow architects' details for thermal and building expansion joint treatments.
- B. Hanger wires:
  - 1. Spacing: Space hanger wires maximum 48" o.c. along length of carrier system, attached directly to structure above.
  - 2. Limitation: Do not support hanger wires from mechanical and/or electrical equipment, piping, or other equipment occurring above ceiling.
  - 3. Provide additional fixture support as required in accordance with local building codes or other regulatory agencies.
- C. COMPASSO Standard system: Install according to procedure provided by manufacturer and in accordance with approved shop drawings.
  - 1. Perimeter connection detail (recommended) (optional).
- D. Lighting components: Refer to Section 16 \_\_\_\_\_.
- E. Air distribution components: Refer to Section 15 \_\_\_\_\_.

**3.04  
Field Quality  
Control**

- A. Deflection on installed system: Maximum deflection shall not exceed 1/360 of the span.

# Application Guide

## Architectural Specifications

Note to specifier: The following specification for the COMPASSO Elite suspension trim system is a guide in the preparation of a project specification for an interior nonfire-rated trimmed ceiling island or fascia. Delete such items that are not related to the particular project. Where blank spaces occur, provide information incidental to the particular project for which the specification is prepared.

The International System of Units (Metric Units) is available on request.

Section 13 \_\_\_\_\_.

**Part 1:  
General**

**1.01  
Description of Work**

- A.** Related work specified elsewhere:
  - 1.** Insulation: Section \_\_\_\_\_.
  - 2.** Mechanical equipment: Section \_\_\_\_\_.
  - 3.** Electrical: Section \_\_\_\_\_.
  - 4.** Gypsum board systems: Section \_\_\_\_\_.
  - 5.** Acoustical ceilings: Section \_\_\_\_\_.
- B.** Work installed but furnished under other sections: \_\_\_\_\_.
- C.** Work furnished but installed under other sections: \_\_\_\_\_.

**1.02  
System Description**

- A.** Edge trim system for suspended ceiling system, consisting of (2" x 3/4") (4" x 3/4") (6" x 3/4") (8" x 3/4") (10" x 3/4") metal pans curved to inside and outside radii per drawing supplied by architect. Attachment to grid system is provided by a specially designed COMPASSO Elite attachment clip, which screw attaches to and locks against the bosses of COMPASSO Elite trim and is screw-attached to the bulb of the intersecting DOWN suspension system member. Independent sections of trim are joined together using the COMPASSO Elite splice plate.

**1.03  
Quality Assurance**

- A.** Subcontractor qualifications: Installer shall have not less than three years of successful experience in the installation of ceiling systems on projects with requirements similar to requirements specified.
- B.** Requirements of regulatory agencies: Codes and regulations of authorities having jurisdiction.
- C.** Source quality control:
  - 1.** Test reports: Manufacturer will provide test certification for minimum requirements as tested in accordance with applicable industry standards and/or to meet performance standards specified by various agencies.
  - 2.** Changes from system: System performance following any substitution of materials or change in assembly design must be certified by the manufacturer.

**1.04  
References**

- A.** ASTM C635: Standard specifications for metal suspension systems for acoustical tile and lay-in panel ceilings.
- B.** ASTM C636: Recommended practice for installation of metal suspension systems for acoustical tile and lay-in panel ceilings.
- C.** CISCA Ceiling Systems Installation Handbook.

**1.05  
Submittals**

- A.** Samples: Submit representative sample of color and finish of all exposed materials.
- B.** Shop drawings:
  - 1.** Reflected ceiling plans: Indicate layout arrangement of ceiling design, dimensions and locations of related integrated lighting and air distribution components.
  - 2.** Installation drawings: Detail complete installation including all trim pieces, attachment clips, splice plates and corner pieces, installation of related lighting and air distribution components, access requirements, and sound absorption requirements.
  - 3.** Manufacturer's data: Submit manufacturer's catalog cuts or standard drawings showing details of system with project conditions clearly identified and manufacturer's recommended installation instructions.
  - 4.** Maintenance materials: Submit one percent of amount of ceiling components installed.

<b>1.06 Delivery, Storage and Handling</b>	<ul style="list-style-type: none"> <li>A. Delivery of materials: Deliver materials in original, unopened packages clearly labeled with the manufacturer's name and identification numbers.</li> <li>B. Inspection: Promptly inspect delivered materials, file freight claims for damage during shipment, and order replacement material, as required.</li> <li>C. Storage: Store in manner that will prevent warpage, scratches or damage of any kind.</li> <li>D. Handling: Handle in such a manner as to ensure against racking, distortion or physical damage of any kind.</li> </ul>				
<b>1.07 Project Conditions</b>	<ul style="list-style-type: none"> <li>A. Existing conditions: (Include specific alteration work requirements for project.)</li> <li>B. Environmental requirements: Building shall be enclosed with windows and exterior doors in place and glazed, and roof watertight before installation of ceiling system and related ceiling components. Climactic condition range of 60 °F (15.56 °C) to 85 °F (29.44 °C); relative humidity not more than 70%.</li> <li>C. Coordination with other work: <ul style="list-style-type: none"> <li>1. Mechanical work: Ductwork above ceiling shall be complete, and permanent heating and cooling systems operating to climate conditions prior to installation of ceiling components.</li> <li>2. Electrical work: Installation of conduit above ceiling shall be complete before installation of ceiling components.</li> <li>3. Fire protection work: Fire protection lines and/or equipment occurring above ceiling shall be completed and tested before ceiling components are installed.</li> </ul> </li> <li>D. Protection: Protect completed work above ceiling system from damage during installation of ceiling components.</li> </ul>				
<b>Part 2: Products</b>	<table border="0"> <tr> <td data-bbox="284 1050 394 1102"><b>2.01 Manufacturer</b></td> <td data-bbox="521 1050 1458 1102">COMPASSO Elite suspension trim for use with any standard DONN® suspension system as manufactured by USG Interiors, Inc., Chicago, Illinois, U.S.A.</td> </tr> <tr> <td data-bbox="284 1142 453 1209"><b>2.02 Materials (Delete items not applicable)</b></td> <td data-bbox="472 1142 1469 1602"> <ul style="list-style-type: none"> <li>A. 2" COMPASSO Elite system <ul style="list-style-type: none"> <li>1. 2" COMPASSO Elite trim: 2" wide face, 3/4" horizontal legs with bosses extruded for attachment to the COMPASSO Elite attachment clip; extruded aluminum, factory powder coated. ( ) color.</li> <li>2. Splice plate: steel in finish to match trim; formed for snap-fit into 2" pan ends.</li> <li>3. Attachment clips: hot-dipped galvanized steel in (galvanized finish) (finish to match trim) formed for snap-fit into 2" trim and attached to DONN (DX®) (DXW™) (CENTRICITEE™) (FINELINE®) (USG Drywall Suspension System) suspension system members.</li> <li>4. 90° corner trim pieces: to match COMPASSO Elite trim.</li> </ul> </li> <li>B. 4" COMPASSO Elite system <ul style="list-style-type: none"> <li>1. 4" COMPASSO Elite trim: 4" wide face, 3/4" horizontal legs with bosses extruded for attachment to the COMPASSO Elite attachment clip; extruded aluminum, factory powder coated. ( ) color.</li> <li>2. Splice plate: steel in finish to match trim; formed for snap-fit into 4" pan ends.</li> <li>3. Attachment clips: hot-dipped galvanized steel in (galvanized finish) (finish to match pans) formed for snap-fit into 4" trim and attached to DONN (DX) (DXW) (CENTRICITEE) (FINELINE) (USG Drywall Suspension System) suspension system members.</li> <li>4. 90° corner trim pieces: to match COMPASSO Elite trim.</li> </ul> </li> </ul> </td> </tr> </table>	<b>2.01 Manufacturer</b>	COMPASSO Elite suspension trim for use with any standard DONN® suspension system as manufactured by USG Interiors, Inc., Chicago, Illinois, U.S.A.	<b>2.02 Materials (Delete items not applicable)</b>	<ul style="list-style-type: none"> <li>A. 2" COMPASSO Elite system <ul style="list-style-type: none"> <li>1. 2" COMPASSO Elite trim: 2" wide face, 3/4" horizontal legs with bosses extruded for attachment to the COMPASSO Elite attachment clip; extruded aluminum, factory powder coated. ( ) color.</li> <li>2. Splice plate: steel in finish to match trim; formed for snap-fit into 2" pan ends.</li> <li>3. Attachment clips: hot-dipped galvanized steel in (galvanized finish) (finish to match trim) formed for snap-fit into 2" trim and attached to DONN (DX®) (DXW™) (CENTRICITEE™) (FINELINE®) (USG Drywall Suspension System) suspension system members.</li> <li>4. 90° corner trim pieces: to match COMPASSO Elite trim.</li> </ul> </li> <li>B. 4" COMPASSO Elite system <ul style="list-style-type: none"> <li>1. 4" COMPASSO Elite trim: 4" wide face, 3/4" horizontal legs with bosses extruded for attachment to the COMPASSO Elite attachment clip; extruded aluminum, factory powder coated. ( ) color.</li> <li>2. Splice plate: steel in finish to match trim; formed for snap-fit into 4" pan ends.</li> <li>3. Attachment clips: hot-dipped galvanized steel in (galvanized finish) (finish to match pans) formed for snap-fit into 4" trim and attached to DONN (DX) (DXW) (CENTRICITEE) (FINELINE) (USG Drywall Suspension System) suspension system members.</li> <li>4. 90° corner trim pieces: to match COMPASSO Elite trim.</li> </ul> </li> </ul>
<b>2.01 Manufacturer</b>	COMPASSO Elite suspension trim for use with any standard DONN® suspension system as manufactured by USG Interiors, Inc., Chicago, Illinois, U.S.A.				
<b>2.02 Materials (Delete items not applicable)</b>	<ul style="list-style-type: none"> <li>A. 2" COMPASSO Elite system <ul style="list-style-type: none"> <li>1. 2" COMPASSO Elite trim: 2" wide face, 3/4" horizontal legs with bosses extruded for attachment to the COMPASSO Elite attachment clip; extruded aluminum, factory powder coated. ( ) color.</li> <li>2. Splice plate: steel in finish to match trim; formed for snap-fit into 2" pan ends.</li> <li>3. Attachment clips: hot-dipped galvanized steel in (galvanized finish) (finish to match trim) formed for snap-fit into 2" trim and attached to DONN (DX®) (DXW™) (CENTRICITEE™) (FINELINE®) (USG Drywall Suspension System) suspension system members.</li> <li>4. 90° corner trim pieces: to match COMPASSO Elite trim.</li> </ul> </li> <li>B. 4" COMPASSO Elite system <ul style="list-style-type: none"> <li>1. 4" COMPASSO Elite trim: 4" wide face, 3/4" horizontal legs with bosses extruded for attachment to the COMPASSO Elite attachment clip; extruded aluminum, factory powder coated. ( ) color.</li> <li>2. Splice plate: steel in finish to match trim; formed for snap-fit into 4" pan ends.</li> <li>3. Attachment clips: hot-dipped galvanized steel in (galvanized finish) (finish to match pans) formed for snap-fit into 4" trim and attached to DONN (DX) (DXW) (CENTRICITEE) (FINELINE) (USG Drywall Suspension System) suspension system members.</li> <li>4. 90° corner trim pieces: to match COMPASSO Elite trim.</li> </ul> </li> </ul>				

# Application Guide

## Architectural Specifications

- C.** 6" COMPASSO Elite system
  - 1. 6" COMPASSO Elite trim: 6" wide face, 3/4" horizontal legs with bosses extruded for attachment to the COMPASSO Elite attachment clip; extruded aluminum, factory powder coated. ( ) color.
  - 2. Splice plate: steel in finish to match trim pans; formed for snap-fit into 6" pan ends.
  - 3. Attachment clips: hot-dipped galvanized steel in (galvanized finish) (finish to match pans) formed for snap-fit into 6" trim and attached to DONN (DX) (DXW) (CENTRICITEE) (FINELINE) (USG Drywall Suspension System) suspension system members.
  - 4. 90° corner trim pieces: to match COMPASSO Elite trim.
- CI.** 8" COMPASSO Elite system
  - 1. 8" COMPASSO Elite trim: 8" wide face, 3/4" horizontal legs with bosses extruded for attachment to the COMPASSO Elite attachment clip; extruded aluminum, factory powder coated. ( ) color.
  - 2. Splice plate: steel in finish to match trim pans; formed for snap-fit into 8" pan ends.
  - 3. Attachment clips: hot-dipped galvanized steel in (galvanized finish) (finish to match pans) formed for snap-fit into 8" trim and attached to DONN (DX) (DXW) (CENTRICITEE) (FINELINE) (USG Drywall Suspension System) suspension system members.
  - 4. 90° corner trim pieces: to match COMPASSO Elite trim.
- CII.** 10" COMPASSO Elite system
  - 1. 10" COMPASSO Elite trim: 10" wide face, 3/4" horizontal legs with bosses extruded for attachment to the COMPASSO attachment clip; extruded aluminum, factory powder coated ( ) color.
  - 2. Splice plate: steel in finish to match trim pans; formed for snap-fit into 10" pan ends.
  - 3. Attachment clips: hot-dipped galvanized steel in (galvanized finish) (finish to match pans) formed for snap-fit into 10" trim and attached to DONN (DX) (DXW) (CENTRICITEE) (FINELINE) (USG Drywall Suspension System) suspension system members.
  - 4. 90° corner trim pieces: to match COMPASSO Elite trim.
- CIII.** For specific project details and bill of materials see USG Interiors Drawing No. RTQ - \_\_\_\_\_ (provided by USG Interiors sales representative).

### 2.03 Fabrication

- A.** Trim: Edges extruded to mate with attachment clips and provide positive mechanical lock with no visible fasteners. Factory finished to match approved samples.
- B.** Splice plates: Formed to screw into and provide positive lock between abutting pans with no visible fasteners. Factory finished to match trim.
- C.** Mounting clips: Formed to screw-attach to trim and provide positive mechanical lock with no visible fasteners while providing a variable angle, screw-fastened connection to suspension members which intersect the trim.

**Part 3:  
Execution**

**3.01  
Inspection**

- A. Examine areas to receive trim system for conditions which will adversely affect installation.
- B. Do not start work until unsatisfactory conditions are corrected.
- C. Work to be concealed: Verify work above support system is complete, tested, and installed in manner which will not affect layout and installation of ceiling system.
- D. Fire-rated assembly: Construction above ceiling system shall meet requirements as applicable to provide fire-resistance rating specified.

**3.02  
Preparation**

- A. Field dimensions: Installer must verify actual field dimensions prior to installation.
- B. Renovation work: Installing contractor shall verify that existing ceiling structure is adequate to support additional COMPASSO Elite ceiling suspension requirement.
- C. Coordination: Coordinate and schedule installation of ceiling system with work of other trades affected by this installation, with particular attention given to mechanical and electrical work required to be installed and operating before ceiling work can begin.

**3.03  
Installation**

- A. Reference: Install in accordance with approved shop drawings and manufacturer's instructions. Follow architects' details for thermal and building expansion joint treatments.
- B. Hanger wires:
  - 1. Spacing: Space hanger wires maximum 48" o.c. along length of carrier system, attached directly to structure above.
  - 2. Limitation: Do not support hanger wires from mechanical and/or electrical equipment, piping, or other equipment occurring above ceiling.
  - 3. Provide additional fixture support as required in accordance with local building codes or other regulatory agencies.
- C. COMPASSO Elite system: Install according to procedure provided by manufacturer and in accordance with approved shop drawings.
  - 1. Perimeter connection detail (recommended) (optional).
- D. Lighting components: Refer to Section 16 \_\_\_\_\_.
- E. Air distribution components: Refer to Section 15 \_\_\_\_\_.

**3.04  
Field Quality  
Control**

- A. Deflection on installed system: Maximum deflection shall not exceed 1/360 of the span.

# C<sup>2</sup> Paired Compasso Channels\*

C<sup>2</sup> Paired COMPASSO Channels are multi-functional design elements that easily integrate lighting and signage, and can be used as way-finding devices throughout a space. These unique ceiling accents combine practicality with dynamic styling for retail spaces, contemporary offices, entertainment and gaming establishments, and education environments.

## Design Flexibility

C<sup>2</sup> Paired COMPASSO Channels are available in straight and curved parts in five different sizes. Create unique configurations using circles, straight pieces, curves, arcs, and angles.

## Functional Style

C<sup>2</sup> Paired COMPASSO Channels complement existing ceilings or open plans without ceilings. They are easy to install and can be suspended from the ceiling with hanger wire, cable, or rods depending upon design criteria. Lighting, displays, or signage can be easily integrated into C<sup>2</sup> Paired COMPASSO Channels—see pages 8-11. C<sup>2</sup> Paired COMPASSO Channels provide a great surface for applied graphics and signage.

## Available Colors

C<sup>2</sup> Paired COMPASSO Channels are available in standard and custom colors. The standard interior colors are Flat White and Silver Satin. For help choosing a custom color, the Sherwin-Williams Color Answers Selector is a good reference. Or simply supply us with a color chip and our paint department will match the color of your choice.

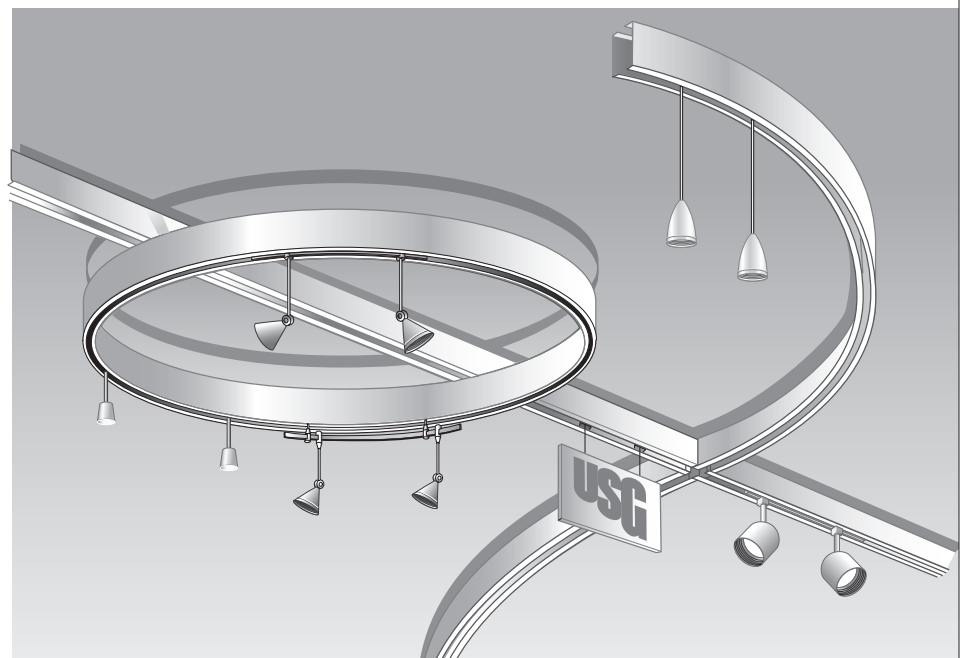

# Components

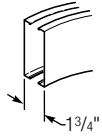
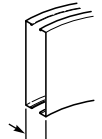
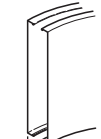
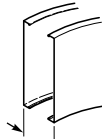
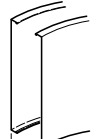
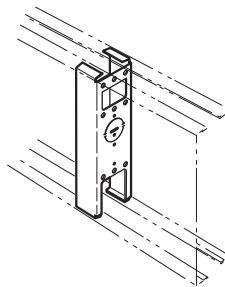
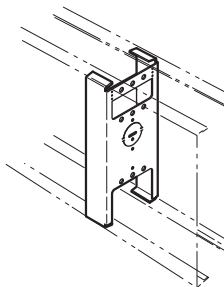
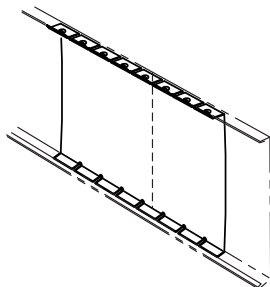
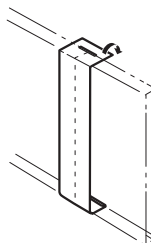
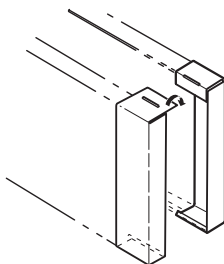
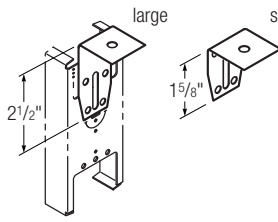
<b>Trim Construction</b>	<b>Narrow Reveal (5/8", 1-3/4" Overall Width)</b>			<b>Wide Reveal (1-3/8", 2-1/2" Overall Width)</b>	
	<b>4" Trim</b>	<b>6" Trim</b>	<b>8" Trim</b>	<b>6" Trim</b>	<b>8" Trim</b>
					
<b>Trim Size</b>	<b>XXXX</b>				
	<b>Hanger Bracket/Narrow Reveal</b>		<b>Hanger Bracket/Wide Reveal</b>		<b>Accessible Splice</b>
					
<b>Accessories</b>	<b>Splice Cover</b>		<b>End Cap</b>		<b>Accessory Angles for Mounting Attachments</b>
					

# Applications

**Layout Example**

**On-Module Ceiling Island**

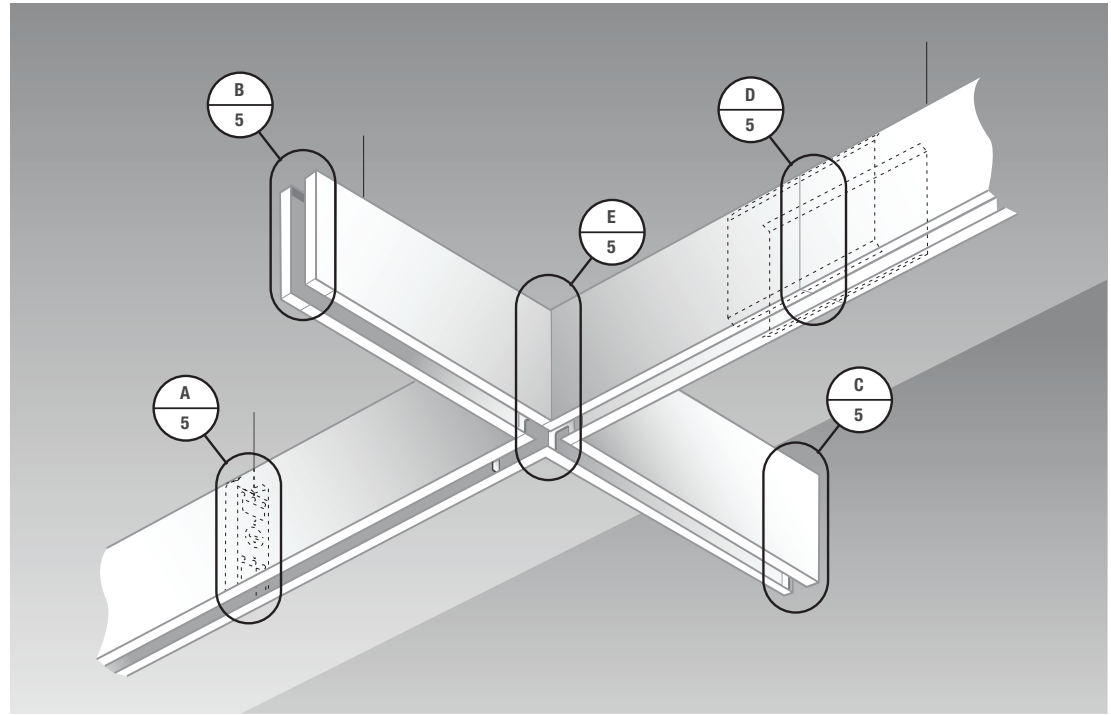

**Details**

**Detail No. 1—Edge Detail Capping Suspension Tee**

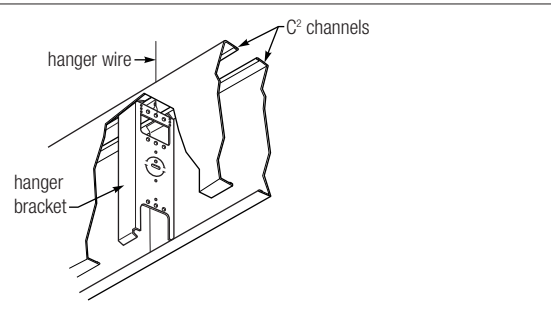

**Detail No. 3—Outside Corner**

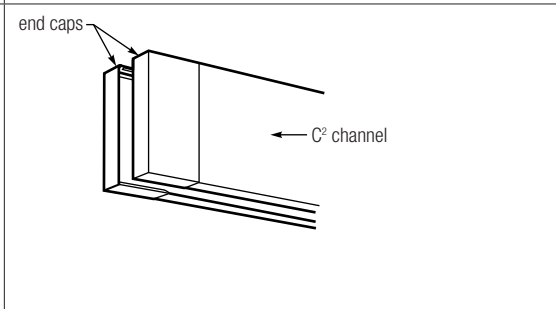

**Detail No. 1A—Edge Detail Parallel to Suspension Tee**

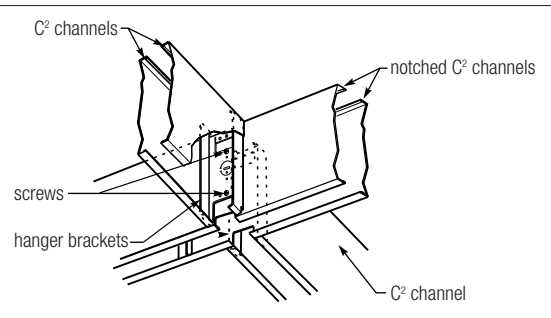

**Detail No. 1A—Section**

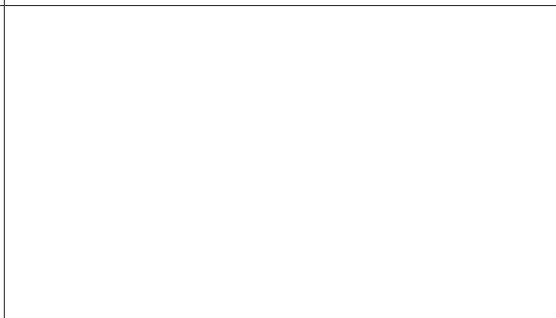

**Details**

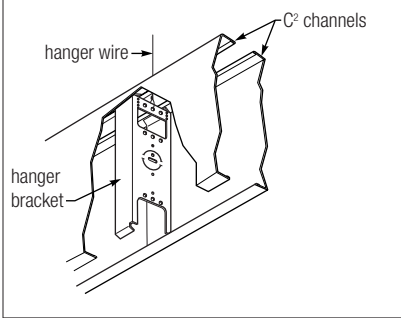
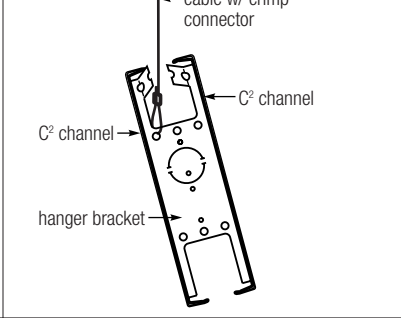
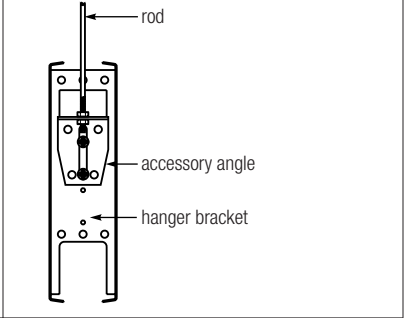
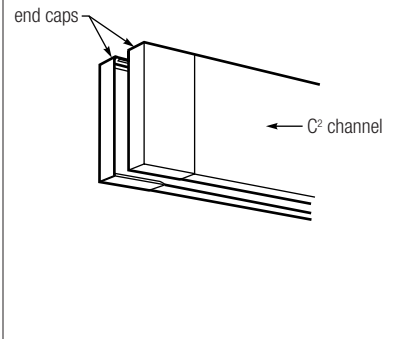
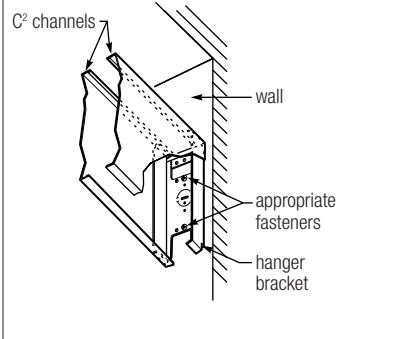
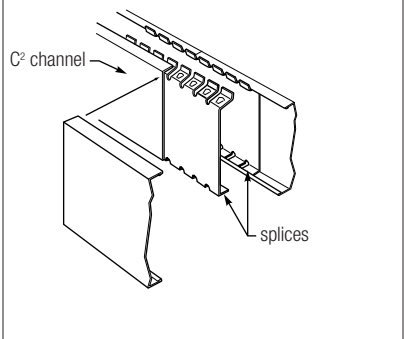
<p><b>A. Hanger Bracket</b></p>  <p>hanger wire hanger bracket C² channels</p>	<p><b>A. Alt-1 (for tilted applications)</b></p>  <p>cable w/ crimp connector C² channel C² channel hanger bracket</p>	<p><b>A. Alt-2</b></p>  <p>rod accessory angle hanger bracket</p>
<p><b>B. End Cap</b></p>  <p>end caps C² channel</p>	<p><b>C. Wall Termination</b></p>  <p>C² channels wall appropriate fasteners hanger bracket</p>	<p><b>D. Splice</b></p>  <p>C² channel splices</p>

**E. 4-way Intersection**

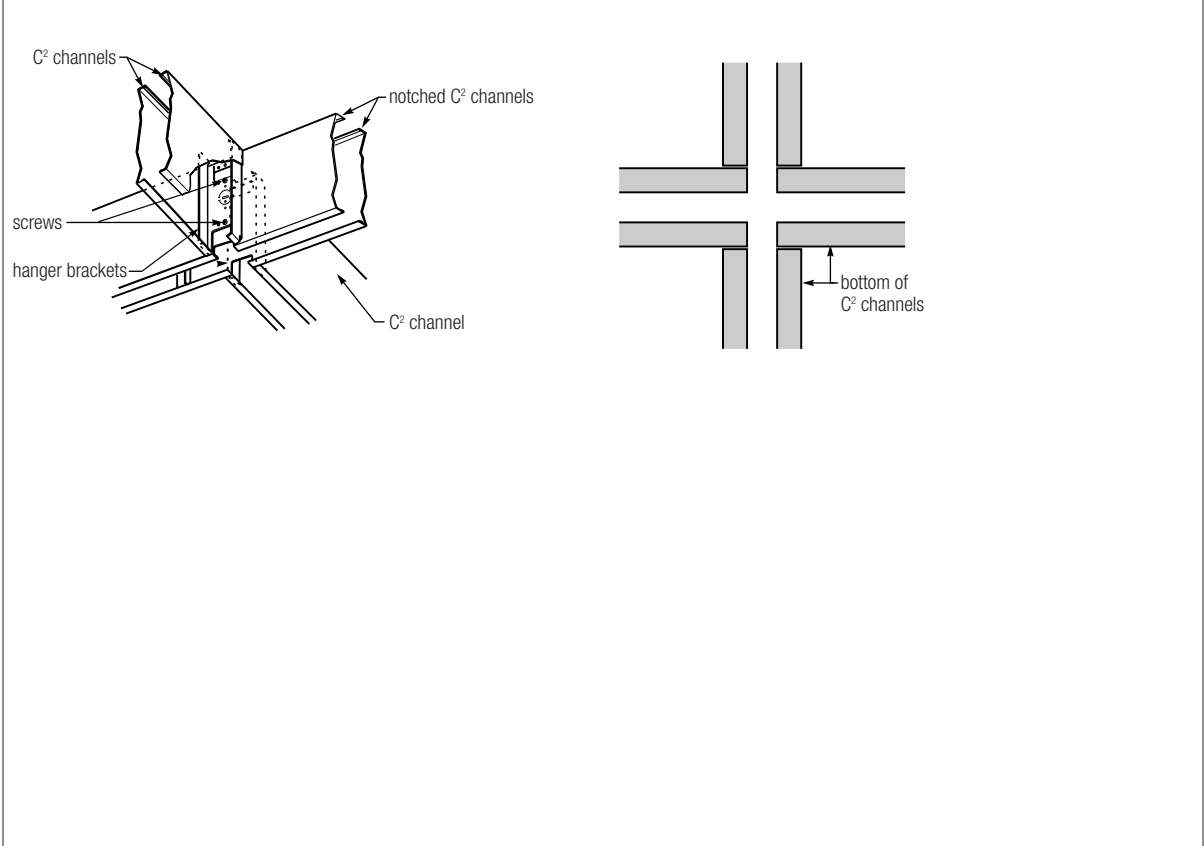

# Corner and Stacked Applications

The system components of C<sup>2</sup> Paired COMPASSO Channels allow you to turn corners precisely at specific angles or curves and to stack the channels vertically.

## Corner and Stacked Perspective

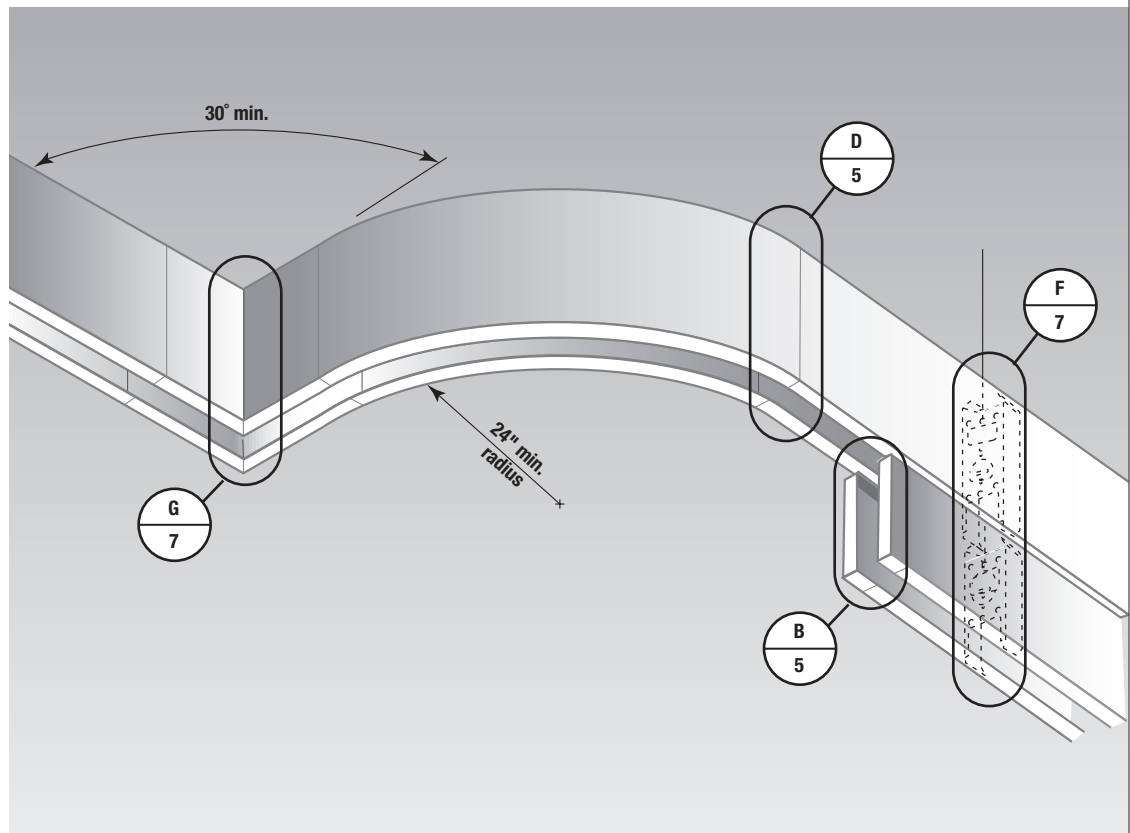

Stack hanger brackets vertically using accessory angles to create a layered ceiling accent, and use splice plates to join independent sections of curved or straight trim to switch direction and turn corners.

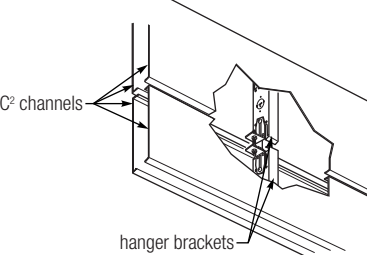
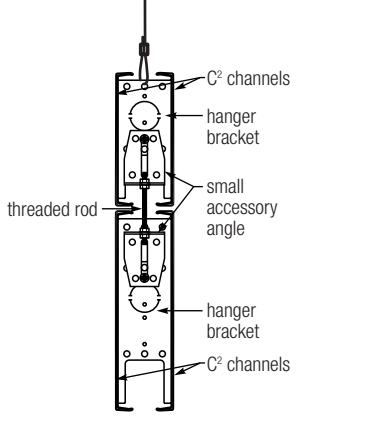
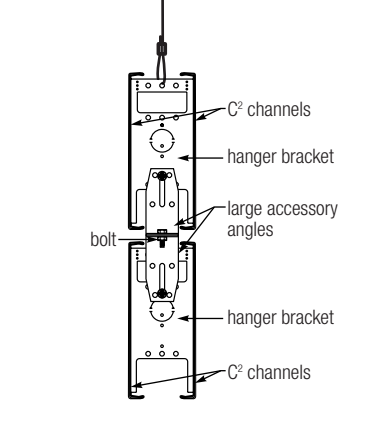
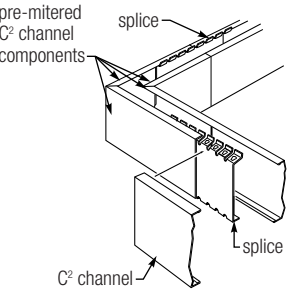
Details	F. Stacked Detail	F. Alt-1	F. Alt-2*
			
	<p><b>G. Corner Detail</b></p> 		

\*Hanger bracket to hanger bracket attachments can only be used with 1-3/8" reveal.

# Lighting and Signage Applications

Light fixtures integrate easily with C<sup>2</sup> Paired COMPASSO Channels to create stunning accents that illuminate any space. Low voltage, neon, and line voltage lighting are ideal for use with C<sup>2</sup> Paired COMPASSO Channels.

## Lighting and Signage Perspective

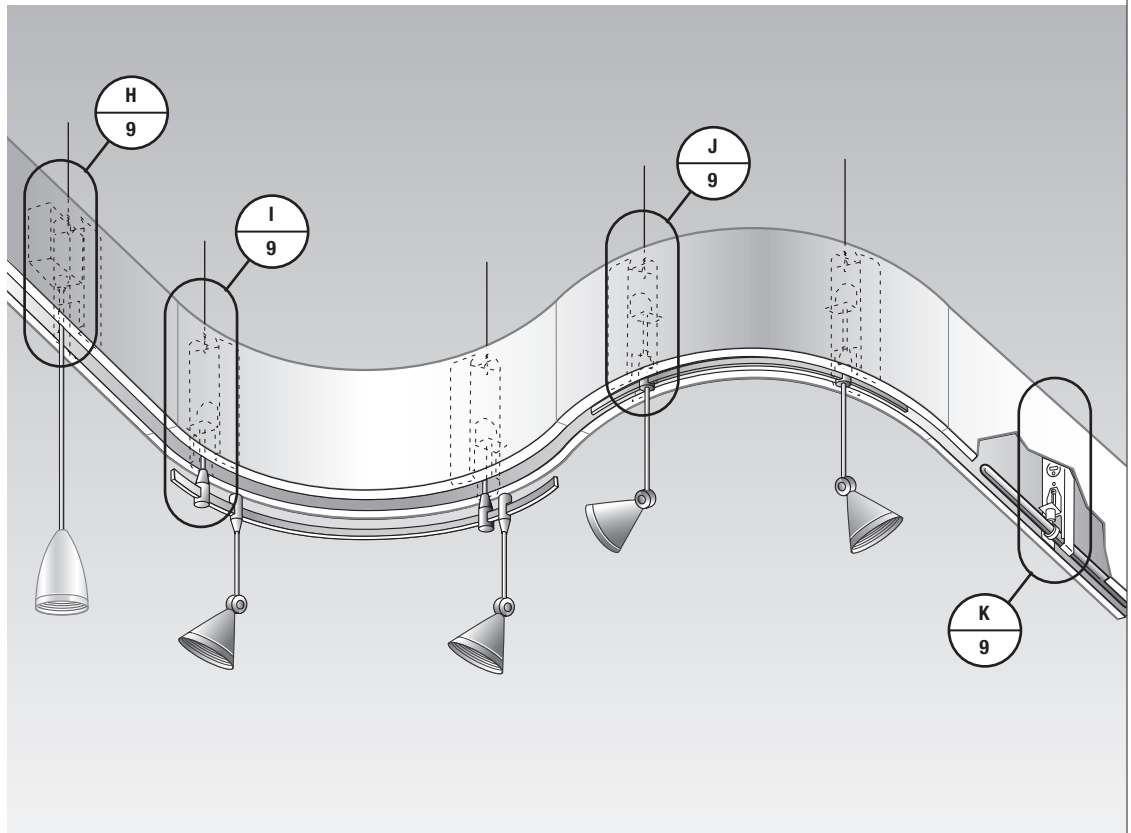

Attach lighting hardware for most types of light fixtures to the hanger brackets and accessory angles used to connect the channels.

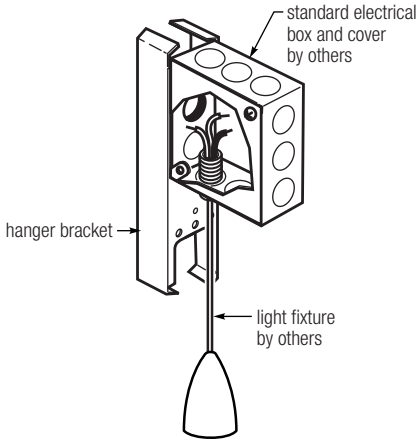
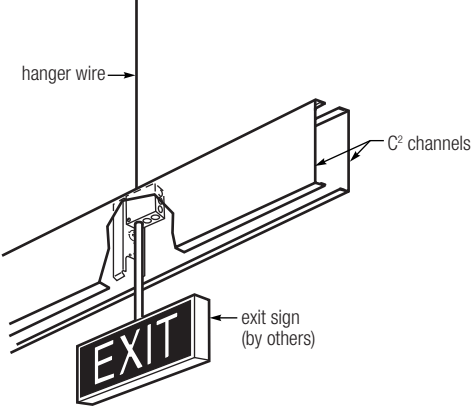
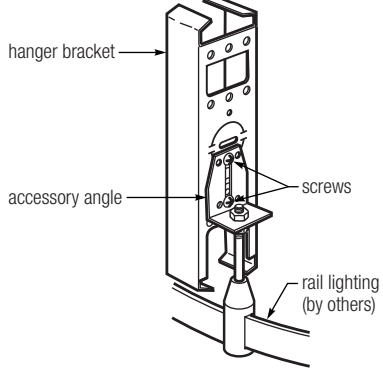
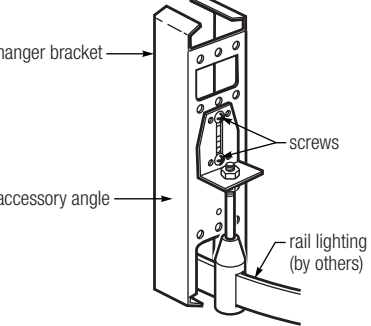
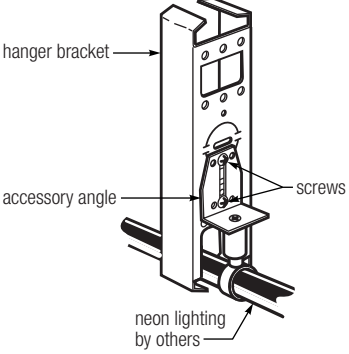
<p><b>Details</b></p>	<p><b>H. Point Lighting</b></p>  <p>standard electrical box and cover by others</p> <p>hanger bracket</p> <p>light fixture by others</p>	<p><b>H. Alt-1, Exit Sign</b></p>  <p>hanger wire</p> <p>C² channels</p> <p>exit sign (by others)</p>
<p><b>I. Flexible Rail Lighting (exposed rail)</b></p>  <p>hanger bracket</p> <p>accessory angle</p> <p>screws</p> <p>rail lighting (by others)</p>	<p><b>J. Flexible Rail Lighting (concealed rail)</b></p>  <p>hanger bracket</p> <p>accessory angle</p> <p>screws</p> <p>rail lighting (by others)</p>	<p><b>K. Neon Lighting</b></p>  <p>hanger bracket</p> <p>accessory angle</p> <p>screws</p> <p>neon lighting (by others)</p>

**Note:** Larger light fixtures and heavier signage should not be suspended from C² Paired COMPASSO Channels. They should be hung independently.

# Ceiling Interface Applications

Different size options can be used to accommodate varying ceiling heights or be hung below a traditional ceiling to add visual interest to any space.

Ceiling Interface  
Perspective

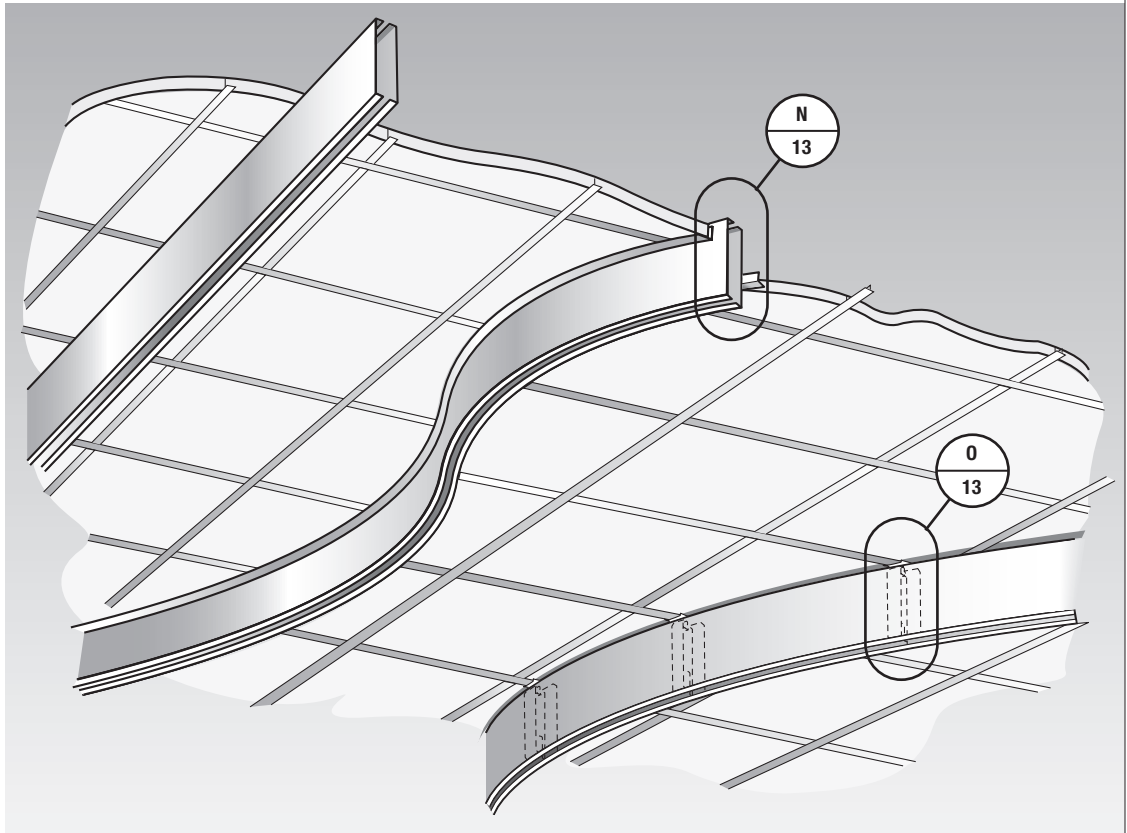

Attach C<sup>2</sup> Paired COMPASSO Channels directly to any ceiling system (flat, drywall, or concrete).

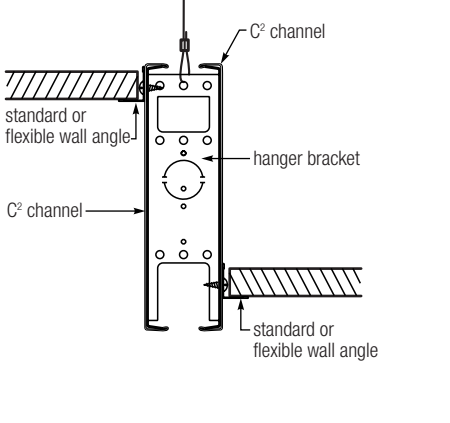
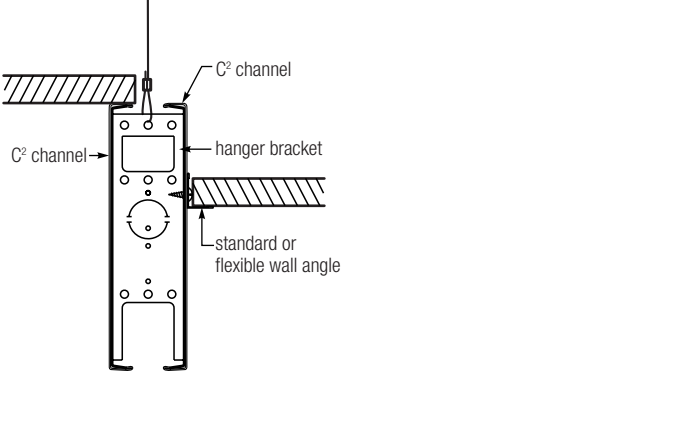
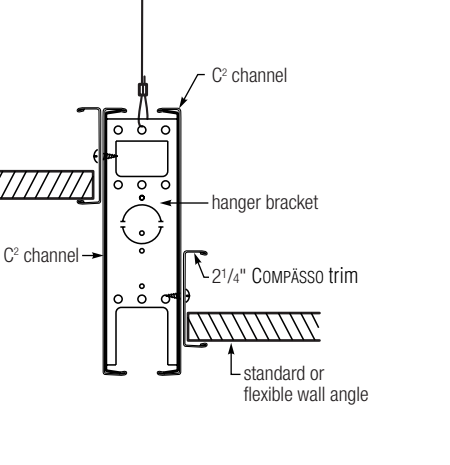
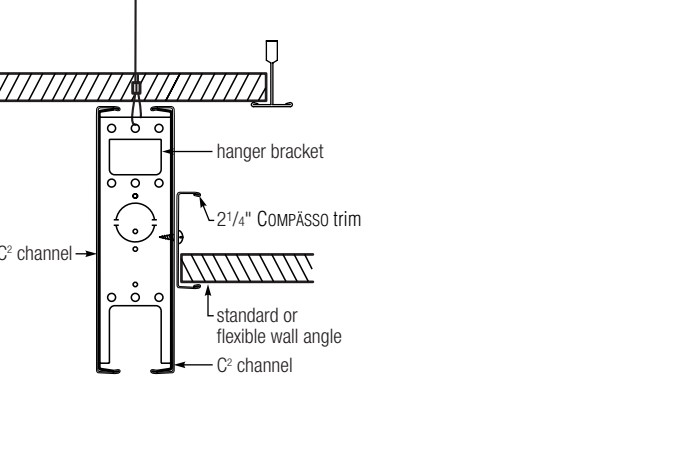
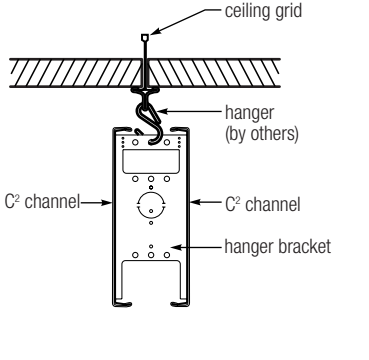
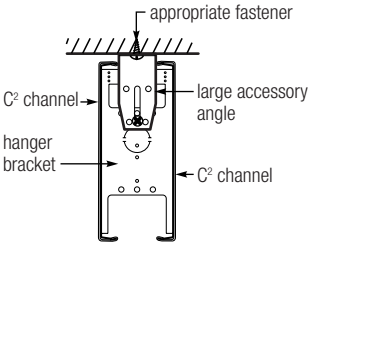
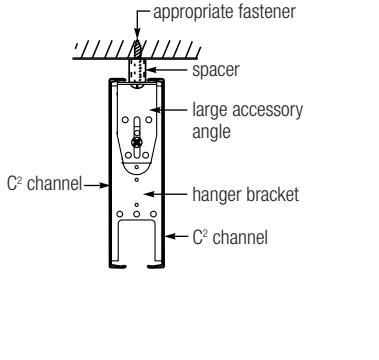
Details	N. Offset Ceiling Interface (straight)	N. Alt-1	
			
			
			

# Application Guide

## Architectural Specifications

Note to specifier: The following specification for the C<sup>2</sup> Paired COMPASSO Channels system is a guide in the preparation of a project specification for an interior nonfire-rated design element. Delete such items that are not related to the particular project. Where blank spaces occur, provide information incidental to the particular project for which the specification is prepared.

The International System of Units (Metric units) is available upon request.  
Section 13\_\_\_\_\_.

**Part 1:  
General**

**1.01  
Description of Work**

- A.** Related work specified elsewhere:
  1. Insulation: Section \_\_\_\_\_.
  2. Mechanical equipment: Section \_\_\_\_\_.
  3. Electrical: Section \_\_\_\_\_.
  4. Gypsum Board systems: Section \_\_\_\_\_.
  5. Acoustical ceilings: Section \_\_\_\_\_.
- B.** Work installed but furnished under other sections: \_\_\_\_\_.
- C.** Work furnished but installed under other sections: \_\_\_\_\_.

**1.02  
System Description**

- A.** C<sup>2</sup> Paired COMPASSO Channels for suspended design elements, consisting of (4" x 5/8" reveal) (6" x 5/8" reveal) (8" x 5/8" reveal) (6" x 1-3/8" reveal) (8" x 1-3/8" reveal) metal sections, straight or curved to radii ranging from a minimum of 18" and sweeping through included angles of 30 degrees or greater. Attachment is provided by specially designed C<sup>2</sup> COMPASSO hanger bracket, which snaps into and locks against hems of COMPASSO trim. Independent sections of trim are joined together using the COMPASSO splice plate.

**1.03  
Quality Assurance**

- A.** Subcontractor qualifications: Installer shall have of successful experience in the installation of suspended ceiling systems with requirements similar to requirements specified.
- B.** Requirements or regulatory agencies: Codes and regulations of authorities having jurisdiction.

**1.04  
References**

- A.** ASTM C635: Standard Specification for the Manufacture, Performance, and Testing of Metal Suspension Systems for Acoustical Tile and Lay-in Panel Ceilings.
- B.** ASTM C636: Standard Practice for Installation of Metal Suspension Systems for Acoustical Tile and Lay-in Panels.
- C.** Cisca Ceiling Systems Installation Handbook.

**1.05  
Submittals**

- A.** Samples: Submit representative sample of color and finish of all exposed materials.
- B.** Shop Drawings:
  1. Reflected ceiling plans: Indicate layout arrangement of ceiling design, dimensions and locations of related integrated lighting and signage components. Include elevation heights and relation to other ceiling planes.
  2. Installation drawings: Detail complete installation including all trim pieces, attachment clips, splice plates, corner pieces, intersections, end caps, and installation of related lighting and signage components.
  3. Manufacturer's data: Submit manufacturer's catalogue cuts or standard drawings showing details of system with project conditions clearly identified and manufacturer's recommended installation instructions.

**1.06  
Delivery, Storage  
and Handling**

- A.** Delivery of materials: Deliver materials in original, unopened packages clearly labeled with the manufacturer's name and identification numbers.
- B.** Inspection: Promptly inspect delivered materials, file freight claims for damage during shipment, and order replacement material, as required.
- C.** Storage: Store in a manner that will prevent scratches or damage of any kind.
- D.** Handling: Handle in such a manner as to ensure against racking, distortion or physical damage of any kind.

1.07 Project Conditions	<p><b>A.</b> Existing conditions: (Include specific alteration work requirements for project.)</p> <p><b>B.</b> Environmental requirements: Building shall be enclosed with windows and exterior doors in place and glazed, and roof watertight before installation of ceiling system and related ceiling components. Climatic conditions range of 60 °F (15.56 °C) to 85 °F (29.44 °C); relative humidity not more than 70%.</p> <p><b>C.</b> Coordination with other work:</p> <ol style="list-style-type: none"> <li>1. Mechanical work: Ductwork above ceiling shall be complete, and permanent heating and cooling systems operating to climate conditions prior to installation of C<sup>2</sup> Paired COMPASSO Channels.</li> <li>2. Electrical work: Installation of conduit above ceiling shall be complete before installation of ceiling components. Coordinate electrical work with installation of C<sup>2</sup> Paired COMPASSO Channels.</li> <li>3. Fire protection work: Fire protection lines and/or equipment occurring above Ceiling shall be completed and tested before ceiling components are installed.</li> </ol> <p><b>D.</b> Protection: Protect completed work above ceiling system from damage during installation of ceiling components.</p>
<b>Part 2:</b> Products	<p><b>2.01</b> Manufacturer</p> <p>C<sup>2</sup> Paired COMPASSO Channels as manufactured by USG Interiors, Inc., Chicago, Illinois, U.S.A.</p>
<b>2.02</b> Materials (Delete items not applicable)	<p><b>A.</b> 4" C<sup>2</sup> Paired COMPASSO system</p> <ol style="list-style-type: none"> <li>1. C<sup>2</sup> Paired COMPASSO Channels: 4" wide face, 9/16" horizontal legs with hems formed for attachment to the mounting bracket creating a 5/8" reveal; commercial quality cold-rolled 24-gauge steel, factory finished in (baked enamel paint finish) ( ) color with gray interior.</li> <li>2. Splice Plate: steel in finish to match trim channels; formed for snap-fit into 4" channel ends.</li> <li>3. Mounting Brackets: steel brackets in manufacturer's standard painted finish, color gray, formed for snap-fit into 4" channels and attached to hanger devices.</li> <li>4. 90° corner trim pieces: to match C<sup>2</sup> Paired COMPASSO Channels</li> <li>5. End caps: to match C<sup>2</sup> Paired COMPASSO Channels</li> <li>6. Accessory Device Bracket: steel accessory angle in (large 2-1/2") (small 1-5/8"), to coordinate with electrical.</li> <li>7. Hanger Devices: Turnbuckle devices and accessories for (1/4" threaded rod) (1/32" diameter aircraft cable)</li> </ol> <p><b>B.</b> 6" C<sup>2</sup> Paired COMPASSO system</p> <ol style="list-style-type: none"> <li>1. C<sup>2</sup> Paired COMPASSO Channels: 6" wide face, 9/16" horizontal legs with hems formed for attachment to the mounting bracket creating a 5/8" reveal; commercial quality cold-rolled 24-gauge steel, factory finished in (baked enamel paint finish) ( ) color with gray interior.</li> <li>2. Splice Plate: steel in finish to match trim channels; formed for snap-fit into 6" channel ends.</li> <li>3. Mounting Brackets: steel brackets in manufacturer's standard painted finish, color gray, formed for snap-fit into 6" channels and attached to hanger devices.</li> <li>4. 90° corner trim pieces: to match C<sup>2</sup> Paired COMPASSO Channels.</li> <li>5. End caps: to match C<sup>2</sup> Paired COMPASSO Channels.</li> <li>6. Accessory Device Bracket: steel accessory angle in (large 2-1/2") (small 1-5/8"), to coordinate with electrical.</li> <li>7. Hanger Devices: Turnbuckle devices and accessories for (1/4" threaded rod) (1/32" diameter aircraft cable).</li> </ol> <p><b>C.</b> 8" C<sup>2</sup> Paired COMPASSO system</p> <ol style="list-style-type: none"> <li>1. C<sup>2</sup> Paired COMPASSO Channels: 8" wide face, 9/16" horizontal legs with hems formed for attachment to the mounting bracket creating a 5/8" reveal; commercial quality cold-rolled 24-gauge steel, factory finished in (baked enamel paint finish) ( ) color with gray interior.</li> <li>2. Splice Plate: steel in finish to match trim channels; formed for snap-fit into 8" channel ends.</li> <li>3. Mounting Brackets: steel brackets in manufacturer's standard painted finish, color gray, formed for snap-fit into 8" channels and attached to hanger devices.</li> <li>4. 90° corner trim pieces: to match C<sup>2</sup> Paired COMPASSO Channels.</li> <li>5. End caps: to match C<sup>2</sup> Paired COMPASSO Channels.</li> <li>6. Accessory Device Bracket: steel accessory angle in (large 2-1/2") (small 1-5/8"), to coordinate with electrical.</li> <li>7. Hanger Devices: Turnbuckle devices and accessories for (1/4" threaded rod) (1/32" diameter aircraft cable).</li> </ol>

# Application Guide

## Architectural Specifications

- D. 6" C<sup>2</sup> Paired COMPASSO system
  - 1. C<sup>2</sup> Paired COMPASSO Channels: 6" wide face, 9/16" horizontal legs with hems formed for attachment to the mounting bracket creating a 1-3/8" reveal; commercial quality cold-rolled 24-gauge steel, factory finished in (baked enamel paint finish) ( ) color with gray interior.
  - 2. Splice Plate: steel in finish to match trim channels; formed for snap-fit into 6" channel ends.
  - 3. Mounting Brackets: steel brackets in manufacturer's standard painted finish, color gray, formed for snap-fit into 6" channels and attached to hanger devices.
  - 4. 90° corner trim pieces: to match C<sup>2</sup> Paired COMPASSO Channels.
  - 5. End caps: to match C<sup>2</sup> Paired COMPASSO Channels.
  - 6. Accessory Device Bracket: steel accessory angle in (large 2-1/2") (small 1-5/8"), to coordinate with electrical.
  - 7. Hanger Devices: Turnbuckle devices and accessories for (1/4" threaded rod) (1/32" diameter aircraft cable).
- E. 8" C<sup>2</sup> Paired COMPASSO system
  - 1. C<sup>2</sup> Paired COMPASSO Channels: 8" wide face, 9/16" horizontal legs with hems formed for attachment to the mounting bracket creating a 1-3/8" reveal; commercial quality cold-rolled 24-gauge steel, factory finished in (baked enamel paint finish) ( ) color with gray interior.
  - 2. Splice Plate: steel in finish to match trim channels; formed for snap-fit into 8" channel ends.
  - 3. Mounting Brackets: steel brackets in manufacturer's standard painted finish, color gray, formed for snap-fit into 8" channels and attached to hanger devices.
  - 4. 90° corner trim pieces: to match C<sup>2</sup> Paired COMPASSO Channels.
  - 5. End caps: to match C<sup>2</sup> Paired COMPASSO Channels.
  - 6. Accessory Device Bracket: steel accessory angle in (large 2-1/2") (small 1-5/8"), to coordinate with electrical.
  - 7. Hanger Devices: Turnbuckle devices and accessories for (1/4" threaded rod) (1/32" diameter aircraft cable).
- F. For specific project details and bill of materials see USG Interior Drawing No. RTQ - \_\_\_\_\_ (provided by USG sales representative)

**2.03  
Fabrication**

- A. Trim channels: Edges formed to snap onto mounting brackets and provide positive mechanical lock with no visible fasteners. Factory finished to match approved samples.
- B. Splice Plates: Formed to snap into and provide positive lock between abutting channels with no visible fasteners. Factory finished to match trim channels.
- C. Mounting brackets: Formed to snap into trim channels and provide positive mechanical lock with no visible fasteners while providing interface for hanging attachment and integration of lighting or signage.

**Part 3:  
Execution**

**3.01  
Inspection**

- A. Examine areas to receive trim system for conditions which will adversely affect installation.
- B. Do not start work until unsatisfactory conditions are corrected.
- C. Work to be concealed: Verify work above support system is complete, tested, and installed in a manner which will not affect layout and installation of channel system.
- D. Fire-rated assembly: Construction above channel system shall meet requirements as applicable to provide fire-resistance rating specified.

**3.02  
Preparation**

- A. Field dimensions: Installer must verify actual field dimensions prior to installation.
- B. Renovation work: Installing contractor shall verify that existing ceiling structure is adequate to support additional C<sup>2</sup> Paired COMPASSO Channel system.
- C. Coordination: Coordinate and schedule installation of channel system with work of other trades affected by this installation, with particular attention given to mechanical and electrical work required to be installed and operating before ceiling work can begin. Coordinate electrical with integration into channel system, if required.

---

**3.03  
Installation**

- A.** Reference: Install in accordance with approved shop drawings and manufacturer's instructions. Follow architects' details for thermal and building expansion joint treatments.
- B.** Hanger wires:
  - 1.** Spacing: Space hanger wires maximum 48" o.c. along straight sections and maximum 36" o.c. along curved sections of channels, or as noted otherwise by manufacturer on shop drawings. Attach directly to structure above.
  - 2.** Limitation: Do not support hanger wires from mechanical and/or electrical equipment, piping, or other equipment occurring above ceiling.
  - 3.** Provide additional fixture support as required in accordance with local building codes or other regulatory agencies.
- C.** C<sup>2</sup> Paired COMPASSO Channel system: Install according to procedure provided by manufacturer and in accordance with approved shop drawings.
- D.** Lighting components: Refer to Section 16\_\_\_\_\_.
- E.** Air Distribution components: Refer to Section 15\_\_\_\_\_.

---

**3.04  
Field Quality  
Control**

- A.** Deflection on installed system: Maximum deflection shall not exceed 1/360 of the span.







Architect: BSA LifeStructures  
Photo: Fungi Media © USG Interiors, LLC

**Technical Service**  
800 USG.4YOU

**Website**  
usg.com

**Samples/Literature E-mail**  
samplit@usg.com

**Customer Service**  
800 950.3839

IC400/12-25  
© 2025, USG Corporation or its affiliates.  
All rights reserved.

**Notice**  
The information in this document is subject to change without notice. CGC Inc. or USG Corp. assumes no responsibility for any errors that may inadvertently appear in this document.

Manufactured by  
USG Interiors, LLC  
550 West Adams Street  
Chicago, IL 60661

**Note**

All products described here may not be available in all geographic markets and are subject to change without notice. Consult your local sales office or representative for information.

**Trademarks**

The trademarks USG, CGC, CELEBRATION, CENTRICITEE, COMPASSO, DONN, DX, DXW FINELINE, PARALINE, TRUE WOOD, IT'S YOUR WORLD. BUILD IT., the USG/CGC logo, the design elements and colors, and related marks are trademarks of USG Corporation or its affiliates.

**Notice**

We shall not be liable for incidental or consequential damages, directly or indirectly sustained, nor for any loss caused by application of these goods not in accordance with current printed instruction or for other than intended use. Our liability is expressly limited to replacement of defective goods. Any claim shall be deemed waived unless made in writing to us within thirty (30) days from the date it was or reasonably should have been discovered.

**Safety First!**

Follow good safety/industrial hygiene practices during installation. Wear appropriate personal protective equipment. Read MSDS and literature before specification and installation.

**USG**  **CGC**  
IT'S YOUR WORLD. BUILD IT.®