

Get in the Rhythm



Geometrix™

Metal Ceiling Panels

Offices
Lobbies
Conference Rooms
Schools
Retail
Hospitality
Entertainment
Health Care
Transportation Hubs

GEOMETRIX™ Metal Ceiling Panels provide a dynamic and versatile design element that can instill calm and serenity with quiet, simple lines or turn up the energy with taut angles and rhythmic patterns.



A Dramatic Statement

User's Guide

GEOMETRIX™ Metal Ceiling Panels are 3-dimensional, lightweight aluminum panels that lend unique perspective and unexpected dimension to ceiling space. Offered in a variety of designs and in varying depths, the panels install easily into 9/16" narrow-profile and 15/16" standard suspension systems.

	Pages	
Understand Your System	3	Overview Components
Design Your System	8	Design Tools Acoustical Performance Fire-Rated Performance
Specify Your System	18	Application Guide Specifications
For More Information		Technical Service 800 USG.4YOU Web Site usg.com

Geometrix™ Metal Ceiling Panels

Panels	The 2' x 2' GEOMETRIX Metal Ceiling Panels are offered in four panel designs and in varying panel depths. The profiles can be combined to create 3-D patterns or used randomly for dimensional variety. The lay-in panels are available in two standard colors: Flat White and Silver Satin. Custom colors are available on request (no minimum required). The panels are offered in solid metal or in a choice of five perforated patterns.
Suspension Systems	The lightweight, lay-in panels install into narrow-profile and standard suspension systems and allow full ceiling accessibility.
Perimeter Details	Optional COMPASSO™ Edge Trim may be added for a more finished appearance at exposed edges. (See IC400 in the USG Specialty Ceilings binder for more information.)
Lighting and Utility Access	GEOMETRIX Metal Ceiling Panels can be specified with custom-sized and custom-positioned pre-engineered utility circles to allow for easy integration of lighting and utilities.
Acoustical Performance	Perforated GEOMETRIX Metal Ceiling Panels come standard with USG's ACOUSTIBOND™ factory-applied backer for enhanced sound performance.

System Overview

GEOMETRIX Metal Ceiling Panels are offered in four panel profiles: flat, wedge-shaped and wedge-shaped inside corners and outside corners. The flat panels come in a choice of four depths: 5/16", 1-1/4", 2-1/4" and 3-1/4". The wedge-shaped panels come in a choice of three depths: 1-1/4", 2-1/4" and 3-1/4".

Product Information	Materials	Panels: Aluminum. GEOMETRIX panels meet ASTM E84 Class A requirements for Surface Burning Characteristics. Suspension system: All DONN® Brand 9/16" CENTRICITEE,™ FINELINE® and 15/16" DX® profiles Edge trim system: Painted cold rolled steel
	Finishes	GEOMETRIX panels are available in solid metal or in a choice of five perforated patterns (C375, D250, D375, C062 and C062A). A black ACOUSTIBOND backer is included standard with all perforated panels unless otherwise specified. The ACOUSTIBOND backer is also available in white. (See page 6 for more details.)
	Colors	Standard colors: Flat White and Silver Satin. Custom colors are available on request.
	Size and Weight	Panels: 2' x 2' Weight (for 3" deep flat panel): 0.75 lbs./sf.

Assembly

View from Above

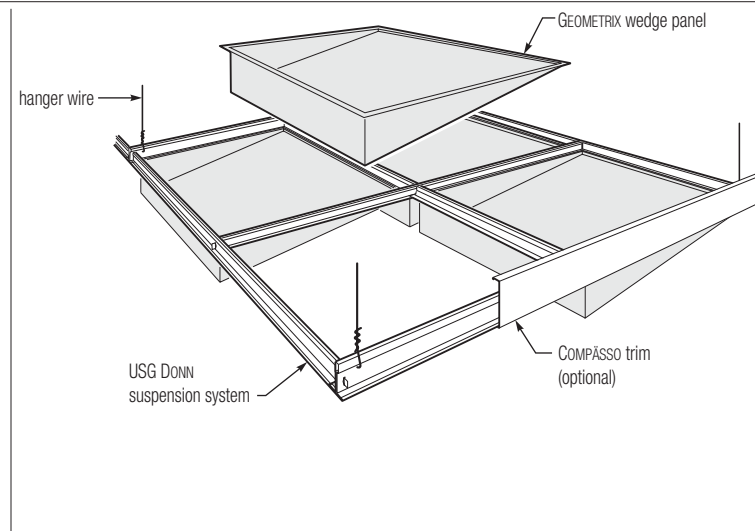

System Components

Panel Options **Shapes**

GEOMETRIX Metal Ceiling Panels can be used in conjunction with standard acoustical panels, or any other 2' x 2' lay-in panels from USG Interiors, to create an unlimited range of truly one-of-a-kind dimensional treatments.

Use the following selector key to specify panels for your GEOMETRIX ceiling designs.

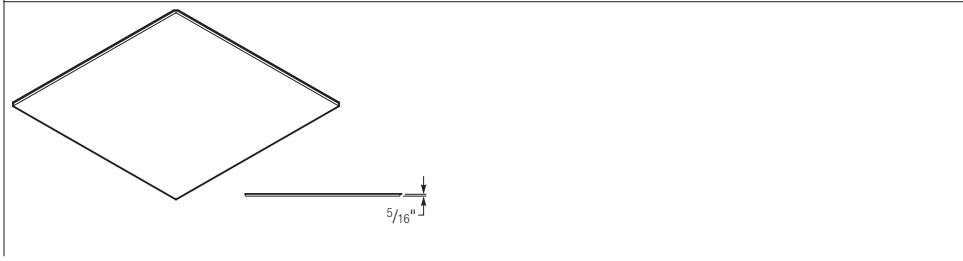
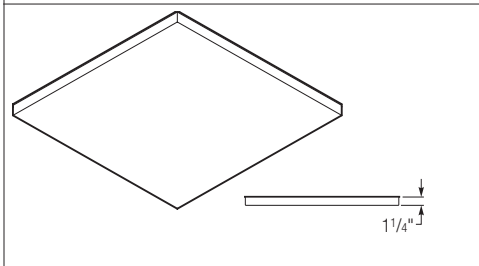
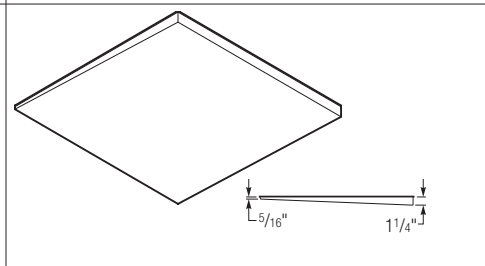
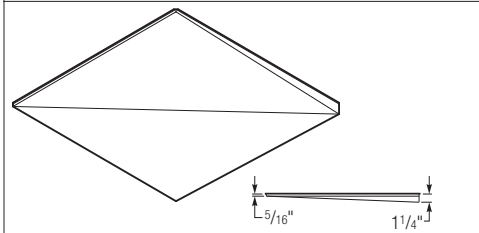
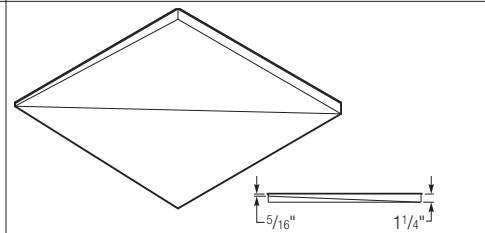
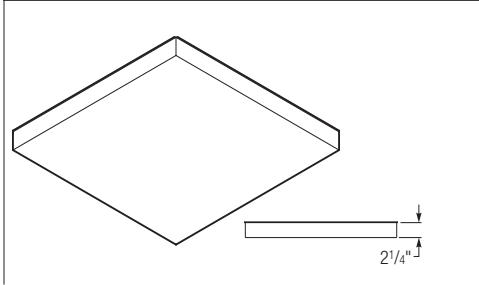
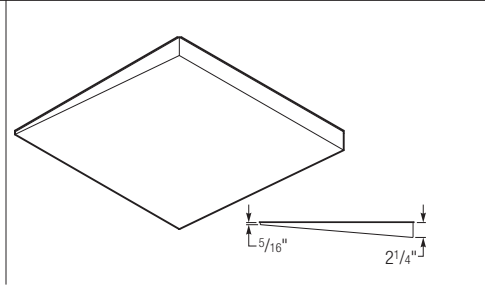
<p>5/16" Panel Depth</p>	<p>GEOMETRIX Flat = GF-0</p> 	
<p>1-1/4" Panel Depth</p>	<p>GEOMETRIX Flat = GF-1</p> 	<p>GEOMETRIX Wedge = GW-1</p> 
	<p>GEOMETRIX Outside Wedge Corner = GOC-1</p> 	<p>GEOMETRIX Inside Wedge Corner = GIC-1</p> 
<p>2-1/4"</p>	<p>GEOMETRIX Flat = GF-2</p> 	<p>GEOMETRIX Wedge = GW-2</p> 

Panel Options 2-1/4"
Panel Depth

GEOMETRIX Outside Wedge Corner = GOC-2

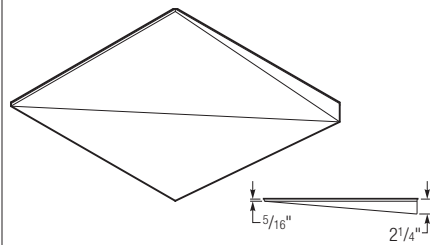

GEOMETRIX Inside Wedge Corner = GIC-2

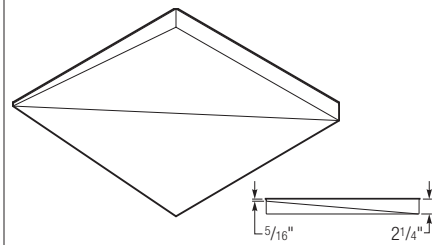

3-1/4"
Panel Depth

GEOMETRIX Flat = GF-3

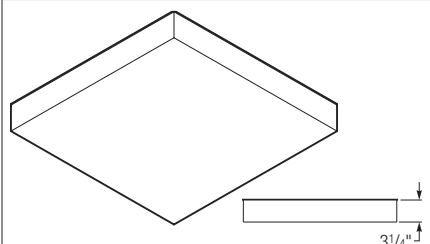

GEOMETRIX Wedge = GW-3

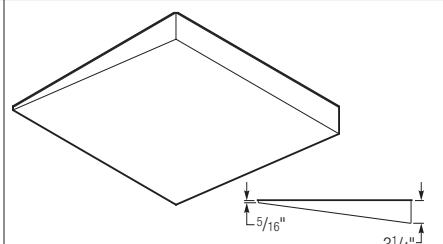

GEOMETRIX Outside Wedge Corner = GOC-3

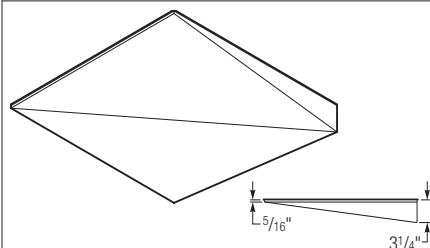

GEOMETRIX Inside Wedge Corner = GIC-3

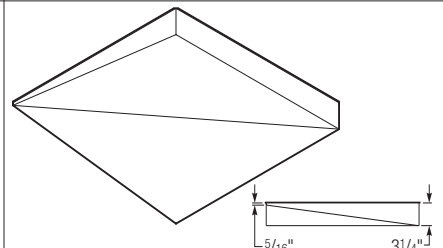

Colors

Flat White and Silver Satin. Custom colors are available on request (no minimum order required).

Integrated Lighting and Utilities

GEOMETRIX Metal Ceiling flat and wedge panels can be specified with custom-sized and custom-positioned pre-engineered utility circles for easy integration of lighting and utilities.

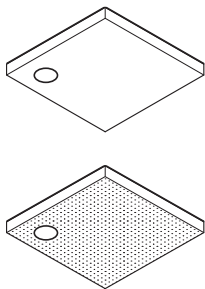

Utility Circle in Solid Panel

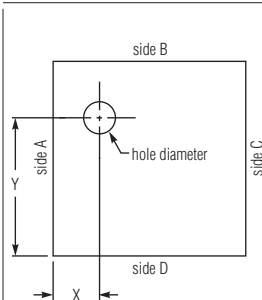

Utility Circle in Perforated Panel

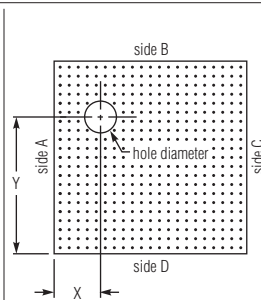

System Components

Panel Options **Solid or Perforated**

GEOMETRIX panels are available in solid metal or in a choice of five perforated patterns (shown below at 50% size).

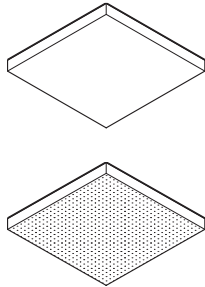

Pattern No. C375	Pattern No. D250	Pattern No. D375
Round—3/8" perforations 1.125" o.c., 9% open area	Square—1/4" perforations .75" o.c., 11% open area	Square—3/8" perforations 1.125" o.c., 11% open area
Pattern No. C062	Pattern No. C062A	
Round—1/16" perforations .351" o.c., 3% open area	Round—1/16" perforations .176" o.c., 8% open area	

Acoustical Performance

Perforated GEOMETRIX Metal Ceiling Panels come standard with a black, factory-applied USG ACOUSTIBOND backer for enhanced sound performance. The ACOUSTIBOND backer is included on all perforated panels unless otherwise specified. The ACOUSTIBOND backer is also available in white.

Standard (with black ACOUSTIBOND Backer)	Optional (without ACOUSTIBOND Backer)

Suspension Systems

The lightweight, durable GEOMETRIX Metal Ceiling Panels install quickly and easily into narrow-profile (9/16") CENTRICITEE (DXT), FINELINE DXF, FINELINE 1/8 (DXFF) suspension systems, as well as standard (15/16") suspension systems.

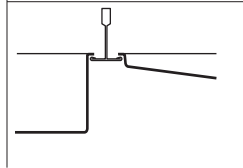
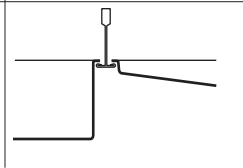
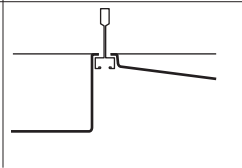
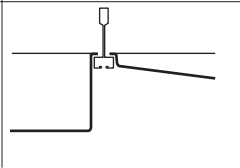
Edge Details	GEOMETRIX Panels with 15/16" DONN Brand DX Suspension	GEOMETRIX Panels with 9/16" DONN Brand CENTRICITEE (DXT) Suspension	GEOMETRIX Panels with 9/16" FINELINE (DXF) Suspension	GEOMETRIX Panels with 9/16" FINELINE (DXFF) Suspension
				

COMPASSO™ Edge Trim

Optional edge trim in 2-1/4", 4", 6" or 8" heights may be added for a more finished appearance.

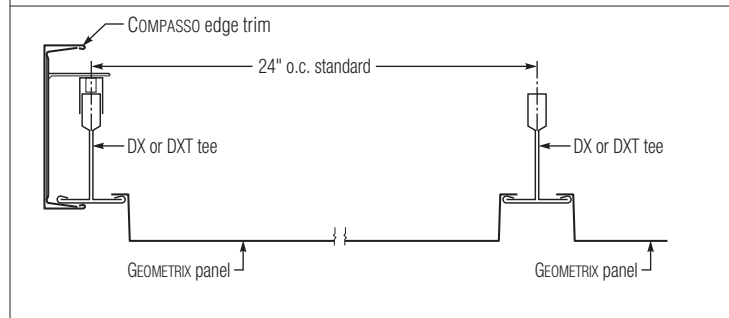
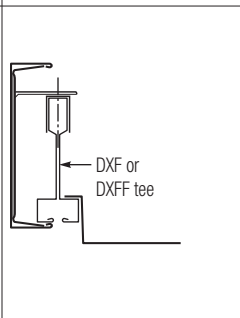
DX or DXT Profile	DXF or DXFF Profile
	

Perimeter Details

Non-Wall or "Floating" Condition

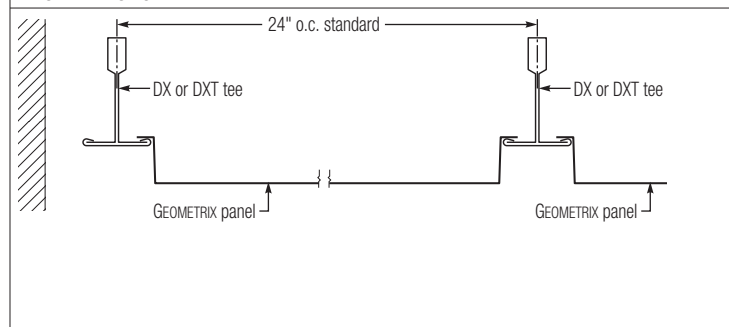
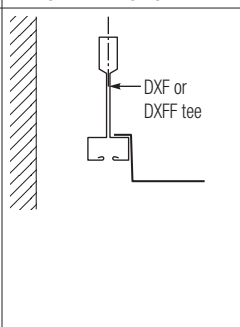
DX or DXT Profile	DXF or DXFF Profile
	

Wall Condition

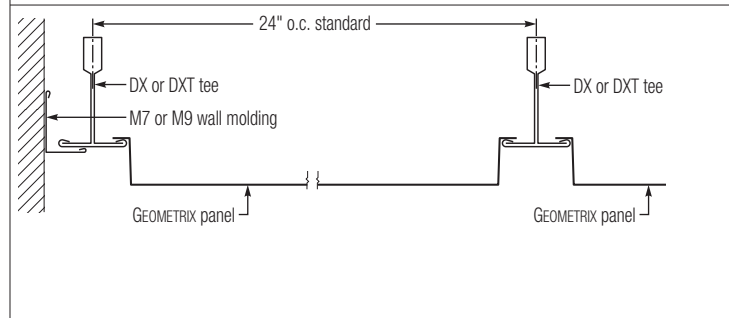
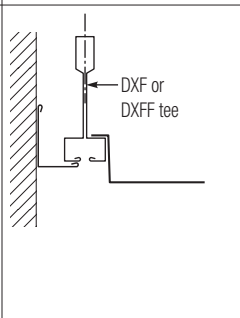



DX or DXT Profile	DXF or DXFF Profile
	

Design Tools

GEOMETRIX Metal Ceiling Panels can be designed using three interactive design tools: the GEOMETRIX Online Designer, GEOMETRIX CAD Blocks or the USG Design Wizard.

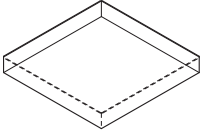
GEOMETRIX CAD Blocks

GEOMETRIX DXF Blocks offer designers a simple, time saving means for creating GEOMETRIX Metal Ceiling Panel designs in most CAD systems. The DXF blocks, which can be downloaded for free from the *Online Tools* section of the USG web site (usg.com), are compatible with nearly all CAD systems.

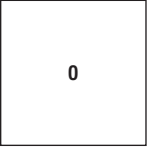
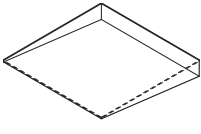
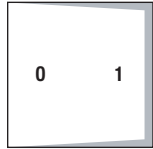
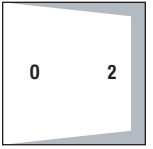
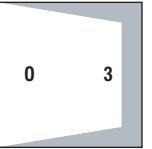
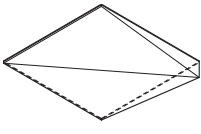
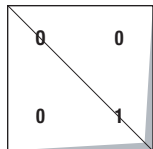
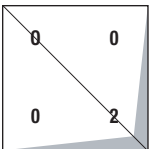
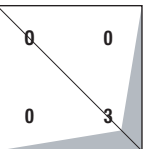
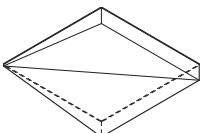
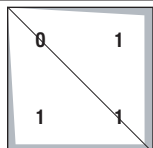
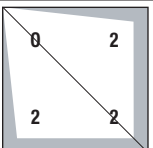
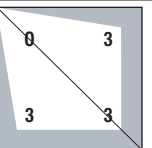
Flat 	GF-1 	GW-2 	GW-3 	GF-0 
Wedge 	GW-1 	GW-2 	GW-3 	
Outside Corner 	GOC-1 	GOC-2 	GOC-3 	
Inside Corner 	GIC-1 	GIC-2 	GIC-3 	

GEOMETRIX Online Designer

This interactive design tool, available in the *Online Tools* section of the USG web site (usg.com), enables architects and designers to intuitively define, create and view multiple GEOMETRIX Metal Ceiling Panel designs. Users simply define the dimensions of a desired ceiling space and then drop-and-drag GEOMETRIX ceiling panels into 2' x 2' suspension system modules, which are automatically created within the defined space. Panels can be removed or reconfigured at will—and it's all done on the Internet in real time. Selected designs can be downloaded and seamlessly integrated with AutoCAD and other CAD design software.

GEOMETRIX Online Designer

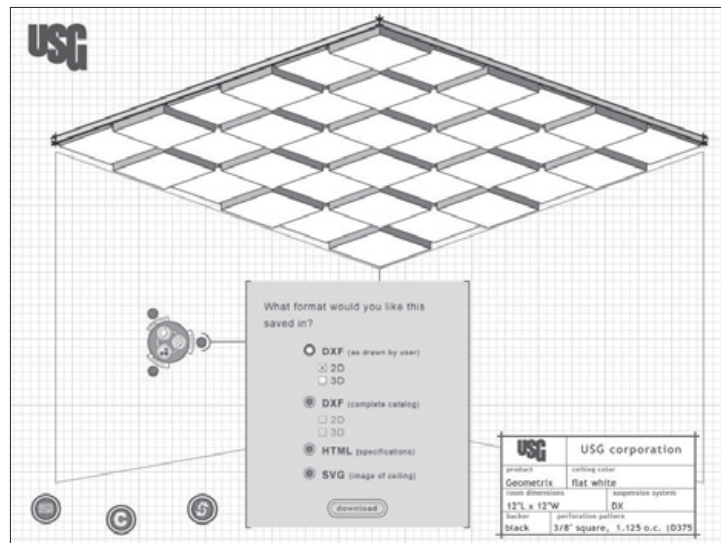

USG Design Wizard

The USG Design Wizard is an intuitive, interactive software tool that enables specifiers to quickly generate 3-D designs featuring GEOMETRIX Metal Ceiling Panels, as well as a wide range of other acoustical and specialty ceiling systems from USG Interiors. The Design Wizard integrates seamlessly with AutoCAD Release 2000, 2000i, 2002 and ADT 3.0 to allow designers to view full-color 3-D designs and create specifications.

The USG Design Wizard can be downloaded for free from the USG web site (usg.com). The download is recommended for high-speed connections only. To request the Design Wizard on CD, register online or contact USG's Sample and Literature department by calling 888.874-2450 or e-mailing samplit@usg.com. The USG Design Wizard Help Desk can be contacted by calling 877.919.0546, or by e-mailing USGdwHelp@perceptual-eng.com.

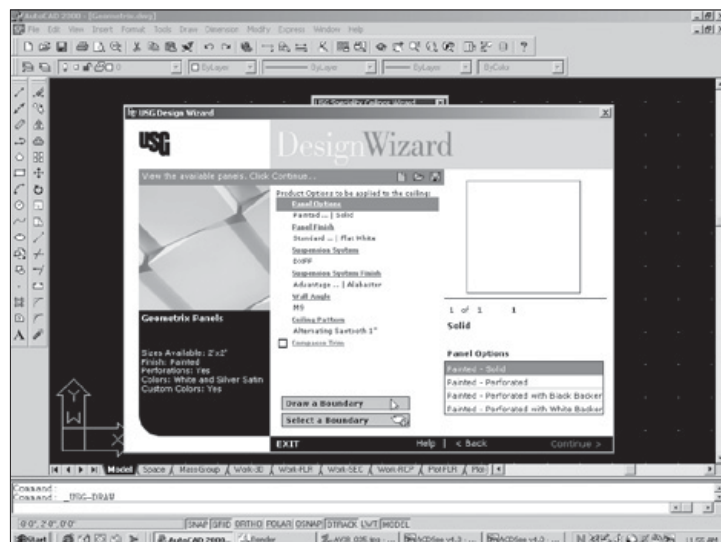

Design Concepts

GEOMETRIX Metal Ceiling Panels can be configured in a wide range of patterns and random designs. The illustrations in this section show some basic design concepts. Of course, these are just a few ideas. You're only limited by your imagination.

Basketweave Pattern Perspective

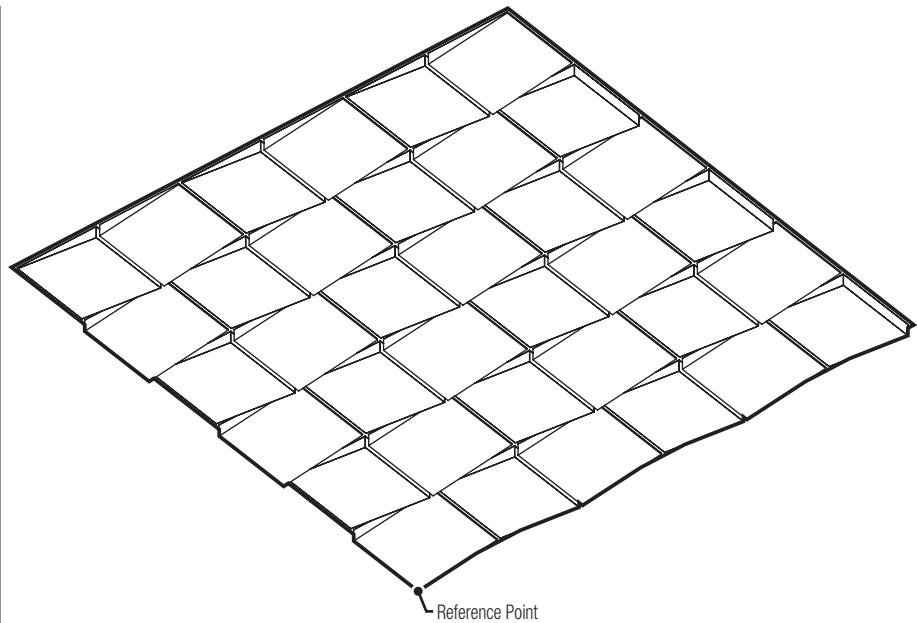

Reflected Ceiling Plan
Using GEOMETRIX
CAD Blocks

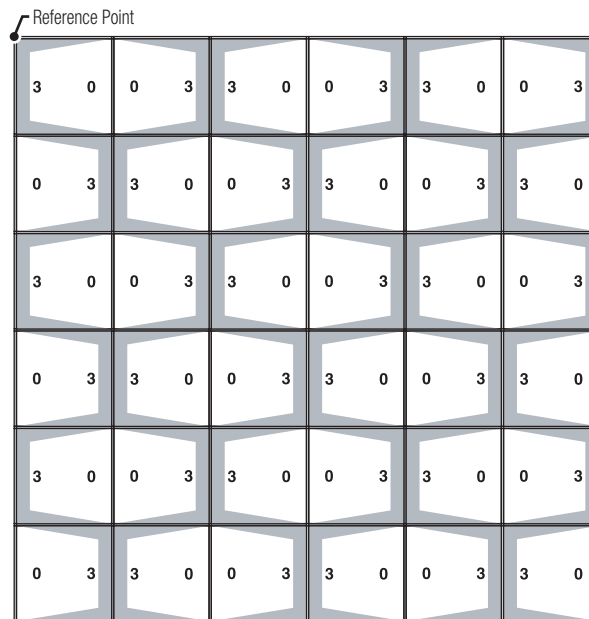

Coffered Pattern

Perspective

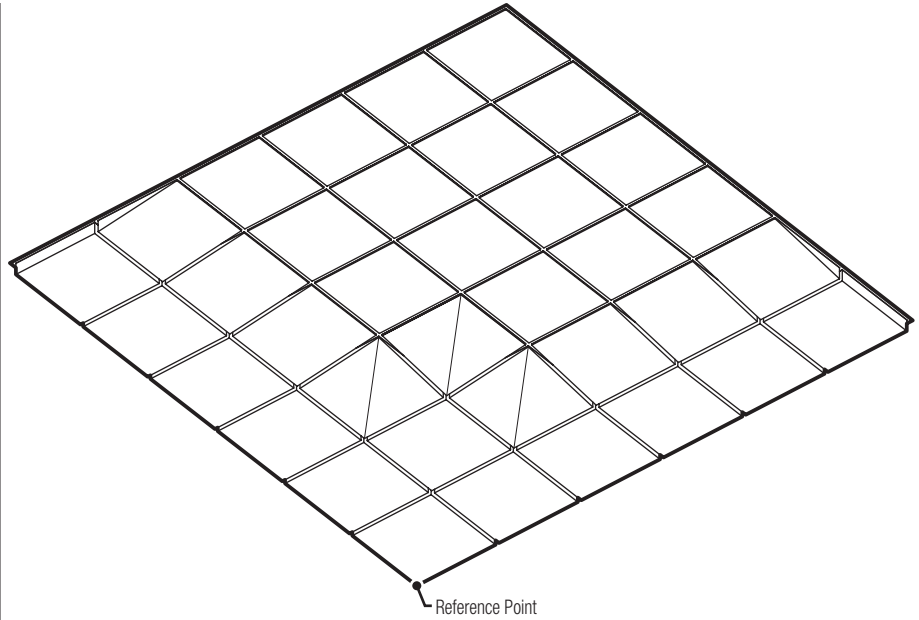

Reflected Ceiling Plan Using GEOMETRIX CAD Blocks

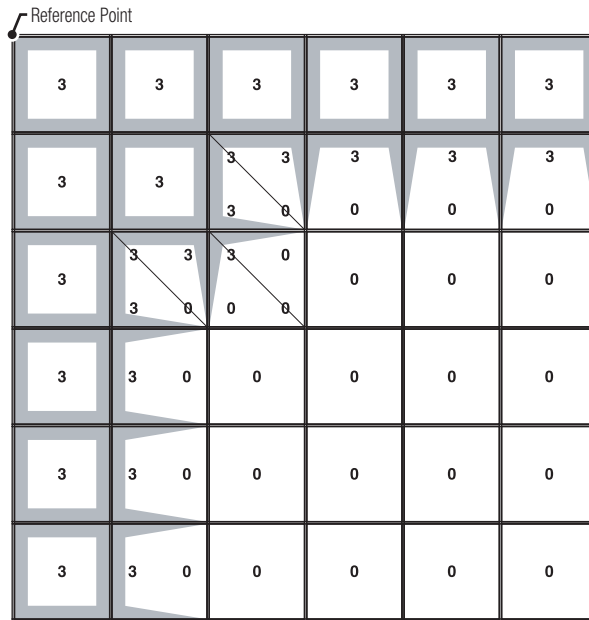

Design Concepts

**Sawtooth
Pattern**

Perspective

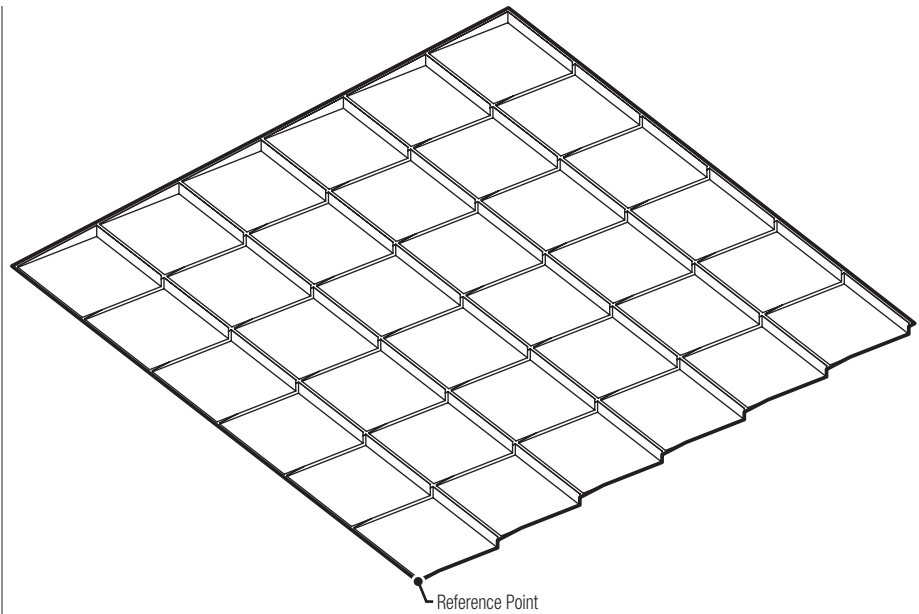

**Reflected
Ceiling Plan
Using GEOMETRIX
CAD Blocks**

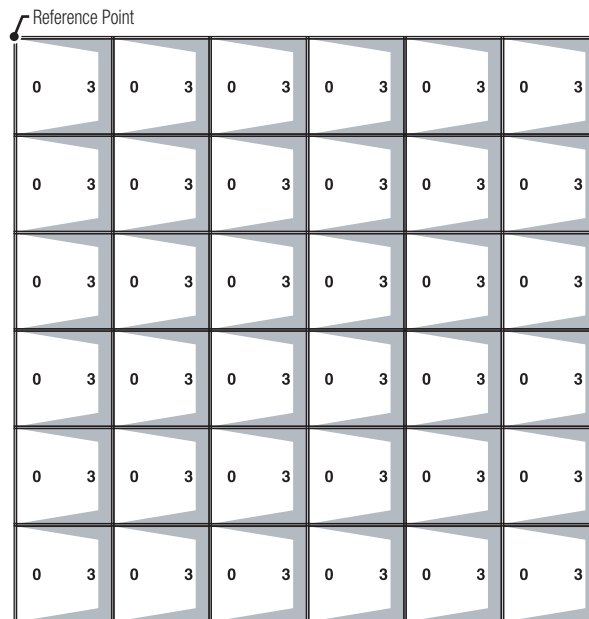

**Alternating
Sawtooth
Pattern**

Perspective

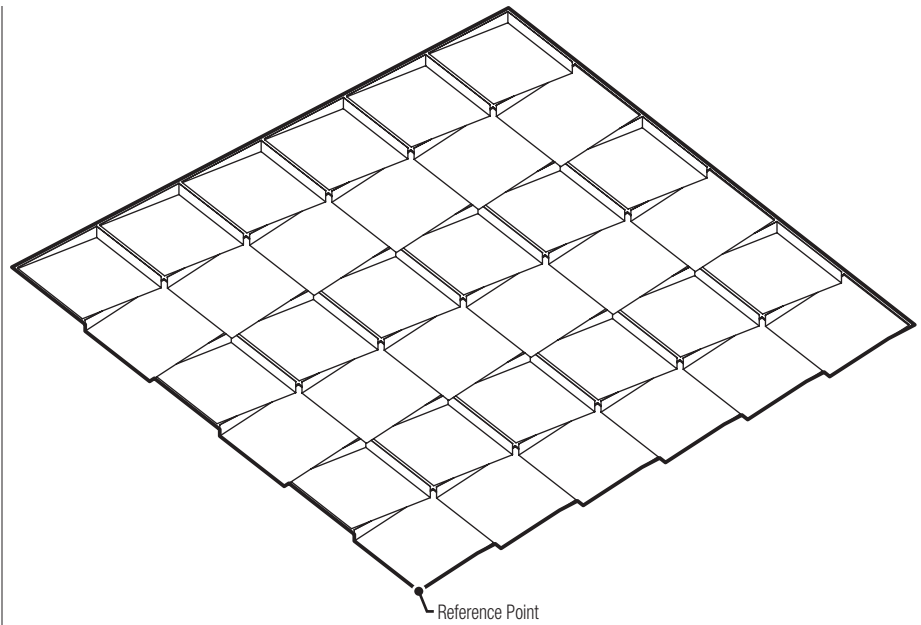

**Reflected
Ceiling Plan
Using GEOMETRIX
CAD Blocks**

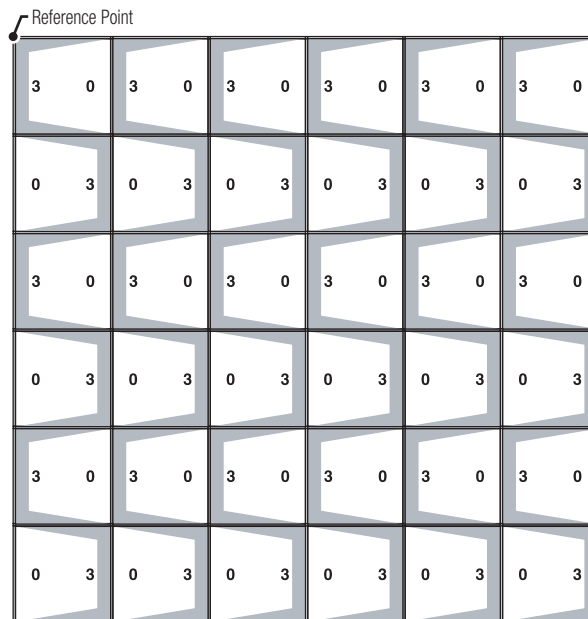

Design Concepts

Checkerboard Pattern Perspective

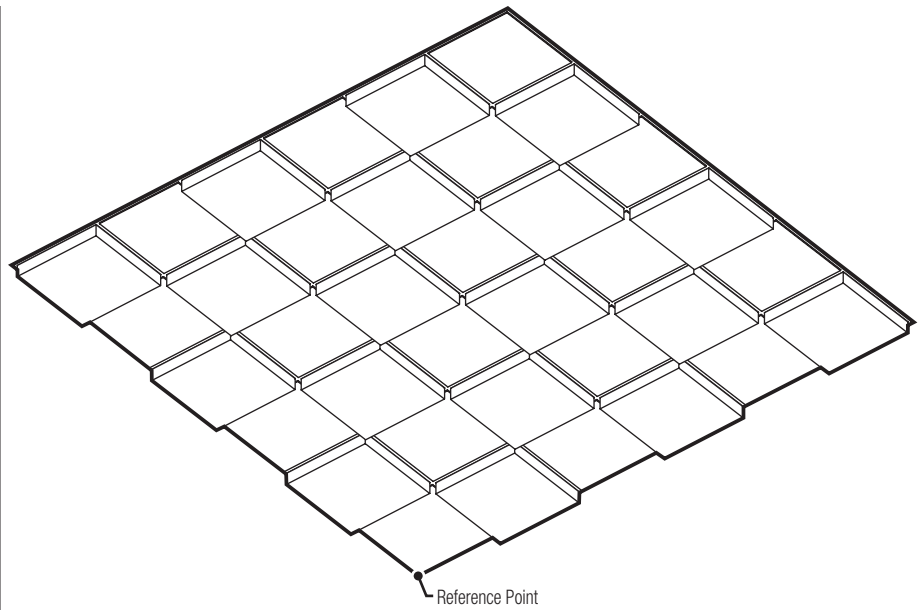

Reflected Ceiling Plan Using GEOMETRIX CAD Blocks

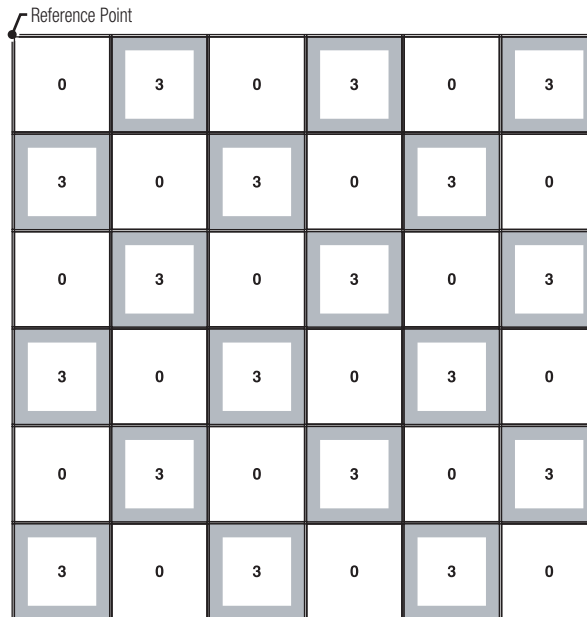

**Pinwheel
Pattern**

Perspective

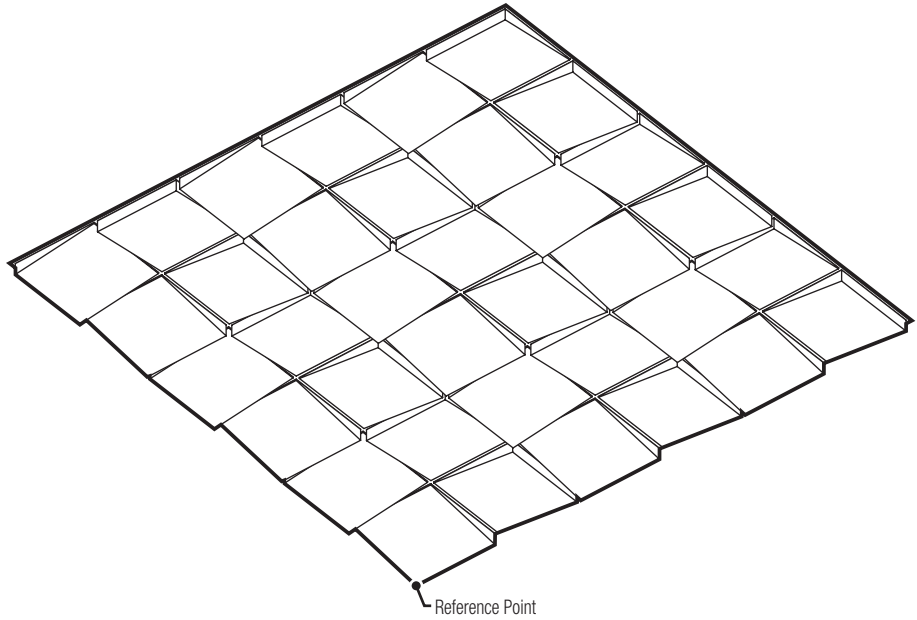

**Reflected
Ceiling Plan
Using GEOMETRIX
CAD Blocks**

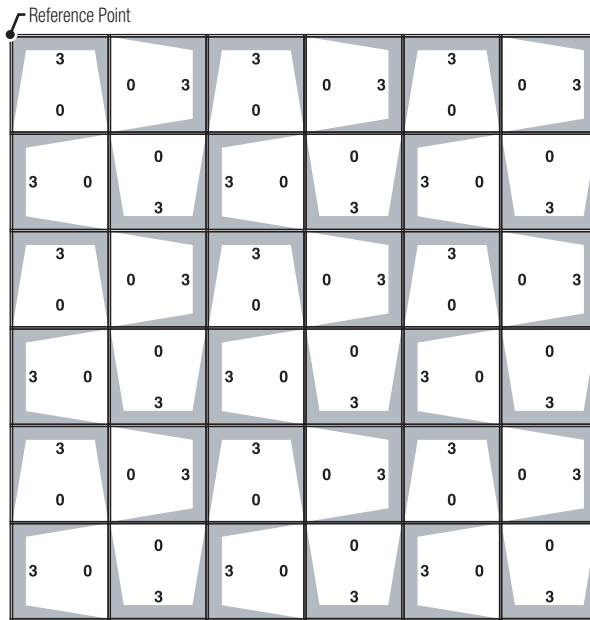

Design Concepts

**Undulating
Pattern**

Perspective

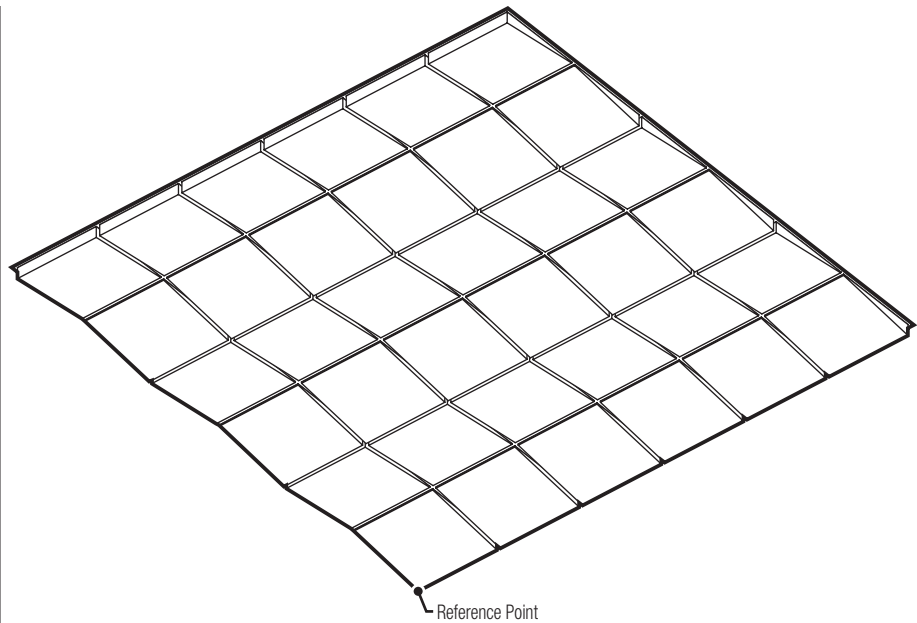

**Reflected
Ceiling Plan
Using GEOMETRIX
CAD Blocks**

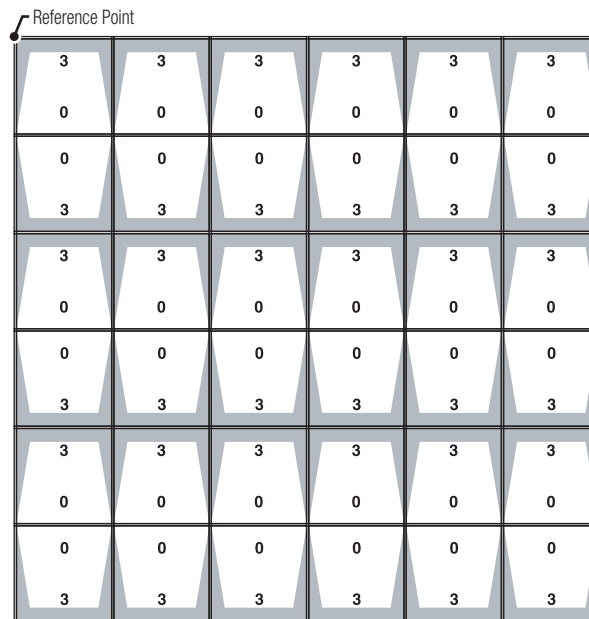

Random

Perspective

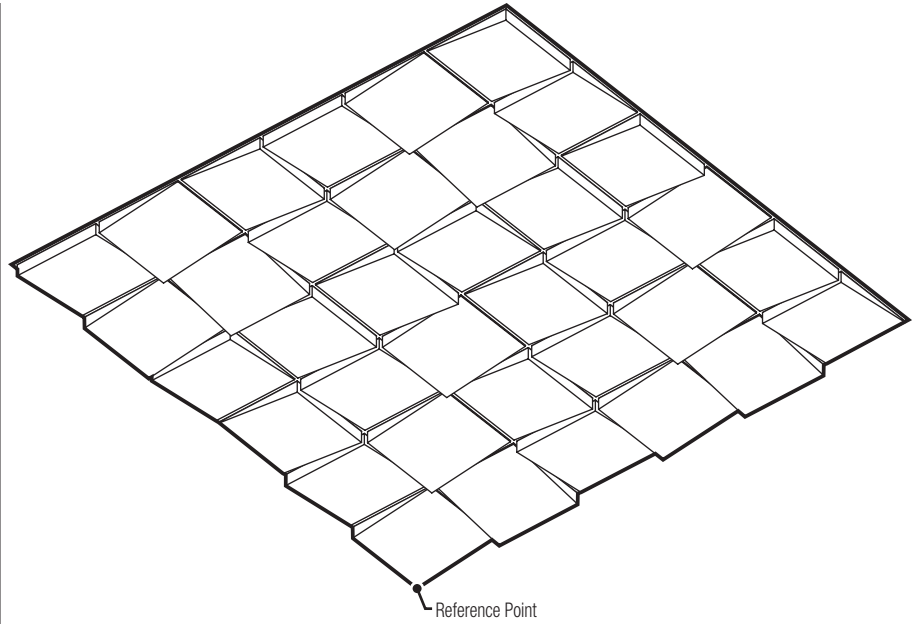

Reflected
Ceiling Plan
Using GEOMETRIX
CAD Blocks

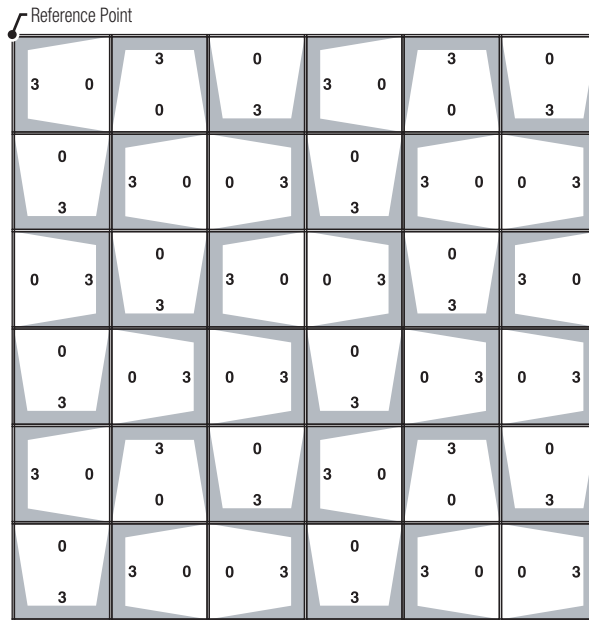

Application Guide

Specifications

Section 09514—Acoustical Metal Pan Ceilings

Part 1: General	1.1 Related Documents	A. Drawings and general provisions of the Contract, including General and Supplementary Conditions and Division 1 Specification Sections, apply to this Section.
	1.2 Summary	<p>A. This Section includes aluminum acoustical metal pans and exposed direct-hung suspension systems for ceilings.</p> <p>B. Related Sections include the following:</p> <ol style="list-style-type: none"> 1. Division 9 – Section 09250 – Gypsum Board 2. Division 9 – Section 09511 – Acoustical Panel Ceilings 3. Division 15 Sections – Mechanical 4. Division 16 Sections – Electrical <p>C. Products furnished, but not installed under this Section.</p>
	1.3 Definitions	<p>A. AC: Articulation Class.</p> <p>B. NRC: Noise Reduction Coefficient.</p> <p>C. Recycled Content: Average percentage based on weight of component materials. Material recovered or diverted from the solid waste stream, either during the manufacturing process (pre-consumer) or after consumer use (post-consumer).</p>
	1.4 Submittals	<p>A. Product Data: For each type of product indicated.</p> <p>B. Coordinate Drawings: Reflected ceiling plans drawn to scale and coordinating penetrations and ceiling-mounted items. Show the following:</p> <ol style="list-style-type: none"> 1. Ceiling suspension members. 2. Method of attaching hangers to building structure. 3. Ceiling-mounted items including lighting fixtures, diffusers, grilles, speakers, sprinklers, access panels, and special moldings. <p>C. Samples for Verification: For each component indicated and for each exposed finish required, prepared on Samples of size indicated below.</p> <ol style="list-style-type: none"> 1. Metal Pan: Manufacturer standard samples of each type, finish, color, pattern, and texture. Show pan edge profile. 2. Exposed Suspension System Members, Moldings, and Trim: Set of 12 inch long Samples of each type, finish, and color. <p>D. Product Test Reports: Based on evaluation of comprehensive tests performed by a qualified testing agency, for each acoustical panel ceiling and suspension system.</p> <ol style="list-style-type: none"> 1. UL Acoustical Compliance: For acoustical performance, each carton of material must carry Underwriter's Laboratory certification for AC (if applicable), CAC and NRC. 2. UL Suspension System Load Compliance: Manufacturer must certify that the metal suspension system is UL Classified to be load compliant per ASTM C635. For load compliance, each carton of main tees must carry Underwriter's Laboratory certification for load compliance. <p>E. Research/Evaluation Reports: For each acoustical panel ceiling and components.</p> <p>F. Maintenance Data: For finishes to include in maintenance manuals.</p>
	1.5 Quality Assurance	<p>A. Source Limitations for Acoustical Metal Pan Ceilings: Obtain each set of acoustical metal pans and exposed suspension systems from one source with resources to provide products of consistent quality in appearance, physical properties, and performance.</p> <p>B. Fire-Test-Response Characteristics: Provide acoustical metal pan ceilings with surface-burning characteristics complying with ASTM E 1264 for Class A materials as determined by testing identical products per ASTM E 84 by UL or another testing and inspecting agency acceptable to authorities having jurisdiction.</p> <p>C. Seismic Standard: Provide acoustical metal pan ceilings designed and installed to withstand the effects of earthquake motions according to the following:</p> <ol style="list-style-type: none"> 1. Standard for Ceiling Suspension Systems Requiring Seismic Restraint: Comply with ASTM E 580. 2. Cisca's Recommendations for Acoustical Ceilings: Comply with Cisca's "Recommendations for Direct-Hung Acoustical Tile and Lay-in Panel Ceilings—Seismic Zones 0-2."

		<ul style="list-style-type: none"> 3. CISCA's Guidelines for Systems Requiring Seismic Restraint: Comply with CISCA's "Guidelines for Seismic Restraint of Direct-Hung Suspended Ceiling Assemblies—Seismic Zones 3 & 4." 4. UBC Standard 25-2, "Metal Suspension Systems for Acoustical Tile and for Lay-in Panel Ceilings." <p>D. Pre-installation Conference: Conduct conference at Project site to comply with requirements in Division 1 Section "Project Management and Coordination."</p>
1.6 Delivery, Storage, and Handling	A.	Deliver acoustical metal pans, suspension system components, and accessories to Project site in original, unopened packages and store them in a fully enclosed, conditioned space where they will be protected against damage from moisture, humidity, temperature extremes, direct sunlight, surface contamination, and other causes.
1.7 Project Conditions	A.	<p>Environmental Limitations: Do not install acoustical metal pan ceilings until spaces are enclosed and weather-proof, wet work in spaces is complete and dry, work above ceilings is complete, and ambient temperature and humidity conditions are maintained at the levels indicated for Project when occupied for its intended use.</p> <ul style="list-style-type: none"> 1. Pressurized Plenums: Operate ventilation system for not less than 48 hours before beginning acoustical panel ceiling installation.
1.8 Coordination	A.	Coordinate layout and installation of acoustical metal pans and suspension system with other construction that penetrates ceilings or is supported by them, including light fixtures, HVAC equipment, fire-suppression system, and partition assemblies.
1.9 Extra Materials	A.	<p>Furnish extra materials described below that match products installed and that are packaged with protective covering for storage and identified with labels describing contents.</p> <ul style="list-style-type: none"> 1. Acoustical Metal Pans: Full-size units equal to 2.0 percent of quantity installed. 2. Suspension System Components: Quantity of each exposed component equal to 2.0 percent of quantity installed. 3. Hold-Down Clips: Equal to 2.0 percent of amount installed.
Part 2: Products	2.1 Manufacturers	<p>A. In other Part 2 articles where titles below introduce lists, the following requirements apply for product selection:</p> <ul style="list-style-type: none"> 1. Products: Subject to compliance with requirements, provide one of the products specified. 2. Manufacturers: Subject to compliance with requirements, provide products by the manufacturers specified.
	2.2 Acoustical Metal Ceiling Pans	<p>A. Acoustical Metal Pan Standard: Provide manufacturer's standard acoustical metal pans of configuration indicated that comply with ASTM E 1264 classifications as designated by types, acoustical ratings, and light reflectance, unless otherwise indicated.</p> <ul style="list-style-type: none"> 1. Mounting Method for Measuring NRC: Type E-400; plenum mounting in which face of test specimen is 15-3/4 inches away from test surface per ASTM E 795. <p>B. Sheet Metal Characteristics: For metal fabrications exposed to view in the completed Work, provide materials with smooth, flat surfaces without blemishes. Do not use materials with exposed pitting, seam marks, roller marks, roughness, stains, or discolorations.</p> <ul style="list-style-type: none"> 1. Aluminum Sheet: Roll-formed aluminum sheet, complying with ASTM B 209; alloy and temper recommended by aluminum producer and finisher for type of use and finish indicated. <p>C. Pan Fabrication: Manufacturer's standard units of size, profile, and edge treatment indicated, formed from metal indicated and finished to comply with requirements indicated.</p> <ul style="list-style-type: none"> 1. Lay-in Pans: Formed to set in exposed suspension grid. (Delete the following paragraph if non-perforated panels are used or sound-absorbing layer is not required.) <p>D. Sound-Absorbent Fabric Layer: Provide fabric layer, sized to fit concealed surface of pan, and consisting of [black], [white], nonwoven, nonflammable, sound-absorbent material with surface-burning characteristics for flame-spread index of 25 or less and smoke-developed index of 50 or less, as determined by testing per ASTM E 84.</p> <ul style="list-style-type: none"> 1. Bond fabric layer to panels in the factory with manufacturer's standard nonflammable adhesive.

Application Guide

Specifications

2.3 Aluminum Metal Pans for Acoustical Metal Pan Ceiling AMPC-[#]

- A. Products:
USG Interiors, LLC, [GEOMETRIX].
- B. Classification: Units complying with ASTM E 1264 for [Type VII, perforated aluminum facing (pan) with mineral- or glass-fiber-base backing] [Type XX, other types described as perforated aluminum facing (pan) units] [Type XX, other types described as nonperforated aluminum facing (pan) units] <Insert Type XX description>.
- 1. Pattern: [Perforation Pattern C375], [Perforation Pattern D250], [Perforation Pattern D375], [Perforation Pattern C062], [Perforation Pattern C062A].
- C. Pan Type: Lay-in pan.
- D. Pan Thickness: Not less than 0.020" minimum.
- E. Pan Edge Detail: [5/16" Reveal] [1-1/4" Reveal] [2-1/4" Reveal] [3-1/4" Reveal].
- F. Pan Profile Detail: [Flat] [Wedge] [Inside Wedge Corner] [Outside Wedge Corner].
- G. Pan Size: 24 by 24 inches.
- H. Pan Face Finish: Painted to match color indicated by product designation.
- I. Recycled Content: Not less than 90%.

2.4 Metal Suspension Systems

- A. Metal Suspension System Standard: Provide manufacturer's standard direct-hung metal suspension systems of types, structural classifications, and finishes indicated that comply with applicable requirements in ASTM C 635.
- B. Finishes and Colors, General: Comply with NAAMM's "Metal Finishes Manual for Architectural and Metal Products" for recommendations for applying and designating finishes. Provide manufacturer's standard factory-applied finish for type of system indicated.
- C. Attachment Devices: Size for five times the design load indicated in ASTM C 635, Table 1, "Direct Hung," unless otherwise indicated.
 - 1. Anchors in Concrete: Anchors of type and material indicated below, with holes or loops for attaching hangers of type indicated and with capability to sustain, without failure, a load equal to five times that imposed by ceiling construction, as determined by testing per ASTM E 488 or ASTM E 1512 as applicable, conducted by a qualified testing and inspecting agency.
 - a. Type: Postinstalled expansion anchors.
 - b. Type: Postinstalled adhesive anchors.
 - c. Corrosion Protection: Carbon-steel components zinc plated to comply with ASTM B 633, Class Fe/Zn 5 (0.005 mm) for Class SC 1 service condition.
 - d. Corrosion Protection: Stainless-steel components complying with ASTM F 593 and ASTM F 594, Group 1 alloy 304 or 316 for bolts; alloy 304 or 316 for anchor.
 - e. Corrosion Protection: Components fabricated from nickel-copper-alloy rods complying with ASTM B 164 for UNS No. N04400 alloy.
 - 2. Power-Actuated Fasteners in Concrete: Fastener system of type suitable for application indicated, fabricated from corrosion-resistant materials, with clips or other accessory devices for attaching hangers of type indicated, and with capability to sustain, without failure, a load equal to 10 times that imposed by ceiling construction, as determined by testing per ASTM E 1190, conducted by a qualified testing and inspecting agency.
- D. Wire Hangers, Braces, and Ties: Provide wires complying with the following requirements:
 - 1. Zinc-Coated Carbon-Steel Wire: ASTM A 641/A 641M, Class 1 zinc coating, soft temper.
 - 2. Nickel-Copper-Alloy Wire: ASTM B 164, nickel-copper-alloy UNS No. N04400.
 - 3. Size: Select wire diameter so its stress at three times hanger design load (ASTM C 635, Table 1, "Direct Hung") will be less than yield stress of wire, but provide not less than [0.106-inch] [0.135-inch] diameter wire.
- E. [Hanger Rods] [Flat Hangers]: Mild steel, zinc coated or protected with rust-inhibitive paint.

- F. Angle Hangers: Angles with legs not less than 7/8 inch wide; formed with 0.04-inch thick, galvanized steel sheet complying with ASTM A 653/A 653M, G90 coating designation; with bolted connections and 5/16-inch diameter bolts.
 - G. Seismic Struts: Manufacturer's standard compression struts designed to accommodate seismic forces.
 - H. Seismic Clips: Manufacturer's standard seismic clips designed and spaced to secure acoustical panels in-place.
 - I. Hold-Down Clips: Where indicated, provide manufacturer's standard hold-down clips spaced 24 inches o.c. on all cross tees.
 - J. Exposed Metal Edge Moldings and Trim: Provide exposed members as indicated or required [to comply with seismic requirements of authorities having jurisdiction,] to conceal edges of and penetrations through ceiling, to conceal edges of pans and runners, for fixture trim and adapters, for fascia at changes in ceiling height, and for other conditions; of metal and finish matching acoustical metal pan ceiling units, unless otherwise indicated.
1. For Circular Penetrations of Ceiling: Fabricate edge moldings to diameter required to fit penetration exactly.

**2.5
Metal Suspension
System for
Acoustical
Metal Pan Ceiling**

- A. Products:
 1. USG Interiors, LLC, Donn [DX] [DXT] [DXF] [DXFF] suspension system.
- B. Wide-Face, Capped, Double-Web, Steel Suspension System: Main and cross runners roll formed from cold-rolled steel sheet, prepainted, electrolytically zinc coated, or hot-dip galvanized according to ASTM A 653/A 653M, not less than G30 coating designation, with prefinished 15/16-inch wide metal caps on flanges.
 1. Structural Classification: [Intermediate] [Heavy]-duty system.
 2. End Condition of Cross Runners: Override (stepped) type.
 3. Face Design: Flat, flush.
 4. Cap Material: [Steel] [Aluminum] cold-rolled sheet.
 5. Cap Finish: [Painted white] [Painted in color as selected from manufacturer's full range] [Painted to match color of acoustical unit] [Plated with metallic finish, as selected from manufacturer's full range].
- C. Narrow-Face, Capped, Double-Web, Steel Suspension System: Main and cross runners roll formed from cold-rolled steel sheet, prepainted, electrolytically zinc coated, or hot-dip galvanized according to ASTM A 653/A 653M, not less than G30 coating designation, with prefinished 9/16-inch wide metal caps on flanges.
 1. Structural Classification: [Intermediate] [Heavy]-duty system.
 2. End Condition of Cross Runners: Override (stepped) type.
 3. Face Design: Flat, flush.
 4. Cap Material: [Steel] cold-rolled sheet.
 5. Cap Finish: [Painted white] [Painted in color as selected from manufacturer's full range] [Painted to match color of acoustical unit] [Plated with metallic finish, as selected from manufacturer's full range].
- D. Narrow-Face, Uncapped, Double-Web, Steel Suspension System: Main and cross runners roll formed from cold-rolled steel sheet, prepainted, electrolytically zinc coated, or hot-dip galvanized, to produce structural members with 9/16-inch wide faces.
 1. Structural Classification: [Intermediate] [Heavy]-duty system.
 2. Face Design: [With 1/8-inch wide, slotted, box-shaped flange] [With 1/4-inch wide, slotted, box-shaped flange].
 3. Face Finish: Painted [white] [in color as selected from manufacturer's full range] [to match color indicated by manufacturer's designation] [to match color of acoustical unit].
 4. Reveal Finish: Painted [white] [black].

Application Guide

Specifications

2.6 Metal Edge Moldings and Trim

- A.** Manufacturers:
 - 1. USG Interiors, LLC
- B.** Roll-Formed Sheet-Metal Edge Moldings and Trim: Type and profile indicated or, if not indicated, manufacturer's standard moldings for edges and penetrations that fit acoustical panel edge details and suspension systems indicated; formed from sheet metal of same material, finish, and color as that used for exposed flanges of suspension system runners.
 - 1. For lay-in panels with reveal edge details, provide stepped edge molding that forms reveal of same depth and width as that formed between edge of panel and flange at exposed suspension member.
 - 2. For circular penetrations of ceiling, provide edge moldings fabricated to diameter required to fit penetration exactly.
 - 3. For narrow-face suspension systems, provide suspension system and manufacturer's standard edge moldings that match width and configuration of exposed runners.
- C.** COMPASSO Suspension System Trim:
 - 1. COMPASSO Trim: [2-1/4 inch] [4 inch] [6 inch] [8 inch] wide face, 9/16 inch horizontal legs with hems formed for attachment to the COMPASSO mounting clip; commercial quality cold-rolled 24-gauge steel, factory finished in [baked polyester enamel paint finish], [color], painted [on exposed face] [all around – 360°].
 - 2. Splice plate: Steel in finish to match trim pans; formed for snap-fit into [2-1/4 inch] [4 inch] [6 inch] [8 inch] pan ends.
 - 3. Attachment clips: Hot-dipped steel in [galvanized finish] [finish to match pans] formed for snap-fit into [2-1/4 inch] [4 inch] [6 inch] [8 inch] pan attached to DONN [DX] [DXT] [DXF] [DXFF] suspension system members.
 - 4. 90° Corner Trim Pieces: To match COMPASSO trim.

2.7 Acoustical Sealant

- A.** Products:
 - 1. Acoustical Sealant for Exposed and Concealed Joints:
 - a. United States Gypsum Co.; SHEETROCK Acoustical Sealant.
 - 2. Acoustical Sealant for Concealed Joints:
 - a. Tremco, LLC; Tremco Acoustical Sealant.
- B.** Acoustical Sealant for Exposed and Concealed Joints: Manufacturer's standard nonsag, paintable, nonstaining latex sealant complying with ASTM C 834 and effective in reducing airborne sound transmission through perimeter joints and openings in building construction as demonstrated by testing representative assemblies according to ASTM E 90.
- C.** Acoustical Sealant for Concealed Joints: Manufacturer's standard nondrying, nonhardening, nonskinning, nonstaining, gunnable, synthetic-rubber sealant recommended for sealing interior concealed joints to reduce airborne sound transmission.

2.8 Finishes, General

- A.** Comply with NAAMM's "Metal Finishes Manual for Architectural and Metal Products" for recommendations for applying and designating finishes.
- B.** Appearance of Finished Work: Variations in appearance of abutting or adjacent pieces are acceptable if they are within one-half of the range of approved Samples. Noticeable variations in the same piece are not acceptable. Variations in appearance of other components are acceptable if they are within the range of approved Samples and are assembled or installed to minimize contrast.

2.9 Aluminum Finishes

- A.** Finish designations prefixed by AA comply with the system established by the Aluminum Association for designating aluminum finishes.
- B.** Color-Coated Finish: Manufacturer's standard baked paint complying with coating manufacturer's written instructions for surface preparation, pretreatment, application, baking, and minimum dry film thickness.

**Part 3:
Execution**

**3.1
Examination**

- A.** Examine substrates, areas, and conditions, including structural framing to which acoustical panel ceilings attach or abut, with Installer present, for compliance with requirements specified in this and other Sections that affect ceiling installation and anchorage and with requirements for installation tolerances and other conditions affecting performance of acoustical panel ceilings.
- B.** Proceed with installation only after unsatisfactory conditions have been corrected.

**3.2
Preparation**

- A.** Measure each ceiling area and establish layout of acoustical panels to balance border widths at opposite edges of each ceiling. Avoid using less-than-half-width panels at borders, and comply with layout shown on reflected ceiling plans.

**3.3
Installation,
General**

- A.** General: Install acoustical panel ceilings to comply with ASTM C 636 and seismic requirements indicated, per manufacturer's written instructions and CISCA's "Ceiling Systems Handbook."
- B.** Suspend ceiling hangers from building's structural members and as follows:
 - 1.** Install hangers plumb and free from contact with insulation or other objects within ceiling plenum that are not part of supporting structure or of ceiling suspension system.
 - 2.** Splay hangers only where required to miss obstructions; offset resulting horizontal forces by bracing, countersplaying, or other equally effective means.
 - 3.** Splay hangers only where required and, if permitted with fire-resistance-rated ceilings, to miss obstructions; offset resulting horizontal forces by bracing, countersplaying, or other equally effective means.
 - 4.** Where width of ducts and other construction within ceiling plenum produces hanger spacings that interfere with location of hangers at spacings required to support standard suspension system members, install supplemental suspension members and hangers in form of trapezes or equivalent devices. Size supplemental suspension members and hangers to support ceiling loads within performance limits established by referenced standards and publications.
 - 5.** Secure wire hangers to ceiling suspension members and to supports above with a minimum of three tight turns. Connect hangers directly either to structures or to inserts, eye screws, or other devices that are secure and appropriate for substrate and that will not deteriorate or otherwise fail due to age, corrosion, or elevated temperatures.
 - 6.** Secure flat, angle, channel, and rod hangers to structure, including intermediate framing members, by attaching to inserts, eye screws, or other devices that are secure and appropriate for both structure to which hangers are attached and type of hanger involved. Install hangers in a manner that will not cause them to deteriorate or fail due to age, corrosion, or elevated temperatures.
 - 7.** Do not support ceilings directly from permanent metal forms or floor deck. Fasten hangers to cast-in-place hanger inserts, postinstalled mechanical or adhesive anchors, or power-actuated fasteners that extend through forms into concrete.
 - 8.** Do not attach hangers to steel deck tabs.
 - 9.** Do not attach hangers to steel roof deck. Attach hangers to structural members.
 - 10.** Space hangers not more than 48 inches o.c. along each member supported directly from hangers, unless otherwise indicated; provide hangers not more than 8 inches from ends of each member.
- C.** Secure bracing wires to ceiling suspension members and to supports with a minimum of four tight turns. Suspend bracing from building's structural members as required for hangers, without attaching to permanent metal forms, steel deck, or steel deck tabs. Fasten bracing wires into concrete with cast-in-place or postinstalled anchors.

Application Guide

Specifications

- D. Install edge moldings and trim of type indicated at perimeter of acoustical ceiling area and where necessary to conceal edges of acoustical panels.
 - 1. Apply acoustical sealant in a continuous ribbon concealed on back of vertical legs of moldings before they are installed.
 - 2. Screw attach moldings to substrate at intervals not more than 16 inches o.c. and not more than 3 inches from ends, leveling with ceiling suspension system to a tolerance of 1/8 inch in 12 feet Miter corners accurately and connect securely.
 - 3. Do not use exposed fasteners, including pop rivets, on moldings and trim.
- E. Install suspension system runners so they are square and securely interlocked with one another. Remove and replace dented, bent, or kinked members.
- F. Cut acoustical metal pan units for accurate fit at borders and at interruptions and penetrations by other work through ceilings. Stiffen edges of cut units as required to eliminate evidence of buckling or variations in flatness exceeding referenced standards for stretcher-leveled metal sheet.
- G. Install acoustical metal pans in coordination with suspension system and exposed moldings and trim.
 - 1. For lay-in reveal-edge pans on suspension system runners, install pans with bottom of reveal in firm contact with top surface of runner flanges.
 - 2. For lay-in reveal-edge pans on suspension system members with box-shaped flanges, install pans with reveal surfaces in firm contact with suspension system surfaces and panel faces flush with bottom face of runners.
 - 3. Align joints in adjacent courses to form uniform, straight joints parallel to room axis in both directions, unless otherwise indicated.
 - 4. Install directionally patterned or textured metal pans in directions indicated.
 - 5. Install sound-absorbent fabric layers in perforated metal pans.

3.4 Cleaning

- A. Clean exposed surfaces of acoustical metal pan ceilings, including trim and edge moldings after removing strippable, temporary protective covering, if any. Comply with manufacturer's written instructions for stripping of temporary protective covering, cleaning, and touchup of minor finish damage. Remove and replace ceiling components that cannot be successfully cleaned and repaired to permanently eliminate evidence of damage, including dented and bent units.

Energy and Style



Technical Service
800 USG.4YOU

Web Site
usg.com

Samples/Literature E-mail
samplit@usg.com

Samples/Literature/Fax
888 874.2348

Customer Service
800 950.3839

Note

All products described here may not be available in all geographic markets. Consult your local sales office or representative for information.

Trademarks

The following trademarks used herein are owned by USG Interiors, LLC: CENTRICITEE, DONN, DX, FINELINE, GEOMETRIX, USG.

Notice

We shall not be liable for incidental and consequential damages, directly or indirectly sustained, nor for any loss caused by application of these goods not in accordance with current printed instructions or for other than the intended use. Our liability is expressly

limited to replacement of defective goods. Any claim shall be deemed waived unless made in writing to us within thirty (30) days from date it was or reasonably should have been discovered.

SAFETY FIRST!

Follow good safety and industrial hygiene practices during handling and installation of all products and systems. Take necessary precautions and wear the appropriate personal protective equipment as needed. Read material safety data sheets and related literature on products before specification and/or installation.

