

Acoustical Ceiling Design & Application

9



The development of suspended ceiling systems in the early 1950s produced a shift in thinking about the function of a ceiling in construction. A ceiling simply had been regarded as a single-plane, fire-protective, finished element overhead. Suddenly, with the introduction of a suspension system, the ceiling also offered access to plumbing, electrical and mechanical components in overhead runs.

Today's suspended ceiling systems offer even more advantages for building construction, including a range of acoustical control options, fire protection, esthetic appearance, flexibility in lighting and HVAC delivery, budget control and optional use of overhead space.

Note that various organizations provide information and recommended standards or tolerances for installing ceiling suspension systems and acoustical panel and tile products. See pages 435 and 442 in the Appendix for information about standards and tolerances.

For instructions on the safe use of ceiling suspension systems and acoustical panel and tile products, see Chapter 13, Safety Considerations, Material Handling.

Suspended Acoustical Ceiling Products

Key components for suspended acoustical ceilings are suspension grid and acoustical panels. Composition of each can vary depending on the end-use application. Acoustical tile (305 x 305 mm (12" x 12")) is also an acoustical ceiling product, but unlike larger panels (610 x 610 mm (24" x 24") and larger), the tiles are typically glued or stapled to an existing ceiling surface. They also may be assembled like puzzle pieces on a special concealed grid suspension system.

Grid Systems

CGC offers five primary grid systems. The systems all perform the same function of suspending panels in a single plane from the overhead building structure. Differences are in the design and compatibility with certain styles of panels, and the resulting appearance of the finished ceiling.

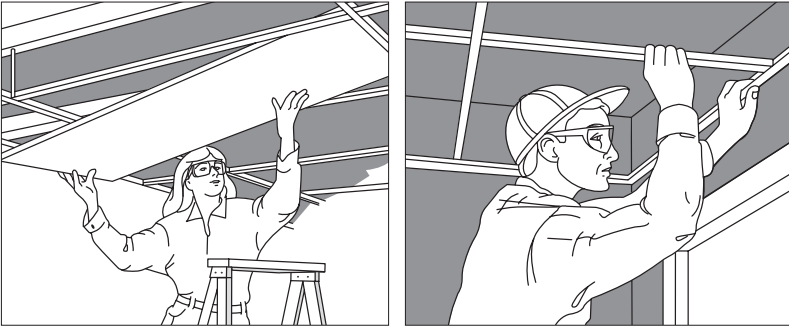

Acoustical suspension (grid) systems from CGC are fast and easy to install. Acoustical panels simply drop into the suspension system.

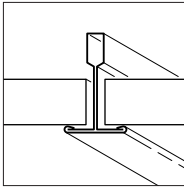

DONN DX

DONN DX Suspension System is an exposed 24 mm (15/16") wide face grid. It is the most commonly used suspension system. Note that exposed face grid products are typically differentiated by the width of the exposed portion and/or by reveals in the exposed portion.

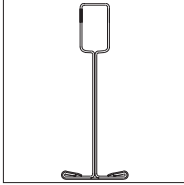

DONN CENTRICITEE

DONN CENTRICITEE Suspension System is an exposed 14 mm (9/16") wide face grid. The narrower face fits reveal-edge panels, and square-edge panels up to 610 mm x 610 mm (24" x 24").

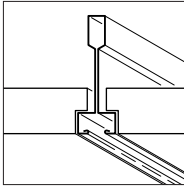

DONN FINELINE

DONN FINELINE Suspension System is an exposed 14 mm (9/16") slotted grid. It features either a 6.4 mm (1/4") or 3.2 mm (1/8") slot in the center of the exposed face that adds an attractive feature. The face of this grid fits flush with the face of reveal-edge panels. Mitered intersections provide a clean, tailored appearance.

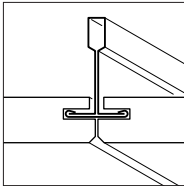

DONN DX Concealed

DONN DX Concealed Suspension System is designed for use with kerfed ceiling tile. In this application, the 24 mm (15/16") grid surface is completely concealed by the tile.

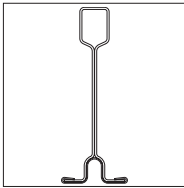

DONN MERIDIAN DXM

DONN MERIDIAN DXM. The aesthetics of more expensive bolt-slot grid with the function and utility of exposed grid.

These grid systems are available either fire-rated or non-rated, with the exception of MERIDIAN, which is only non-rated. Fire-rated versions are made with a special fire expansion relief notch in each main tee to compensate for the significant expansion of the grid if exposed to the extreme temperatures of a fire. This expansion relief notch absorbs the expansion to keep the grid modules intact, thus preventing ceiling panels from falling out.

In addition to the five primary grid systems, CGC offers a range of special function products for controlled environment applications as follows:

DONN AX, a noncorrosive aluminum 24 mm (15/16") exposed grid system, ideal for high-humidity environments or wet-cleaned areas.

DONN CE, a 38 mm (1-1/2") exposed, pre-gasket, heavy duty grid system, designed for controlled environment rooms that require a clean, particulate-free, sealed ceiling system.

DONN ZXA/ZXLA, a 24 mm (15/16") exposed, hot-dipped galvanized grid system with an aluminum cap, ideal for use in exterior and severe environments.

DONN DXSS, a 24 mm (15/16") Type 316 stainless steel grid system, designed for industrial and other extreme environments.

Structural Implications

The grid system becomes a structural component in the ceiling. It must carry the loads of lighting, air distribution and ceiling panels in a safe manner. Through the hanger wires that suspend the ceiling, these loads are transferred to the building structure. The performance of the grid system is dependent upon the integrity of the product as well as its proper installation.

There are standards that must be met in order to assure the integrity of the installed ceiling. ASTM Standard C-635 governs the structural and quality standards of the grid. ASTM Standard C-636 provides for proper installation to assure the load-carrying and general structural integrity of the ceiling. Load compliance of CGC grid products is certified by Underwriters Laboratories Inc., per ASTM C635.

Ceiling Panels

The most commonly used panel sizes measure 610 x 610 mm (2' x 2') or 610 x 1220 mm (2' x 4') and are typically 15.9 mm (5/8") or 19 mm (3/4") thick. Although this is the nominal reference, the dimensions actually refer to the module size of the ceiling. Panel sizes, in fact, are 6 mm (1/4") less than the module size in both directions.

610 x 1220 mm (2' x 4') RADAR Illusion Eight/12 panel (left) uses face cuts to simulate smaller grid modules. Lightly textured 610 x 610 mm (2' x 2') Frost pattern panel is available with square-cut, Shadowline-cut or Fineline-cut edges.

CGC offers a full line of acoustical panels to achieve any functional or esthetic need. Selection can be based on varied parameters—texture, budget, acoustical performance, functional requirements, color, etc. For a complete guide, call your CGC representative, 1-800-565-6607, and ask for catalog information, or visit the CGC web site at www.cgcinc.com.

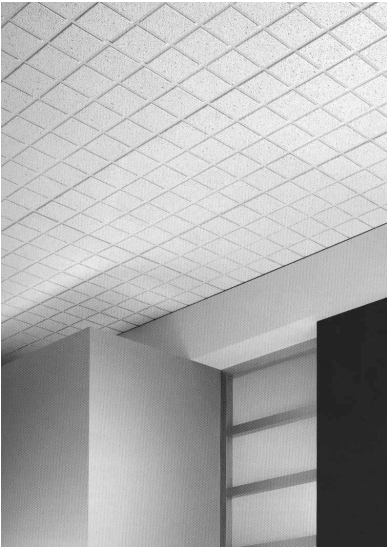

Ceiling Panel Types and Manufacturing Processes

| Manufacturing Process | Product Pattern | Features/Benefits |
|-----------------------------|---|---|
| X-Technology Ceiling Panels | ECLIPSE <i>CLIMAPLUS</i> MAPS <i>CLIMAPLUS</i> MILLENNIA <i>CLIMAPLUS</i> ORION 210 <i>CLIMAPLUS</i> ORION 270 <i>CLIMAPLUS</i> | <p>X-Technology Acoustical Ceiling Panels are manufactured using a unique process that maximizes sound and environmental performance, and provides the following:</p> <ul style="list-style-type: none"> • Smooth lightly textured surface with high noise reduction coefficient (NRC) and ceiling attenuation class (CAC) performance • Superior sag resistance and outstanding dimensional stability • Easy maintenance—surface cleans easily with soft brush or vacuum • Applications—Hotels, office and conference areas, transportation terminals, reception and lobby areas, room-to-room privacy areas, high sound absorbancy areas |
| Cast Ceiling Panels | BRIO <i>CLIMAPLUS</i> "F" FISSURED FRESCO <i>CLIMAPLUS</i> FROST FROST <i>CLIMAPLUS</i> GLACIER SANDRIFT <i>CLIMAPLUS</i> SUMMIT <i>CLIMAPLUS</i> | <p>Cast ceiling panels are made with a process that enhances the surface appearance, orients fibers for excellent sound absorption and durability, and provides the following:</p> <ul style="list-style-type: none"> • Attractive surface appearance plus high noise reduction coefficients (NRC) • Clear-through color masks nicks and scratches • Long-lasting, abuse resistant surface • Foil backing acts as a sound barrier and resists "breathing" (air passing through the surface), so surface stays cleaner longer. ClimaPlus cast products have a special backing to provide superior sag resistance • Easy maintenance—surface cleans easily with soft brush or vacuum • Applications—Traffic areas, conference/speech privacy areas, hospitality areas, entertainment, retail stores |
| Water-Felted | Aspen ASTRO <i>CLIMAPLUS</i> Fissured Olympia Micro <i>CLIMAPLUS</i> Pebbled <i>CLIMAPLUS</i> RADAR RADAR <i>CLIMAPLUS</i> ROCK FACE <i>CLIMAPLUS</i> Touchstone <i>CLIMAPLUS</i> | <p>Water-felted ceiling panels are manufactured by a process that orients mineral fibers for excellent sound attenuation and provides the following:</p> <ul style="list-style-type: none"> • Good ceiling attenuation class (CAC) performance • Available in a variety of surface textures • Surface of panel has perforations to aid in sound absorption • Easy maintenance—surface cleans easily with soft brush or vacuum • Applications—General purpose areas, texture/light-sensitive areas, high design areas |

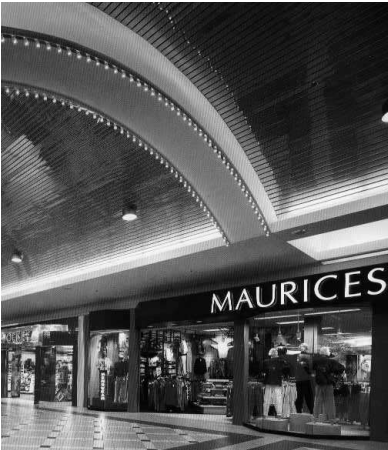

Examples of specialty ceilings include PARALINE (left) and GEOMETRIX (right) Ceilings.

Ceiling Panel Types and Manufacturing Processes (continued)

| Manufacturing Process | Product Pattern | Features/Benefits |
|--------------------------------|---|--|
| Fiberglass | Halcyon <i>CLIMAPLUS</i> Premier Hi-Lite <i>CLIMAPLUS</i> Premier Nubby <i>CLIMAPLUS</i> | Fiberglass panels offer superior sound control performance and provide the following: · High noise reduction coefficients (NRC) · Light weight · Extraordinary ease of maintenance—Premier Hi-Lite vinyl surface is scrubbable · Applications—Open floor plans, retail stores, gymnasiums and auditoriums, conference rooms and executive offices |
| Gypsum | CLEAN ROOM SHEETROCK Brand Gypsum Lay In Panels, <i>ClimaPlus</i> SHEETROCK Brand Gypsum Lay In Panels, <i>ClimaPlus</i> , Vinyl Faced SHEETROCK Brand Gypsum Lay In Panels, <i>ClimaPlus</i> , Natural Paper-Faced | SHEETROCK Brand Gypsum Lay In Panels, <i>CLIMAPLUS</i> all have a gypsum core and feature the <i>CLIMAPLUS</i> designation and provide the following: · Superior fire protection · Extraordinary dimensional stability · Exceptional foundation for added treatments/processes · Applications— Clean rooms Food preparation areas Mobile conveyances |
| Metal/Cast Plaster Specialties | See Below | In addition to conventional acoustical suspension systems, CGC offers many innovative specialty solutions for use in high-visibility spaces such as lobbies, retail environments, restaurants, entertainment complexes or any space where dramatic focus is important. The company has pioneered affordable and installable "systematized" metal and "curvalinear" products such as the following: |

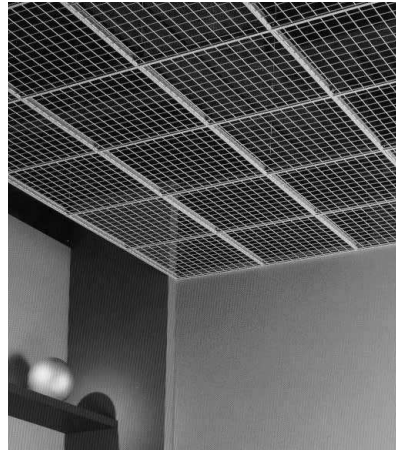

Unusual ceiling looks can be achieved with **QUADRA** Coffered Frames (left) and **WireWORKS** Wire Mesh Grid (right).

Ceiling Panel Types and Manufacturing Processes (continued)

| Manufacturing Process | Product Pattern | Features/Benefits |
|------------------------|-----------------|--|
| Cast Plaster | CADRE | Fiber reinforced cast gypsum panels offer the look of classic coffered architecture with complete accessibility to above-ceiling utilities. Designs include Contemporary, Historical, Executive and Concepts. |
| | QUADRA | Four-sided coffer frames give the appearance of moulded plaster with accessibility and sound control. |
| Roll Forming | CURVATURA | Imaginative ceiling system uses curved metal to enable free-flowing, three-dimensional designs that offer unique combinations of shape and texture. |
| | GRIDWARE | Open-cell suspension system comprised of main tees and cross tees. |
| | PARALINE | Decorative and functional linear metal ceiling system. |
| Pre-Formed Plastic | BILLO | BILLO™ 3-dimensional 2'x2' pre-formed LEXAN™ panels install into standard (15/16") and narrow (9/16") profile suspension systems. One simple panel shape allows for endless pattern possibilities. |
| | TOPO | The TOPO™ 3-Dimensional System consists of pre-formed LEXAN® infill panels installed into a curved, color-coordinated DOWN® Brand Topo Suspension System to create unique ceiling topographies. |
| Metal Stamping/Forming | COMPASSO | Metal suspension trim allows the creation of free-form ceiling islands or fascias incorporating any standard DOWN grid and CGC Interiors panel. |
| | CELEBRATION | Metal ceiling panels produce a contemporary ceiling surface, by snapping into DOWN FINELINE suspension and concealing the grid. |
| | GEOMETRIX | GEOMETRIX™ Metal Ceiling Panels are 3-dimensional, lightweight aluminum panels that lend unique perspective and unexpected dimension to ceiling space. Offered in a variety of designs and in varying depths, the panels install easily into 14 mm (9/16") narrow-profile and 24 mm (15/16") standard suspension systems |
| | PANZ | Standard steel or aluminum panels provide durability, accessibility, easy maintenance and sound control. |
| Welded Assembly | WireWORKS | Open-cell ceiling solution of powder-coated wire mesh that is compatible with GRIDWARE Ceiling System, COMPASSO Suspension Trim |

In addition, CGC can provide a variety of custom metal ceilings as design solutions.

Design Considerations for Suspended Acoustical Ceilings

The modern suspended acoustical ceiling makes both a functional as well as an esthetic contribution to overhead space. Selection of the ceiling that's right for a particular application requires careful consideration of a number of factors.

Function vs. Esthetics

Functional considerations include acoustical performance, durability, accessibility to the plenum, etc. Esthetics, on the other hand address texture, light enhancement, design, configuration and the like. Most often, both parameters can be met with a single system. Occasionally, however, one or both parameters must be compromised to accommodate the other.

Budget

Depending on the type of space, a larger or smaller percentage of the overall interior budget will be allocated for the ceiling system. If the ceiling simply needs to close off the plenum, without regard to looks, special functions, or acoustical performance, very inexpensive grid and tile products will be employed. "High End" applications, such as hotel lobbies, reception areas or top quality retail establishments command more attention and require greater budgets.

Acoustical Requirements

Acoustical performance sometimes is the primary criterion, especially in open plan spaces where conversations lose privacy and people can be disrupted in adjacent areas. Articulation Class (AC) is the most important factor in a ceiling designed for an open office, and the most cost-effective material for maximum sound absorption is fiber glass. (See product selections, pages 271-273.) These products perform at 0.75 NRC to 0.95 NRC range, and 180 to 200 AC range. Other products in the cast and X-technology lines offer similar NRC and AC ratings and are much more attractive.

If the acoustical objective is to attenuate or contain sound to the area of origin, hard-surfaced panels such as gypsum or metal face panels will do a better job. These products have CAC ratings as high as 45.

Purpose of the Space

Sound control typically is the most prominent purpose for ceiling selection, and the panels chosen for the sake of appearance then come from the selection that meets the acoustical criteria. There are times, however, when appearance criteria can far outweigh acoustical needs. CGC offers several ceiling options for esthetic appearance if acoustical control value is of secondary importance.

For example, in a restaurant a designer may want to incorporate the sophisticated high-tech look that can be offered by the CURVATURA Ceiling System, including the system's 3-dimensional vaulted or wavy ceiling designs. It can incorporate metal panels or, for some sound control, poly-bagged fiberglass overlays. COMPASSO Trim systems can provide islands of overhead sound absorption, or be left with open grid.

If acoustical control remains a key consideration, there are several options for attaining it. One is to install a standard acoustical ceiling above the focal point ceilings. Another option for localized sound control is to use perforated metal panels with floppy poly-bagged fiber glass inserts above the panels. In any case, the trade-offs need to be carefully evaluated.

CURVATURA Ceiling System



Selection Criteria

While function and esthetics are important, there are other selection criteria, including durability, installed cost, textures, colors, type of grid system, fire ratings and cleanability/scrubbability. Of course, the reliability of the supplier and manufacturer is among the best reasons to select ceiling systems from CGC.

CGC catalog and data sheets provide information about each of these selection criteria in an easy-to-use, easy-to-compare format.

Step-By-Step Ceiling Design

Three simple steps can guide specifiers to the ceiling selection of their choice. It's as easy as one, two, three.

1. Find the predominant selection criteria in CGC literature (CSC2014) or in the electronic catalogue. These pages are designed to narrow the search to products that apply. The selectors include acoustics, price or budget, color, textures, etc. The products that survive the screening can be evaluated in greater detail by going to their product pages.
2. Every product in each selector is described by its most common trade name. Information about things like tile and panel sizes, thickness, NRC values, fire rated designs, and color availability is provided to further narrow down the product choice.
3. Additional technical information is readily available for all products. Each product has a complete Technical Data and Specification Guide which is available by calling (800) 565-6607. These guides give

important additional information such as installation details, application information, structural load carrying information and performance data on air handling or lighting where appropriate. More complex products such as CURVATURA Ceiling System or COMPASSO Trim System, offer complete design portfolios to aid in the design and specification process. As the name implies, the Technical Data and Specification Guides have complete three-part specifications for easy inclusion into project specs. The electronic catalogue will allow you to produce detailed specifications for chosen products.

Standards for Suspended Acoustical Ceilings

The most common source for voluntary standards is the American Society for Testing and Materials (ASTM). ASTM is a not-for-profit organization that provides a forum for industry, consumer and regulatory body representatives, as well as other interested parties, to meet on a common ground and develop standards for products, installations and product testing methods. See the Appendix for explanations of the various ASTM Standards.

Product Specifications for Suspended Acoustical Ceiling Systems

Project specifications for the domestic building industry have almost entirely become coordinated with the use of standardized, organized systems for writing project manuals and specifications. Both the Royal Architectural Institute of Canada (RAIC) and the Construction Specifications Canada (CSC) promote specification standardization. CSC developed MASTERFORMAT as the guideline in its Manual of Practice for a complete system of construction documentation and also promotes the use of The National Master Specification (NMS).

Standard construction documents, particularly project and product specifications, streamline the bidding process while defining product and project quality. The project manual includes bid forms, contract conditions, drawings and specifications, addenda and modifications.

Sound Control

Acoustical sound control performance characteristics are referenced in three different ways: Noise Reduction Coefficient (NRC), Ceiling Attenuation Class (CAC) and Articulation Class (AC). These characteristics are expressed as ratings that can be used to compare products. See the Appendix for explanations of these ratings.

Qualified architects and interior designers use these acoustical rating values to determine which acoustical products will work best to satisfy the requirements of a certain installation. For detailed information about the acoustical performance of particular products, refer to CGC acoustical ceilings literature or contact the nearest sales representative for individual product data sheets. The acoustical performance values (CAC, NRC and AC) of CGC ceiling tile and panel products are independently verified under the Underwriters Laboratories Classification and Follow-Up Services Program.

Designing for Acoustical Performance

The key to controlling sound is to design ceiling solutions with products that meet specific sound control performance levels. For areas requiring excellent sound absorption, CGC has panels rated as "High NRC" with noise reduction ratings of .70 up to 1.00+. Open or perforated steel specialty products such as PARALINE, CELEBRATION, and CURVATURA can also obtain high sound absorption ratings by adding a fiberglass backer to the panels in the plenum area. Perforated PANZ, CELEBRATION and GEOMETRIX Metal Ceiling Panels achieve sound absorption through a unique integral backer called ACOUSTIBOND Backer. Using high NRC-rated ceiling systems in combination with wall and floor coverings, furniture, window treatments and other sound absorbing materials can help to create an ambient acoustic environment free from echoes and reverberations.

"High CAC" panels are also available with CAC values of up to 45. These do an excellent job of stopping sound transmission through the plenum. Sound attenuation is even better with the addition of acoustical barriers in the plenum between rooms, as well as acoustical sealant at room perimeters, to stop sound from moving around the ceiling plane.

Reducing speech intelligibility is typically the key objective in open plan facilities. This can require baffles and other sound attenuation measures in addition to noise reduction components. Additional measures can help to "mask" sound through the use of air diffusers, speakers, waterfalls or other methods of creating "white" noise.

Lighting and Light Reflectance

Lighting is one of the most important factors to consider in the design of interior spaces. To handle lighting situations correctly, the anticipated use or purpose of the space must be clearly understood first. Then, the illumination expectations for that space must be well defined. Of course, electrical service capacity should be sufficient to meet current needs as well as plans for future expansion.

Lighting should meet the esthetic and visual comfort criteria of the occupants and type of area. The amount of light, the types of sources and their placement affect the overall mood. Lighting can either be dramatic or subdued. It can be part of a general design or fulfill a specific task. Lighting designers and engineers can help determine what artificial light sources work best to complement ambient lighting and meet specific objectives.

Suspended acoustical ceilings play an important role in interior lighting. The suspension system is designed to support the mounting of lighting fixtures, and adds flexibility to the placement and relocation of those fixtures. Further, the panel selection can impact light reflectance and diffusion.

Many common lighting terms are defined in the Glossary in the Appendix.

Lighting Calculations

Interior general lighting calculations are generally used to determine how many luminaires are required to provide an average given illumination level in an interior space and how the luminaires should be arranged to provide uniform illumination throughout the space. A qualified lighting designer or engineer can be a valuable asset to your design team. Using the rated light output at the source and the source-to-surface distance, the engineer can calculate the number, type and placement of the luminaires.

$$\text{Illumination (footcandles)} = \frac{\text{lumens}}{\text{area (sq. ft.)}} \quad \text{or} \quad \text{fc} = \frac{\text{lumens}}{\text{sq. ft.}}$$

Determining the number and placement of luminaires is not as simple as the direct relationship above would suggest. It also is important to take into account absorption of light by wall, ceiling and floor surfaces, the interreflection of light, the efficiency or distribution of the luminaires, the shape of the room, etc. Those considerations result in a utilization factor that modifies the light-source-to-useful-light relationship.

$$\text{Illumination (footcandles)} = \frac{\text{lumens} \times \text{Coefficient of Utilization}}{\text{area (sq. ft.)}}$$

Light Reflectance

Light reflectance is an important factor in determining the amount of source illumination that will be required. Acoustical panels will have different degrees of whiteness, surface pattern and texture, all of which affects the amount of light they reflect.

CGC tests and measures panel reflectance in accordance with ASTM E-1477, Method for Luminous Reflectance Factor of Acoustical Materials by Use of Integrating-Sphere Reflectometers.

High light reflectance (High LR) ceiling panels enable architects and designers to use indirect light effectively. Pendulum, sconce and trim lighting directed at the ceiling produces a wash of light with three specific advantages:

1. Indirect lighting reduces glare against computer terminals, eyeglasses, and windows in an office space, creating a more enjoyable and productive work space.
2. Indirect lighting reduces up-front expenses as fewer fixtures are used in initial construction.
3. Indirect lighting also saves on energy costs over time.

Applications especially well suited for High LR panels include open office space, medical facilities, educational settings, libraries and computer rooms. Using light reflectance effectively can bring value to architects and owners by reducing glare, reducing initial construction costs and reducing energy costs.

Dramatic or Theatrical Lighting

Direct, indirect and spot lighting for dramatic effect can be facilitated with the use of curved or undulating ceiling treatments. CGC introduced COMPASSO, C2 (COMPASSO squared) and CURVATURA Ceiling Systems to provide just such an avenue for creative expression. These products open up creative design options well beyond the office environment.

Critical Lighting, or Cross-Lighting, as it is sometimes called, can be caused by perimeter fluorescent lights, or by the use of windows that rise to or beyond the ceiling plane. Many modern glazing systems are plane-polarized for occupant comfort, but this may produce very harsh illumination of the ceiling surface. Many ceiling products cannot withstand this harsh scrutiny. Recommended products to suit these conditions are MARS CLIMAPLUS, or OLYMPIA CLIMAPLUS. Products that have a fiberglass basemat, like PREMIER or HALCYON products, should be used with caution.

Retail space, entertainment complexes, restaurants and lobbies can be designed with very upbeat, upscale lighting. The use of both up-lighting and spot lighting with halogen light sources has become very popular in today's interior design. In these specialized spaces, it is even more important to acquire the services of a professional lighting designer.

Environmental Considerations

The typical environment for a suspended ceiling system is an enclosed and watertight building with all permanent heating and cooling systems in operation. All residual moisture from plaster, concrete or terrazzo has been dissipated. Temperatures remain in a range from 16-29°C (61-84° F), with relative humidity not exceeding 70%. Climatic conditions from outside these boundaries may have adverse effects on the panels and grid.

Typical Interior Environment: In some instances, ceiling systems can be specified to be used in some "non-standard" installations. CGC feels that the standard suspension systems and tiles should be installed in conditions that meet certain environmental requirements.

Higher Humidity Environments

When the ceiling system will be exposed to constant high temperatures and humidity, special panels and grid can be specified. CGC offers panels that will withstand high levels of humidity and temperature without sagging. These panels, categorized as CLIMAPLUS, are standard panels formulated with an added ingredient that remains stable in temperatures up to 40°C (104° F), and relative humidity up to 95%.

CLIMAPLUS Panels may be used in standard and typical environments as well. The technology allows for flexibility during and after construction, giving the installers the option to install before a building is entirely enclosed. CLIMAPLUS panels, when used with DOWN Grid Systems, carry a lifetime warranty.

In addition to CLIMAPLUS Panels, CGC offers a number of other special performance panels that can be used in situations such as swimming pools, kitchens, clean room areas, areas prone to abuse, and other non-standard installations.

Certain grids also are designed for unique situations. **DOWN AX** Suspension Grid is an aluminum grid that stands up especially well in areas such as over swimming pools and other areas of high moisture content. **AX** is rated as a light-duty system but its load capacity can be increased to reach intermediate levels by decreasing the hanger wire spacing to 915 mm (3') o.c.

Steel-bodied grid also is available with aluminum caps (**DOWN DXLA**), as well as environmental grid with hot-dipped-galvanized bodies and aluminum caps (**DOWN ZXA** and **ZXLA**) that are available in heavy and intermediate duty ratings. CGC also offers special performance panels that can be used in situations such as swimming pools, kitchens, clean room areas, areas requiring abuse resistant panels, and other non-standard installations.

For extreme environments, **DOWN DXSS** Stainless Steel Grid may be appropriate. A metallurgist should review its use in particularly corrosive environments.

Mould

Ceiling systems in Canada are not generally subject to mould growth, unless there is a structural defect in the building envelope, or a plumbing breach. CGC does, however, offer products (e.g. **ASTRO CLIMAPLUS**) with specific anti-microbial additives, with warranty protection to give building owners peace of mind. While there is no industry standard for measuring a ceiling product's resistance to mould growth, ASTM D3273 is one indicator, and is used by CGC to measure the efficacy of anti-microbial treatments.

Exterior Applications

Exterior applications are subject to environmental extremes. Suspended ceilings in exterior applications must be horizontal, covered, and protected. Typically these are exterior conditions such as parking decks, walkways, soffits or protected drive-thrus and building entrances.

These are applications that must address some new areas of concern when installing suspended ceilings. Outside forces such as wind, moisture and fluctuating temperatures must be dealt with. CGC offers a variety of products that can perform well in these environments, from standard grid and panel systems to specialty ceilings.

For a standard suspension system in an exterior application, CGC recommends using the **ZXA/ZXLA** environmental grid. The hot-dipped galvanized body, aluminum cap and stainless steel attachment clips make it a non-corrosive system. In conjunction with this grid, CGC provides **SHEETROCK** Brand Ceiling Lay-In Tile. These tiles consist of a **FIRECODE** gypsum core and white stipple vinyl facing. The tiles are durable, cleanable and stain resistant, making them an ideal choice for exterior applications.

The **ZXA** Grid/Gypsum Lay-In Tile system has been tested in actual wind tests to sustain winds of up to 193 km/h (120 mph). These tests were performed by an independent testing lab using compression posts at each hanger wire location (1220 mm (4') o.c.), and hold down clips (nails) on each panel. CGC recommends this type of installation in exterior conditions, subject to review by a structural engineer for each

project on an individual basis. To assure long-term integrity of the system and the structure, the plenum should be well ventilated.

Other specialty ceilings also perform well in protected exterior situations. CGC manufactures the PARALINE Linear Pan Ceiling System and the CELEBRATION 610 x 610 mm (2'x 2') Pan Ceiling System. Both may be used in sheltered exterior applications.

PARALINE Aluminum Pans used with the aluminum symmetrical carrier and compression posts have been tested in winds of up to 193 km/h (120 mph) (37 psf). CELEBRATION Aluminum Ceiling Panels have also been tested in winds up to 193 km/h (120 mph), snapped into a galvanized FINELINE Grid with SHEETROCK Brand Ceiling Lay-In Tiles, compression posts and hold-down clips. Both of these systems give architects the opportunity to specify a system that can be used as a continuous transition from indoors to outdoors. These systems also provide new and interesting alternatives for covered exterior projects.

Fire Safety

Combustibility Versus Fire-Rated Assemblies

Fire safety properties of suspended acoustical ceilings are widely misunderstood, largely because there are several terms with similar but different meanings. Flame Spread, Class A, non-combustible, fire resistance rating, and fire-rated assembly all mean different things. Sorting out the differences can help.

Non-combustible very simply means that the material will not burn. Class A designation on products means that the material can be ignited, but will not sustain a flame, and the fire will extinguish itself. Flame spread is a measure of the material's self-extinguishing characteristics. Both the characteristics of flame spread and smoke developed are measured in accordance with ASTM E-84, and the measurement will determine whether the material can be considered Class A. In Canada, surface burning characteristics (flame spread and smoke developed) are determined by tests in accordance with Canadian National Standard ULC S102-M. The "Class" system is not used in Canadian building codes. Rather, the codes regulate limits based on reported values from these tests.

None of these terms should be mistaken or substituted for fire-rated assemblies or fire resistance ratings.

Fire Resistance Rating and Fire-Rated Assemblies

Fifteen to twenty percent of all suspended ceilings are sold and installed as fire-rated designs. "Fire resistance rating" is the terminology that long has been used by Underwriters Laboratories Inc. and Underwriters Laboratories of Canada to reference the performance of various constructions. The ratings relate to fire-tests designed to measure the ability of a constructed assembly to resist the transfer flame, heat and hot gasses to the non-fire exposed side and maintain structural integrity for a measured time.

The very phrase "fire-resistance" causes one to think immediately of the characteristics discussed earlier, i.e. non-combustible. This causes an unfortunate misconception that, if Class A materials are used in a grid ceiling, it will stop a fire from spreading or that it is a "fire-rated" ceiling. That is not necessarily so.

Fire rated ceilings (or fire-rated assemblies) are tested and certified in their entirety. This includes everything included in the construction from the type of bar joists used to the type and size of acoustical panels. The entire design that was tested is identified in the *UL* or *ULC Fire Resistance Directory*.

Because the intense heat of a fire affects different materials in different ways, the materials need to be tested in context, or relative to one another. So a fire-rated ceiling assembly duplicates as closely as possible a small portion of the entire building including, but not limited to, concrete, bar joists, light fixtures, grid type, ceiling panel type, floor type, roof type, etc.

The *Underwriters Laboratories* and *ULC Fire Resistance Directories* list all of the types of constructions that have been tested in an actual fire environment. Although we are concerned primarily with ceilings in this chapter, the tests contained in the book also cover beams, columns, floors, roofs and wall constructions. It bears repeating, a fire rated assembly is the total construction as it was built and tested with all of the above. Any deviation from the construction tested leaves serious doubt as to the performance of the rest of the materials in the assembly.

Procedures for a Fire Test

The general method of testing a design for a fire-rated suspended ceiling is to actually build a room that will represent the typical construction and install a suspended ceiling in it. Depending on the type of construction, this room might include an actual concrete slab representing the floor above, bar joists if it is a roof construction, appropriate wall construction, fire-rated *Down Brand Grid System*, and *FIRECODE Ceiling Board*. If the ceiling has light fixtures and air diffusers, these are included too.

All of the UL and ULC fire tests are conducted in accordance with ASTM E-119, or CAN/ULC S101 M. The assembly passes when all requirements for conditions of acceptance are met such as temperature rise and structural integrity as mentioned earlier.

Every building material that is used in a fire-rated, tested design is listed in the test report in the UL and ULC Directories. Any deviation of the individual materials listed or in the manner it is installed, brings the performance of the final construction into question. The ultimate authority on any substitutions or changes rests with the local building official.

Types of Construction Tested

The primary types of fire tests for *Down Brand* fire-rated grid and *CGC* ceiling panels are based on the type of construction used for the structure. The UL and ULC test designation is keyed to those ceiling designs based on the prefix letter of the test:

A - Floor/Ceiling designs comprised of concrete cellular deck with cellular steel floor units and beam support.

D - Floor/Ceiling designs comprised of concrete with steel floor units and beam support.

G or I - Floor/Ceiling designs comprised of concrete and steel joists.

J or K - Floor/Ceiling designs comprised of precast and field-poured concrete.

L or M - Floor/Ceiling designs comprised of wood or combination wood and steel joists assemblies.

P or R - Roof/Ceiling designs.

These letter designations followed by three digit numbers are the designs called out in the *UL* and *ULC Directories* and written into the specifications. CGC has over 100 tested ceiling designs. Tests that incorporate DOWN Brand fire-rated grid and FIRECODE tile and panels are listed on the following pages. For specific information, refer to the latest *UL* or *ULC Fire Resistance Directories*.

Note: The following tests are correct as of the writing of this text. Both the tests and the construction specifications shown for them are subject to change from time to time. As a result, see the current CGC literature and the current *UL* and *ULC Fire Resistance Directories* to determine the status of a fire-rated design before specifying it.

All CGC's UL assemblies are listed in the UL Directory-Products Certified for Canada Volume 2. This certifies these assemblies are certified by UL to have been investigated under CAN/ULC S101 M for compliance to The National Building Code of Canada.

Fire-Rated Ceilings

| Construction Designs | UL Design No. | Assembly Rating | Approved Ceiling Tiles/Panels | Grid System | Maximum Fixture Size—% of Ceiling Area | Duct Area Per 100 Sq. Ft. of Ceiling Area | Assembly Construction Details |
|----------------------|---------------|-----------------|-------------------------------|-------------|--|---|-------------------------------|
|----------------------|---------------|-----------------|-------------------------------|-------------|--|---|-------------------------------|

A. Floor-Ceiling—Concrete with Cellular Steel Floor Units and Beam Support

| | | | | | | | |
|---------------------------------------|------|------------------------------------|--|--------------------------------------|---|-------------------------|--|
| Exposed Grid System and Lay-In Panels | A204 | 2 hr. R; 2 hr. UR; 2 hr. URB | GR-1; FR-81; FR-83; FR-4; M; FR-X1 | 610 x 1220 mm (2' x 4') By Others | Fluorescent type, 610 x 1220 mm (2' x 4')—24% | (113 in. ²) | 76 mm (3") concrete; Cellular deck; W8 x 28 beam |
|---------------------------------------|------|------------------------------------|--|--------------------------------------|---|-------------------------|--|

Additional UL designs are A203, A207, A003, A010

D. Floor-Ceiling—Concrete with Steel Floor Units and Beam Support

| | | | | | | | |
|---------------------------------------|------|------------------------------------|--|--|---|-------------------------|---|
| Exposed Grid System and Lay-In Panels | D201 | 2 hr. R; 2 hr. UR; 3 hr. URB | GR-1; FR-81; FR-83; FR-4; M; FR-X1 | 610 x 610 mm (2' x 2'); 610 x 1220 mm (2' x 4'); 508 x 1524 mm (20" x 60") DXL, ZXLA, DXLZ, SDXL, DXLA, DXLZA, SDXLA | Fluorescent type, 610 x 1220 mm (2' x 4')—24%, 508 x 1220/1524 mm (20" x 48"/60") | (576 in. ²) | 38 mm (1-1/2") concrete; Cellular deck; W8 x 31 beam |
|---------------------------------------|------|------------------------------------|--|--|---|-------------------------|---|

Additional UL designs are D209, D219

G. Floor-Ceiling—Concrete and Steel Joist

| | | | | | | | |
|---------------------------------------|------|------------------------------------|--|--|--|--|--|
| Exposed Grid System and Lay-In Panels | G204 | 2 hr. R; 2 hr. UR; 2 hr. URB | GR-1; FR-81; FR-83; FR-4; M; FR-X1 | 610 x 610 mm (24" x 24") to 762 x 1524 mm (30" x 60") DXL, DXLA, DXLZ, SDXL, DXLZA, SDXLA | Fluorescent type, 610 x 610 mm (24" x 24"); 610 x 1220 mm (24" x 48"); 610 x 1524 mm (24" x 60"); 24%; 610 x 610 mm (2' x 2') HD; Incandescent type, 165 mm (6-1/2") diam. | (113 in. ²) (576 in. ²) | 64 mm (2-1/2") concrete; Metal lath or deck; 254 mm (10") bar joists 762 mm (30") o.c. W6 x 12 Beam |
| | G262 | 1-1/2 hr. R; 1-1/2 hr. UR | GR-1; FR-83; FR-X1 | 610 x 610 mm (2' x 2'); SQ, ILT edge DXLT, DXLTA | Fluorescent type, 610 x 1220 mm (2' x 4')—24% | (113 in. ²) | 64 mm (2-1/2") concrete; Steel deck; 203 mm (8") bar joists 610 mm (24") o.c. |
| | G264 | 1-1/2 hr. R; 1-1/2 hr. UR | GR-1; FR-X1; FR-83 | 610 x 610 mm (2' x 2'); FL edge DXLF | Fluorescent type, 610 x 1220 mm (2' x 4')—24% Incandescent type, 165 mm (6-1/2") diam. | (113 in. ²) | 64 mm (2-1/2") concrete; Steel deck; 89 bar joists 610 mm (24") o.c. |

Additional UL designs are G203, G211, G213, G202, G215, G222, G227, G228, G230, G231, G265, G259, G201, G017, G002, G007, G008, G011, G018, G037, G040, G020. ULC designs are G018, G020, I221, I222, I223, I519, I520

J or K. Floor-Ceiling—Precast and Field Poured Concrete

| | | | | | | | |
|---------------------------------------|------|----------------------|--|--|--|-------------------------|--|
| Exposed Grid System and Lay-In Panels | J201 | 2 hr. R; 2 hr. UR | GR-1; FR-81; FR-83; FR-4; M; FR-X1 | 610 x 610 mm (2' x 2'); 610 x 1220 mm (2' x 4'); 508 x 1524 mm (20" x 60") DXL, DXLT, DXLZ, SDXL, DXLTZ | Fluorescent type, 610 x 1220 mm (2' x 4')—24% Incandescent type, 165 mm (6-1/2") diam. | (576 in. ²) | 64 mm (2-1/2") concrete floor with 152 mm (6") concrete stems |
|---------------------------------------|------|----------------------|--|--|--|-------------------------|--|

Additional UL designs are J202

L. Floor-Ceiling—Wood or Combination Wood and Steel Joist Assemblies

| | | | | | | | |
|---------------------------------------|------|---|--|--|--|-------------------------|--|
| Exposed Grid System and Lay-In Panels | L206 | 1 hr. UR; Finish Rating: 17 min. | 19 mm (3/4") GR-1; 19 mm (3/4") FR-83; FR-X1 | 610 x 610 mm (2' x 2'); 610 x 1220 mm (2' x 4') DXL, DXLA, DXLZ, SDXL, DXLZA, SDXLA | Fluorescent type, 610 x 1220 mm (2' x 4')—8% Incandescent type, 165 mm (6-1/2") diam. —0.5% | (110 in. ²) | Wood floor; 51 x 254 mm (2" x 10") wood joists 406 mm (16") o.c. |
|---------------------------------------|------|---|--|--|--|-------------------------|--|

Additional UL designs are L211, L202, L206, L212, L003, L006. ULC designs are L003

Fire-Rated Ceilings (continued)

| Construction Designs | UL Design No. | Assembly Rating | Approved Ceiling Tiles/Panels | Grid System | Maximum Fixture Size—% of Ceiling Area | Duct Area Per 100 Sq. Ft. of Ceiling Area | Assembly Construction Details |
|---------------------------------------|---------------|--|---|--|--|---|--|
| P. Roof Ceiling | | | | | | | |
| Exposed Grid System and Lay-In Panels | P237 | 2 hr. R; 2 hr. UR; 2 hr. URB | FR-4; FR-83; GR-1; FR-X1 | 610 x 1220 mm (2' x 4') DW (for drywall), DXL, DXLA, ZXLA, DXLZ, SDXL, DXLZA, SDXLZ (for panels) | Florescent type, 305 x 1220 mm (1' x 4')—16%; 610 x 610 mm (2' x 2')—20%; 610 x 1220 mm (2' x 4')—24%; Incandescent type, 165 mm (6-1/2") diam. | (144 in. ²) Linear air returns | Unlimited insulation; Steel deck; 203 mm (8") bar joists 1829 mm (72") o.c.; 12.7 mm (1/2") Firecode C Gypsum Panel Ceiling w/152 mm (w/6") fiber glass insulation |
| | P230 | 1-1/2 hr. R; 1-1/2 hr. UR; 1-1/2 hr. URB | GR-1; FR-4; FR-83; FR-X1 | 610 x 610 mm (2' x 2'); 610 x 1220 mm (2' x 4'); 508 x 1524 mm (20" x 60") DXL, DXLA, DXLP, ZXLA, DXLZ, SDXL, DXLZA, SDXLA | Florescent type, 610 x 1220 mm (2' x 4')—24%; Incandescent type, 165 mm (6-1/2") diam.; 610 x 610 mm (2' x 2') HD | (255 in. ²) (576 in. ²) for 1-hr. | Unlimited insulation; Gypsum panels or Durock on steel deck; 254 mm (10") bar joists 1829 mm (72") o.c.; 152 x 305 mm (6" x 12") beam |
| | P254 | 1 hr. R; 3/4 hr. UR; 3/4 hr. URB | 19 mm (3/4") GR-1; 19 mm (3/4") FR-81; 19 mm (3/4") FR-83 | 610 x 610 mm (2' x 2'); FL edge DXLF | Florescent type, 610 x 610 mm (2' x 2') or 610 x 1220 mm (2' x 4')—24%; Incandescent type, 165 mm (6-1/2") diam. | (113 in. ²) | Unlimited insulation; Gypsum wallboard; Steel roof deck, 254 mm (10") bar joists 1220 x 1829 mm (48" to 72") o.c. |
| | P268 | 1-1/2 hr. R; 1-1/2 hr. UR; 1-1/2 hr. URB | 19 mm (3/4") GR-1; 19 mm (3/4") FR-81; 19 mm (3/4") FR-83; FR-X1 | 610 x 610 mm (2' x 2'); DXL, DXLA, ZXLA, DXLZ, SDXL, DXLZA, SDXLA | Florescent type, 610 x 1220 mm (2' x 4')—24% | (576 in. ²) | Metal roof deck panels; glass fiber insulation; steel roof purfins 1524 mm (60") o.c.; ceiling panels backloaded w/152 mm (w/6") fiber glass |

Additional UL designs are P213, P241, P201, P202, P214, P267, P235, P238, P245, P246, P255, P257, P269, P203. ULC designs are R220, R221, R223

Product Codes for Fire Tests

FIRECODE ACCUSTONE TILE

G=FROST, GLACIER, "F"-FISSURED ceiling tile

W=FROST, GLACIER, "F"-FISSURED ceiling tile

AP=FROST, GLACIER, "F"-FISSURED ceiling tile

FIRECODE ACCUSTONE PANELS

AP=SANDRIFT, FROST, GLACIER, "F"-FISSURED ceiling panels

AP-1=SANDRIFT, FROST, GLACIER, "F"-FISSURED ceiling panels

FIRECODE Special Function Gypsum Lay-In Panels *CLIMAPLUS*

FC-CB=Gypsum Lay-In ceiling panels

FIRECODE AURATONE, Special Function ORION *CLIMAPLUS*, MILLENNIA *CLIMAPLUS* and ECLIPSE *CLIMAPLUS* Panels

GR-1=Illusion, Aspen, Fissured ceiling panels

FR-X1=ORION *CLIMAPLUS*, ECLIPSE *CLIMAPLUS*, MILLENNIA *CLIMAPLUS* (clay back) ceiling panels

FR-83=RADAR, Fissured, Pebbled, ROCK FACE *CLIMAPLUS*, CLEAN ROOM *CLIMAPLUS* ceiling panels

FR-4=RADAR CERAMIC *CLIMAPLUS* ceiling panels

General Notes for DXL/DXLA fire-rated systems

- Hanger wire should be located between the main tee splice and the expansion relief notch and a maximum 1220 mm (48") o.c., or per the requirements of the specific UL design.
- All 1524 mm (60") cross tees are to have hanger wires at their midpoint.
- Assemblies are tested with the method and criteria established in Standard UL 263, also known as A2.1, ASTM E-119 and NFPA 251.

4. Hold-down clips are required when the fire-rated board used weighs less than 4.8 kg/m² (1.0 lb./ft.²).
5. % Fixtures column indicates 610 x 1220 mm (24" x 48") fixture only, unless noted. Check for suspension requirements.
6. Some designs pertain for DXL only. Contact *UL Fire Resistance Directory* and revisions to confirm all information listed in these tables.
7. DXLA and ZXLA are also listed by UL.
8. DXL has been used in many other industry fire tests and listed in reports such as the National Evaluation Reports, for example, NER-148 and NER-399 (wood truss constructions).
9. Check UL Designs for deck options.

Additional DXL fire-rated assemblies

3 hr.: G-229

2 hr.: A-202, D-208, G-208, G-209, G-218, G-229, G-236, G-243, G-250, G-258 [Concealed systems D-010, G-022]

1-1/2 hr.: A-210, G-229, G-241, G-243, L-208, P-207, P-225, P-227, P-231, P-251

1 hr.: G-241, L-206, L-209, L-210, L-212, P-206, P-210, P-225, P-227, P-244, P-245, P-257, P- 509, P-513

3/4 hr.: P-204

Seismic Requirements for Suspended Acoustical Ceilings

Although most people are familiar with earthquakes on the west coast, every area of the world experiences seismic activity of some degree. Because of this, some areas require buildings to have extra structural support to resist these imposed seismic forces. The challenge to the architect is to determine if the building and/or installation needs extra lateral (horizontal) bracing, and if so, how much. The first step in determining the seismic bracing requirements for a building is to determine what the building code requires in the area where the building will be located.

Resisting Seismic Disturbance

Areas subject to seismic disturbance may have added requirements for suspended ceilings. Extra bracing for ceilings in these areas is required primarily to prevent injury and keep the ceiling moving along with the building during seismic activity.

DOWN Suspension Systems are continuously tested for minimum tension and compression strength at all connections (based on ASTM E580 requirements). In addition, taut, splayed hanger wires that resist horizontal movement (next page, top), and compression posts to resist vertical movement (next page, bottom) are common installation practices in seismic construction and are covered in standard ASTM E-580.

The building code can be used to determine the need and amount of bracing, but often this standard is used as default.

Local officials have the final say as to what seismic bracing requirements and construction details must be used. Each job may have unique seismic requirements as well as varying factors depending on location, type of building, and construction details. It is advised that a local professional structural engineer review each installation to ensure adequate planning for the necessary seismic bracing.

Splayed tie wires restrict lateral movement.

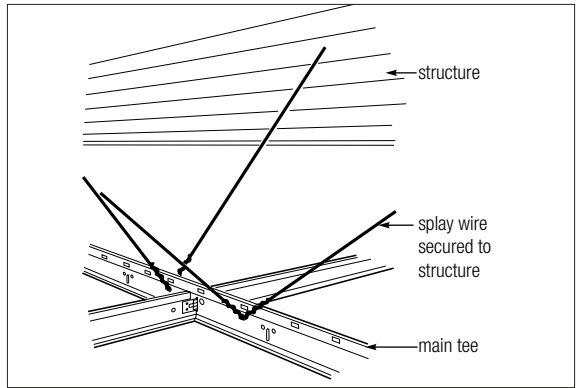

Compression post restricts vertical movement.

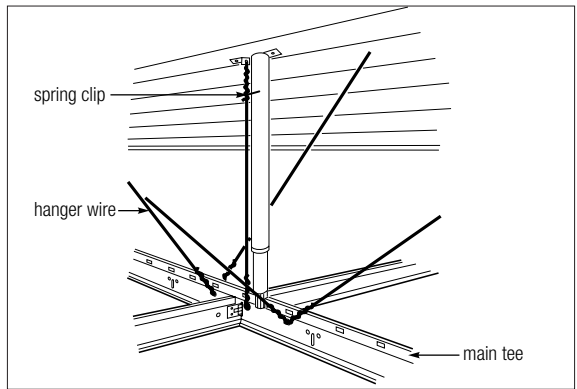

Heating, Ventilation and Air Conditioning

9

Air distribution is an integral part of many suspended ceiling systems. The delivery of heated and air conditioned air to the areas below the ceiling is a major factor in the design of any ceiling system. The architect or designer must consider the amount of air flow and the distribution of the air from the HVAC equipment which is required to service a particular area. Typically, the air is delivered through diffusers in the ceiling system and is controlled by the amount of pressure produced by the HVAC equipment.

The movement and discharge of air into a conditioned space has a direct effect on the quality of the acoustical environment within the space. The acceptability of the sound caused by air movement depends on its loudness, its sound spectrum and its relationship to other sounds existing within the space.

Loudness of the air supply being delivered through an air diffuser is measured in decibels and the air diffusers are rated based on noise criteria (NC) for a given air flow in litres per second (L/s) or cubic feet per minute (CFM). In most cases, the loudness of the sound caused by air movement must be kept low so as to not interfere with necessary communication sounds. Sometimes, however, a relatively higher level can be used to mask or cover other undesirable sounds and/or to provide for conversational privacy.

The acoustical design should be based on a thorough analysis of the practical requirements of the of the conditioned space. This, generally, will be a balance between the sound caused by the air movement and other existing sounds, such as necessary communication sounds, sounds penetrating from the building exterior, and sounds intruding from adjacent spaces. The typical benchmark for noise produced by an air diffuser is a maximum of 35 NC in an office environment.

CGC offers standard 610 x 610 mm (2' x 2') air diffusers for 14 mm (9/16") grid ceilings. The air diffuser interface with the ceiling surface must maintain visual appeal and provide a clean, discreet slot for air flow. These diffuser units offer four-way air flow capability for optimum directional control and are available in one, two, three or four-slot versions for maximum flexibility in air delivery requirements.

The chart below lists design ranges for noise criteria (NC) for various indoor spaces:

Sound Control Guidelines for Air Handling Systems

| Type of Area | | Noise Criteria Range |
|---------------------------|--|----------------------|
| Residences | Apartment houses, 2 and 3 family units | 30-40 |
| Hotels | Ballrooms, Banquet rooms | 30-40 |
| | Halls and corridors, Lobbies | 35-45 |
| | Garages | 40-50 |
| Hospitals and Clinics | Operating rooms, Wards | 30-40 |
| | Laboratories, Halls and corridors, Lobbies and waiting rooms | 35-45 |
| Offices | Conference rooms | 25-35 |
| | Reception rooms | 30-40 |
| | General open office, Drafting rooms | 35-50 |
| | Halls and corridors | 35-55 |
| Auditoriums | Multi purpose halls | 25-30 |
| | Semi-outdoor amphitheaters, Lecture halls, Planetarium | 30-35 |
| | Lobbies | 35-45 |
| Schools | Libraries | 30-40 |
| | Classrooms | 30-40 |
| | Laboratories | 35-45 |
| | Recreation halls | 35-50 |
| | Corridors and halls | 35-50 |
| Public Buildings | Public libraries, Museums, Court rooms | 30-40 |
| | Post offices, General banking areas, Lobbies | 35-45 |
| | Washrooms and toilets | 40-50 |
| Restaurants, Cafeterias | Restaurants | 35-45 |
| | Cafeterias | 40-50 |
| Stores, Retail | Clothing stores | 35-45 |
| | Department stores, Small retail stores | 40-50 |
| | Supermarkets | 40-50 |
| Sports Activities, Indoor | Coliseums | 30-40 |
| | Bowling alleys, Gymnasiums | 35-45 |
| | Swimming pools | 40-55 |
| Transportation | Ticket sales office | 30-40 |
| | Lounges and waiting rooms | 35-50 |

Source: American Society of Heating, Refrigerating and Air-Conditioning Engineers, Inc.
 Noise Criteria (NC) is important to the design of the HVAC system and selection of the proper air diffuser.

Down Air Diffuser

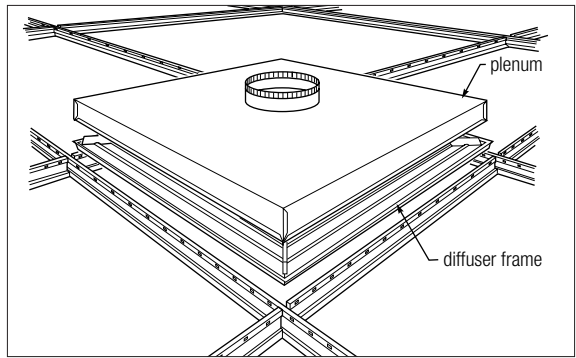

Installation of Suspended Acoustical Ceilings

The appearance of a suspended acoustical ceiling is dependent both on the materials used and on the quality of the installation. CGC manufactures components to meet ASTM C635, assuring that the material, structural and quality standards are as prescribed. Installation must meet ASTM 636, assuring proper level and secure attachment as prescribed.

Measuring and planning are key first steps in the installation process. Measurement and placement of the tees will be on center (o.c.), meaning from the center of one to the center of the next. Several components are involved:

Wall Angle is L, W or C-shaped metal strips that provide a continuous finished edge around the perimeter of the ceiling, where it meets the wall.

Main Tees are the metal framing members. They run the full length or width of the room (preferably perpendicular to joists) between the wall angles, and perform as the primary support for the ceiling's weight. They are hung by hanger wire from joists or other supports above.

Cross Tees snap into main tees at right angles, and serve as secondary support members for individual ceiling panels. They generally come in two lengths: 1220 mm (4'), used for both 610 x 1220 mm (2' x 4') and 610 x 610 mm (2' x 2') grid patterns; and 610 mm (2') for 610 x 610 mm (2' x 2') only. Some suspension systems offer 915 mm (3'), 1524 mm (5') and 2438 mm (8') cross tees for different module applications.

Ceiling Panels lay in the open areas once the grid is assembled. Panels are supported by the grid along all four edges.

Hanger Wire typically is 2.7 mm (12 gauge), to support the main runners, every 1220 mm (4') o.c., along the entire length of each main runner.

Planning

Start with a drawing of the room that shows all walls, including bays, alcoves beams and stairwells. Note which direction the joists are running, then determine the center line of the room's long direction. (If the center line is perpendicular to the joists, installation of the tees will be easier.)

Locate the main tees by starting at the center line and marking 1220 mm (4') intervals to each side wall. If more than 610 mm (2') remain between the last mark and the side wall, place the main tees at these locations. If less than 610 mm (2') remain, locate the first two main tees 610 mm (2') either side of the center line and place all other main tees at 1220 mm (4') intervals. This procedure assures symmetrical border panels of the largest possible cut size.

Locate cross tees at 610 mm (2') intervals perpendicular to the main tees. Follow the same procedure as above to be sure border panels are the same size. For a 610 x 610 mm (2' x 2') grid pattern, indicate additional 610 mm (2') cross tees by bisecting each 610 x 1220 mm (2' x 4') module.

Tools

See Chapter 14, Tools & Equipment, for information about applicable tools.

Step-By-Step Installation

Good construction conditions are very important to the success of a finished ceiling. It is recommended that the temperature and humidity range be 16-29°C (60-85° F) and 70% relative humidity. Store materials in a protected area.

1. Choose the desired ceiling height, maintaining at least 76 mm (3") clearance below the lowest duct, pipe or beam. Measure and mark the walls at corners 22 mm (7/8") above desired ceiling height.
2. Snap a chalk line and test for level. Measuring down from joists or up from floor is not recommended, since either might not be level.
3. Install wall angle with top edge of angle at the chalk line, spacing nails 610 mm (2') o.c. or closer.
4. Cut inside angles at 90° and miter outside angles at 45°, fitting them snugly together.
5. Stretch a string taught along positions main tees will occupy to assure level. Inserting a nail between the wall and the wall angle at marked locations serves as a good anchor for this purpose.
6. Stretch another string across the room where first row of cross tees will be located. This identifies where the first prepunched slots need to fall. Check to be sure the cross tee string is at 90° to the main tee string via the 3-4-5 method.
7. Install lag screws or screw eyes tightly into joists or suitable substrate at 4' intervals, attach hanger wire (1.2 mm (18-ga.) for residential, 2.8 mm (12-ga.) for commercial). The wires should extend 150 mm (6") below the string line.
8. Bend wires 19 mm (3/4") above string line with a pliers.
9. In each row, trim the main tee so that the cross-tee slot will line up with the cross-tee string.
10. Mount main tees, resting the cut end of the main tee on the wall angle and attaching wires by pulling them through the round hanger holes in the main tees. After checking the string line to be sure the tee is level, bend the wire up and around, twisting the wire tightly at least 3-1/2 turns to secure it. If the nearest hanger hole is not directly below the screw eye, adjust hanger length accordingly or punch new holes at those locations.

11. Install cross tees, assuring that they are adequately connected to main tees (they “click” in place when properly seated). Where two cross tees intersect in the same slot, insert second cross-tee end to the left of the first. Where a cross-tee is installed without an opposing cross-tee, a nail must be slipped into the opening of the cross-tee clip to maintain the pull-out value for the cross-tee. This is known as an Ashlar Condition.
12. Lay in panels, beginning at one corner and completing row by row. Tilt each panel up through the opening and lower it to rest squarely on all four tees.

Other tips Install light fixtures and wiring before installing ceiling. Cut tees with aviation snips, first the stem and then the flanges. Cut panels with utility knife and straight edge, cutting the face first. Cut panels should be 19 mm (3/4”) larger than the opening. To install panels around obstructions, draw their exact locations on the panels and cut out; cut panel from hole to side to enable fitting. To trim for Shadowline edge, use a utility knife to cut panel, first at face, then from edge, to same depth as Shadowline. If windows, stairwells, etc., extend above ceiling plane, build suitable valances and attach wall angle.

