

# ICC-ES Evaluation Report

**ESR-1846**

Reissued October 2025

This report also contains:

- [CA Supplement](#)

Subject to renewal October 2026

ICC-ES Evaluation Reports are not to be construed as representing aesthetics or any other attributes not specifically addressed, nor are they to be construed as an endorsement of the subject of the report or a recommendation for its use. There is no warranty by ICC Evaluation Service, LLC, express or implied, as to any finding or other matter in this report, or as to any product covered by the report.

Copyright © 2025 ICC Evaluation Service, LLC. All rights reserved.

<p><b>DIVISION: 03 00 00 — CONCRETE</b></p> <p><b>Section: 03 54 00 — Cementitious Underlayment</b></p>	<p><b>REPORT HOLDER:</b></p> <p><b>USG CORPORATION</b></p>	<p><b>EVALUATION SUBJECT:</b></p> <p><b>USG LEVELROCK BRAND 2500,</b></p> <p><b>USG LEVELROCK BRAND 2500 FR,</b></p> <p><b>USG LEVELROCK BRAND 2500 GREEN,</b></p> <p><b>USG LEVELROCK BRAND 2500 GREEN FR,</b></p> <p><b>USG LEVELROCK BRAND 2500 LFD,</b></p> <p><b>USG LEVELROCK BRAND 3500,</b></p> <p><b>USG LEVELROCK BRAND 3500 FR,</b></p> <p><b>USG LEVELROCK BRAND 3500 GREEN,</b></p> <p><b>USG LEVELROCK BRAND 3500 GREEN FR,</b></p> <p><b>USG LEVELROCK BRAND 4500,</b></p> <p><b>USG LEVELROCK BRAND 4500 FR,</b></p> <p><b>USG LEVELROCK BRAND CSD EARLY EXPOSURE.</b></p>	
---	--	--	---

## 1.0 EVALUATION SCOPE

**Compliance with the following codes:**

- 2024, 2021, 2018, 2015 and 2012 [International Building Code® \(IBC\)](#)
- 2024, 2021, 2018, 2015 and 2012 [International Residential Code® \(IRC\)](#)

**Properties evaluated:**

- Fire-resistance-rated construction
- Sound transmission
- Compressive Strength

## 2.0 USES

USG Levelrock Brand gypsum concrete products are used as floor underlayments. The gypsum concrete underlayments may be used in fire-resistance-rated floor/ceiling assemblies in accordance with IBC Sections 703 and 711 and IRC Section R302.3 when installed in accordance with Sections 4.0 and 4.1 and [Figures 1](#) through [5](#). The gypsum concrete underlayments are used in floor/ceiling assemblies to provide both air-borne sound and structure-borne sound classes when installed as described [Tables 3](#) through [8](#) in accordance with 2024, 2021 and 2018 IBC Section 1206 (2015 and 2012 IBC Section 1207) and 2024 IRC Appendix BG [2021 IRC Appendix AK (2018, 2015 and 2012 IRC Appendix K)].

## 3.0 DESCRIPTION

### 3.1 Gypsum Concrete:

The USG Levelrock Brand 2500, USG Levelrock Brand 2500 FR, USG Levelrock Brand 2500 Green FR, USG Levelrock Brand 2500 LFD, USG Levelrock Brand 3500, USG Levelrock Brand 3500 FR, USG Levelrock Brand 3500 Green FR, USG Levelrock Brand 4500 FR, USG Levelrock Brand 4500 FR, and USG Levelrock Brand CSD Early Exposure are dry mixes consisting of gypsum and Portland cement provided in bags or containers of various sizes. The shelf-life of the dry mixes is specified in the report holder's published installation instructions.

Each of the gypsum concrete products, when mixed in accordance with the manufacturer's specifications at various densities between 110 pcf and 130 pcf (1,760 and 2,080 kg/m<sup>3</sup>), have the following minimum compressive strengths when based on testing in accordance with ASTM C472:

- USG Levelrock Brand 2500, USG Levelrock Brand 2500 FR, USG Levelrock Brand 2500 Green, USG Levelrock Brand 2500 Green FR, USG Levelrock Brand 2500 LFD: 2,000 psi (13.8 MPa)
- USG Levelrock Brand 3500, USG Levelrock Brand 3500 FR, USG Levelrock Brand 3500 Green, USG Levelrock Brand 3500 Green FR: 3,000 psi (20.7 MPa)
- USG Levelrock Brand 4500, USG Levelrock Brand 4500 FR, USG Levelrock Brand 4500 Green FR: 4,000 psi (27.6 MPa)
- USG Levelrock Brand CSD Early Exposure: 3,500 psi (24.1 MPa)

USG Levelrock Brand gypsum concrete products are used with various USG Levelrock Brand sound mats and sound reduction board (see [Table 1](#)) and other products as components of floor/ceiling assemblies.

## 4.0 DESIGN AND INSTALLATION

USG Levelrock Brand gypsum concrete products are mixed with sand and water on the jobsite and pumped into place by USG approved installers. Mixing and installation must be in accordance with the report holder's published installation instructions.

### 4.1 Fire-resistance-rated Floor/Ceiling Assembly:

The 1-hour and 2-hour fire-resistance-rated floor/ceiling assemblies shown in [Figures 1](#) through [5](#) are based on a specific UL design. When using one of these assemblies, all details must be in accordance with the specifications contained in the UL *BXUV GuideInfo*.

### 4.2 Sound Transmission Rated Floor/Ceiling Assemblies:

When installed as described in [Tables 3](#) through [8](#), and corresponding [Figures 6](#) through [11](#), the assemblies provide a minimum Sound Transmission Class (STC) of 50 under 2024, 2021 and 2018 IBC Section 1206.2 (2015 and 2012 IBC Section 1207.2), and/or a minimum Impact Insulation Class (IIC) of 50 under 2024, 2021 and 2018 IBC Section 1206.3 (2015 and 2012 IBC Section 1207.3) or a minimum Sound Transmission Class (STC) of 45 under 2024 IRC Section BG102 (2021, 2018, 2015 and 2012 IRC Section AK102) and/or a minimum Impact Insulation (IIC) of 45 under 2024 Section BG103 (2021, 2018, 2015 and 2012 IRC Section AK103).

## 5.0 CONDITIONS OF USE:

The products described in this report comply with, or are suitable alternatives to what is specified in, those codes listed in Section 1.0 of this report, subject to the following conditions:

- 5.1 Installation must comply with this report, the report holder's published instructions and the applicable code. In the event of a conflict between the report holder's published installation instructions and this report, this report governs.
- 5.2 Application must be by installers approved by USG Corporation.
- 5.3 Use of the products as components of fire-classified roof coverings or roof/ceiling assemblies is outside the scope of this report.

## 6.0 EVIDENCE SUBMITTED

- 6.1 Reports of sound transmission testing in accordance with ASTM E492 and ASTM E90 and engineering analysis.
- 6.2 Engineering analysis based on report of fire resistance testing and physical properties of the gypsum concrete underlayments.
- 6.3 Reports of density and compressive strength testing.
- 6.4 Product literature and quality documentation.

## 7.0 IDENTIFICATION

- 7.1 The ICC-ES mark of conformity, electronic labeling, or the evaluation report number (ICC-ES ESR-1846) along with the name, registered trademark, or registered logo of the report holder (USG Corporation) must be included in the product label.
- 7.2 In addition, the bags of gypsum concrete dry mix are identified with the product name, the manufacturing plant code, the date of manufacture, and the ICC-ES mark of conformity. The evaluation report number (ICC-ES ESR-1846) may be used in lieu of the mark of conformity.
- 7.3 The report holder's contact information is the following:

**USG CORPORATION**  
**550 WEST ADAMS STREET**  
**CHICAGO, ILLINOIS 60661**  
**(800) 874-4968**  
[www.usg.com](http://www.usg.com)

TABLE 1—MINIMUM UNDERLAYMENT DEPTH OVER SOUND MAT

SOUND MAT OR BOARD MATERIALS	NOMINAL THICKNESS (inch)
SAM-N12™	1/8
SAM-N12™ Ultra	3/16
SAM-N25™	1/4
SAM-N25™ Ultra	5/16
SAM-N40™	2/5
SAM-N40™ Ultra	7/16
SAM-N75™	3/4
SAM-N75™ Ultra	11/16
SRM-25™	1/4
SAM-CSD™	3/8

For SI: 1 inch = 25.4 mm.

TABLE 2—ABBREVIATIONS FOR GYPSUM CONCRETE PRODUCTS USED IN FIRE-RESISTANCE RATED ASSEMBLY DESCRIPTIONS

ABBREVIATION	PRODUCT	ABBREVIATION	FLOOR TOPPING TYPE
LRK	Levelrock 2500	HSLRK	Levelrock 4500
	Levelrock 2500 FR		Levelrock 4500 FR
	Levelrock 2500 Green	CSD	Levelrock CSD Early Exposure
	Levelrock 2500 Green FR		
	Levelrock 2500 LFD		
	Levelrock 3500		
	Levelrock 3500 FR		
	Levelrock 3500 Green		
	Levelrock 3500 Green FR		

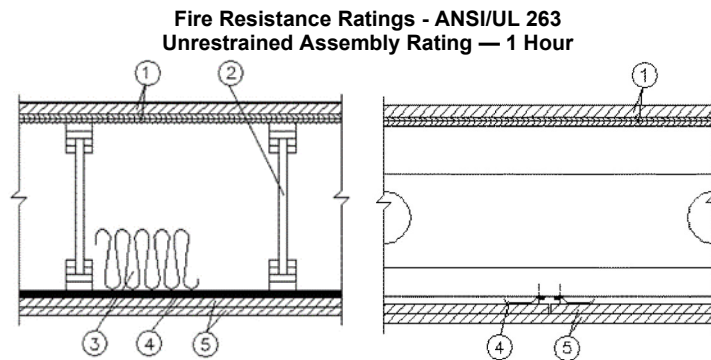

Where noted with an “\*\*” in the description below, the product must bear the UL Classification Mark.

FIGURE 1—1-HOUR FLOOR/CEILING ASSEMBLY CONSTRUCTED WITH WOOD I-JOISTS

For SI Units: 1 inch = 25.4 mm, 1 foot = 0.3048 m, 1 pound = 4.45 N

**1. Flooring System** — The flooring system shall consist of the following:

**Subflooring** — Nominal 19/32 inches thick wood structural panels installed perpendicular to the joists with end joints staggered. Plywood or panels secured to joists with construction adhesive and No.6d ringed shank nails, spaced 12 inches on center along each joist. Staples having equal or greater withdrawal and lateral resistance strength may be substituted for the 6d nails.

**Vapor Barrier** — (Optional) - Nominal 0.010-inch-thick commercial asphalt saturated felt.

**Finish Flooring\*** — Floor Topping Mixture — Minimum 3/4-inch thickness of floor topping mixture having a minimum compressive strength of 1800 psi. Refer to manufacturer’s instructions accompanying the material for specific mix design.

UNITED STATES GYPSUM CO — Types LRK, HSLRK, CSD  
USG MEXICO S A DE C V — Types LRK, HSLRK, CSD

**Floor Mat Materials\*** — (Optional) — Floor mat material loose laid over the subfloor. Refer to manufacturer’s instructions regarding the minimum thickness of floor topping over each floor mat material.

UNITED STATES GYPSUM CO — Types SAM, LEVELROCK® Brand Sound Reduction Board, LEVELROCK® Brand Floor Underlayment SRM-25

**2. Structural Wood Members\*** — Minimum 9 1/2 inches deep "I" shaped wood joists spaced at a maximum of 19.2 inches on center. Joists shall conform to ICC-ES [ESR-1153](#). Joist top and bottom chords minimum 1 3/8 inches deep by 2.3 inches wide and constructed of either Microllam laminated veneer lumber (LVL) or TimberStrand laminated strand lumber (LSL). Webs constructed of minimum 3/8-inch-thick Performance Plus OSB, PS2, Exposure 1. Installation shall be in accordance with manufacturers published literature. Spacing may be increased to 24 inches on center when **Batts and Blankets\*** (Item 3B) is used.

**3. Insulation\*** — **Batts and Blankets** — (Optional) — Glass fiber insulation, secured to the subflooring with staples, or to the wood joists with 0.090-inch diameter galvanized steel wires, or draped over the resilient channel/gypsum panel (or Steel Framing Members/gypsum panel) ceiling membrane. Any thickness of glass fiber insulation bearing the UL Classification Marking as to Surface Burning Characteristics and/or Fire Resistance.

**3A. Insulation\*** — **Loose Fill Material** — As an alternate to Item 3 — Any thickness of loose fill material bearing the UL Classification Marking for Surface Burning Characteristics, applied within the concealed space, over the resilient or furring channel/gypsum panel or Steel Framing Members/gypsum panel ceiling membrane.

**3B. Insulation\*** — **Batts and Blankets** — (For Use When **Structural Wood Members\*** are spaced 24 inches on center) — minimum 1-inch-thick glass fiber insulation bearing the UL Classification Marking as to Surface Burning Characteristics and/or Fire Resistance draped over the resilient channel/gypsum panel (or Steel Framing Members/gypsum panel) ceiling membrane.

**4. Furring Channels** — Resilient channels formed of 25 MSG thick galvanized steel. Installed perpendicular to the joists, spaced a max of 24 inches on center when no insulation is fitted in the concealed space, or 16 inches on center when insulation is fitted in the concealed space. Two courses of resilient channel positioned 6 inches on center at gypsum panel butt-joints (3 inches from each end of wallboard). Channels oriented opposite at gypsum panel butt-joints. Channel splices overlapped 4 inches beneath wood trusses. Channels secured to each truss with 1<sup>1</sup>/<sub>4</sub>-inch-long Type S screws.

**4A. Alternate Steel Framing Members** — (Not Shown) — As an alternate to Item 4, main runners, cross tees, cross channels and wall angle as listed below:

a. **Main Runners** — Nominal 10 or 12 feet long, 1<sup>5</sup>/<sub>16</sub> inch or 1<sup>1</sup>/<sub>2</sub>-inch-wide face, spaced 4 feet on center. Main runners suspended by minimum 12 SWG galvanized steel hanger wires spaced 48 inches on center. Hanger wires to be located adjacent to main runner/cross tee intersections. Hanger wires wrapped and twist-tied on 16d nails driven into side of joists at least 5 inches above the bottom face.

b. **Cross Tees** — Nominal 4 feet long, 1<sup>1</sup>/<sub>2</sub>-inch-wide face, installed perpendicular to the main runners, spaced 16 inches on center. Additional cross tees or cross channels used at 8 inches from each side of butted gypsum panel end joints. The cross tees or cross channels may be riveted or screw attached to the wall angle or channel to facilitate the ceiling installation.

c. **Cross Channels** — Nominal 4 or 12 feet long, installed perpendicular to main runners, spaced 16 inches on center. When Batts and Blankets (Item 5) are used, cross channels spaced 16 inches on center.

d. **Wall Angle or Channel** — Painted or galvanized steel angle with 1-inch legs or channel with 1-inch legs, 1<sup>9</sup>/<sub>16</sub>-inch-deep attached to walls at perimeter of ceiling with fasteners 16 inches on center. To support steel framing member ends and for screw-attachment of the gypsum panels.

CGC INC — Type DGL or RX

USG INTERIORS LLC — Type DGL or RX

**5. Gypsum Board\*** — Two layers of 1/2 inch or 5/8-inch-thick by 4 feet wide gypsum panels, installed perpendicular to resilient channels (Item 4). The base layer of panels screw-attached to the resilient channels with 1-inch-long Type S screws spaced 8 inches on center at the butt joints and 16 inches on center in the field of the panel. The face layer screw-attached to the resilient channels with 1<sup>5</sup>/<sub>8</sub> inch. Type S screws spaced 8 inches on center and 1<sup>1</sup>/<sub>2</sub>-inch Type G screws spaced 8 inches on center at the butt joints located mid-span between resilient channels.

When **Steel Framing Members** (Item 4A) are used, gypsum board installed with long dimension perpendicular to cross tees. The base layer of panels fastened to cross tees with 1-inch long Type S screws spaced 8 inches on center at the butt joints and 16 inches on center in the field of the panel. The face layer screw-attached to the cross tees with 1<sup>5</sup>/<sub>8</sub>-inch Type S screws spaced 8 inches on center and 1<sup>1</sup>/<sub>2</sub>-inch Type G screws spaced 8 inches on center at the butt joints located mid-span between cross tees. Screws along sides and ends of panels spaced 3/8 to 1/2 inch from panel edge. End joints of panels shall be staggered with spacing between joints on adjacent panels not less than 4 feet on center.

CGC INC — 1/2-inch Type C, IP-X2, IPC-AR; 5/8-inch Type C, SCX, IP-X1, IP-X2, ULIX

GEORGIA-PACIFIC GYPSUM L L C — Types 5, DAPC, TG-C

UNITED STATES GYPSUM CO — 1/2-inch Type C, IP-X2, IPC-AR; 5/8-inch Type C, SCX, IP-X1, IP-X2, ULIX

USG MEXICO S A DE C V — 1/2-inch Type C, IP-X2, IPC-AR; 5/8-inch Type C, SCX, IP-X1, IP-X2

**6. Finishing System** — (Not shown) — Fiber tape embedded in compound over joints and exposed nail heads, covered with compound with edges of compound feathered out. As an alternate, nominal 3/32-inch-thick gypsum veneer plaster may be applied to the entire surface of classified veneer baseboard. Joints reinforced.

**Fire Resistance Ratings - ANSI/UL 263  
Unrestrained Assembly Rating — 1 Hour**

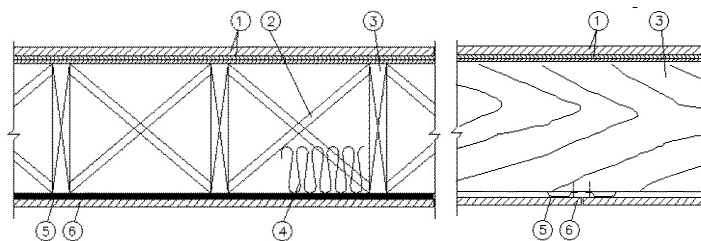

Where noted with an “\*” in the description below, the product must bear the UL Classification Mark.

**FIGURE 2—1-HOUR FLOOR/CEILING ASSEMBLY CONSTRUCTED WITH DIMENSIONAL WOOD JOISTS**

For SI Units: 1 inch = 25.4 mm, 1 foot = 0.3048 m, 1 pound = 4.45 N

**1. Flooring System** — The flooring system shall consist of the following:

**Subflooring** — Nominal 1<sup>5</sup>/<sub>32</sub> inches thick wood structural panels installed perpendicular to the joists with end joints staggered. Plywood or panels secured to joists with construction adhesive and No. 6d ringed shank nails, spaced 12 inches on center along each joist. Staples having equal or greater withdrawal and lateral resistance strength may be substituted for the 6d nails.

**Vapor Barrier** — (Optional) - Nominal 0.010-inch-thick commercial asphalt saturated felt.

**Finish Flooring\*** — Floor Topping Mixture — Minimum 3/4-inch thickness of floor topping mixture having a minimum compressive strength of 1800 psi. Refer to manufacturer's instructions accompanying the material for specific mix design.

UNITED STATES GYPSUM CO — Types LRK, HSLRK, CSD

USG MEXICO S A DE C V — Types LRK, HSLRK, CSD

**Floor Mat Materials\*** — (Optional) — Floor mat material loose laid over the subfloor. Refer to manufacturer's instructions regarding the minimum thickness of floor topping over each floor mat material.

UNITED STATES GYPSUM CO — Types SAM, LEVELROCK<sup>®</sup> Brand Sound Reduction Board, LEVELROCK<sup>®</sup> Brand Floor Underlayment SRM-25

**2. Cross Bridging** — 1 by 3 inches.

**3. Wood Joists** — 2 by 10 inches, spaced 16 inches on center, firestopped. Spacing may increase to 24 inches on center when Item 7, Battens, are used.

**4. Batts and Blankets\*** — (Optional) — Glass fiber or mineral wool insulation bearing the UL Classification Marking as to Surface Burning Characteristics and/or Fire Resistance. - When the resilient channels (Item 5) are spaced 16 inches on center, the insulation shall be a maximum of 3<sup>1</sup>/<sub>2</sub> inches thick, and shall be secured against the subflooring with staples at 12 inches on center or held suspended in the concealed space with 0.090 inch diameter galvanized steel wires attached to the wood trusses at 12 inches on center. When the resilient channels (Item 5) are spaced a maximum of 12 inches on center or when the Steel Framing Members (Item 5A) are used, there is no limit in the overall thickness of insulation, and the insulation can be secured against the subflooring, held suspended in the concealed space or draped over the resilient channels (or Steel Framing Members) and gypsum panel membrane.

**4A. Loose Fill Material\*** — As an alternate to Item 4, when the resilient channels (Item 5) are spaced a maximum of 12 inches on center or when the Steel Framing Members (Item 5A) are used - Any loose fill material bearing the UL Classification Marking for Surface Burning Characteristics. There is no limit in the overall thickness of insulation.

**5. Furring Channels** — Resilient channels formed of 25 MSG thick galvanized steel. Installed perpendicular to the wood joists, spaced a maximum of 24 inches on center when no insulation is fitted in the concealed space. Otherwise, the spacing shall be as specified under Item 4 or 4A. Two courses of resilient channel positioned 6 inches on center at gypsum panel butt-joints (3 inches from each end of panel). Channels oriented opposite at panel butt-joints. Channel splices overlapped 4 inches beneath wood trusses. Channels secured to each truss with 1<sup>1</sup>/<sub>4</sub>-inch-long Type S screws.

**5A. Alternate Steel Framing Members** — (Not Shown) — As an alternate to Item 5, main runners, cross tees, cross channels and wall angle as listed below:

a. **Main Runners** — Nominal 10 or 12 feet long, <sup>15</sup>/<sub>16</sub> inch or 1<sup>1</sup>/<sub>2</sub>-inch-wide face, spaced 4 feet on center. Main runners suspended by minimum 12 SWG galvanized steel hanger wires spaced 48 inches on center. Hanger wires to be located adjacent to main runner/cross tee intersections. Hanger wires wrapped and twist-tied on 16d nails driven into side of joists at least 5 inches above the bottom face.

b. **Cross Tees** — Nominal 4 feet long, 1<sup>1</sup>/<sub>2</sub>-inch-wide face, installed perpendicular to the main runners, spaced 16 inches on center. Additional cross tees or cross channels used at 8 inches from each side of butted gypsum panel end joints. The cross tees or cross channels may be riveted or screw attached to the wall angle or channel to facilitate the ceiling installation.

c. **Cross Channels** — Nominal 4 or 12 feet long, installed perpendicular to main runners, spaced 16 inches on center.

d. **Wall Angle or Channel** — Painted or galvanized steel angle with 1-inch legs or channel with 1-inch legs, <sup>9</sup>/<sub>16</sub>-inch-deep attached to walls at perimeter of ceiling with fasteners 16 inches on center. To support steel framing member ends and for screw-attachment of the gypsum panels.

CGC INC — Type DGL or RX

USG INTERIORS LLC — Type DGL or RX

**6. Gypsum Board\*** — Nominal <sup>5</sup>/<sub>8</sub>-inch-thick, 48 inches wide gypsum panels. When resilient channels (Items 5) are used, gypsum panels installed with long dimension perpendicular to resilient channels. Gypsum panels secured with 1-inch-long Type S bugle head steel screws spaced 12 inches on center and located a minimum of <sup>1</sup>/<sub>2</sub> inch from side joints and 3 inches from end joints. End joints secured to both resilient channels as shown in end joint detail.

CGC INC — Types C, IP-X2, IPC-AR.

UNITED STATES GYPSUM CO — Types C, IP-X2, IPC-AR.

USG BORAL DRYWALL SFZ LLC — Type C

**7. Battens** — Nominal 6 by 22<sup>1</sup>/<sub>2</sub> by <sup>5</sup>/<sub>8</sub>-inch-thick pieces of gypsum board (Item 6) centered under subfloor joints and fastened with staples spaced 7 inches on center along each edge. Staples formed of 16 SWG (0.062-inch-thick) steel with 1<sup>1</sup>/<sub>8</sub> inches legs and <sup>1</sup>/<sub>2</sub>-inch crown, driven flush with gypsum board batten strips. The battens and staples are optional when the finish flooring consists of Floor Topping Mixture\*.

**Fire Resistance Ratings - ANSI/UL 263  
Unrestrained Assembly Rating — 1 Hour**

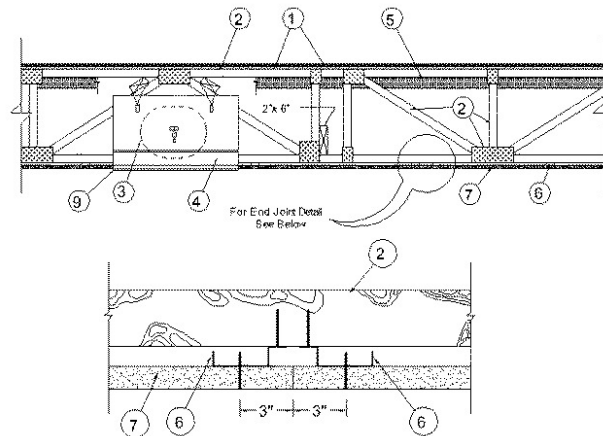

Where noted with an “\*\*” in the description below, the product must bear the UL Classification Mark.

**FIGURE 3—1-HOUR FLOOR/CEILING ASSEMBLY CONSTRUCTED WITH OPEN WEB WOOD TRUSSES**

For SI Units: 1 inch = 25.4 mm, 1 foot = 0.3048 m, 1 pound = 4.45 N

**1. Flooring System** — The flooring system shall consist of the following:

**Subflooring** — Nominal  $\frac{23}{32}$  inches thick wood structural panels installed perpendicular to trusses with end joints staggered. Plywood or panels secured to trusses with construction adhesive and No. 6d ringed shank nails, spaced 12 inches on center along each truss. Staples having equal or greater withdrawal and lateral resistance strength may be substituted for the 6d nails.

**Vapor Barrier** — (Optional) - Nominal 0.030-inch-thick commercial asphalt saturated felt.

**Finish Flooring\*** — Floor Topping Mixture — Minimum  $\frac{3}{4}$ -inch thickness of floor topping mixture having a minimum compressive strength of 1800 psi. Refer to manufacturer's instructions accompanying the material for specific mix design.

UNITED STATES GYPSUM CO — Types LRK, HSLRK, CSD

USG MEXICO S A DE C V — Types LRK, HSLRK, CSD

**Floor Mat Materials\*** — (Optional) — Floor mat material loose laid over the subfloor. Refer to manufacturer's instructions regarding the minimum thickness of floor topping over each floor mat material.

UNITED STATES GYPSUM CO — Types SAM, LEVELROCK<sup>®</sup> Brand Sound Reduction Board, LEVELROCK<sup>®</sup> Brand Floor Underlayment SRM-25

**2. Trusses** — Parallel chord trusses, spaced a max of 24 inches on center, fabricated from nominal 2 by 4 inches lumber, with lumber oriented vertically or horizontally. Minimum truss depth is 12 inches when no Ceiling Damper\* is used and 18 inches when a Ceiling Damper\* is used. Truss members secured together with minimum 0.0356-inch-thick galvanized steel plates. Plates have  $\frac{5}{16}$ -inch-long teeth projecting perpendicular to the plane of the plate. The teeth are in pairs facing each other (made by the same punch), forming a split tooth type plate. Each tooth has a chisel point on its outside edge. These points are diagonally opposite each other for each pair. The top half of each tooth has a twist for stiffness. The pairs are repeated on approximately  $\frac{7}{8}$ -inch centers with four rows of teeth per inch of plate width.

**3. Air Duct\*** — Any UL Class 0 or Class 1 flexible air duct installed in accordance with the instructions provided by the damper manufacturer.

**4. Ceiling Damper\*** — For use with minimum 18 inches deep trusses. Maximum nominal area shall be 324 square inches with the length not to exceed 24 inches and the width not to exceed 20 inches. Maximum height of damper shall be 14 inches. Aggregate damper openings shall not exceed 162 square inches per 100 square feet of ceiling area. Damper installed in accordance with the manufacturer's installation instructions provided with the damper. A steel grille (Item 9) shall be installed in accordance with installation instructions.

C&S AIR PRODUCTS — Model RD-521

POTTORFF — Model CFD-521

**5. Batts and Blankets\*** — (Optional) — Glass fiber or mineral wool insulation bearing the UL Classification Marking as to Surface Burning Characteristics and/or Fire Resistance. When the resilient channels (Item 6) are spaced 24 inches on center, no insulation shall be installed in the concealed space. When the resilient channels (Item 6) are spaced 16 inches on center, the insulation shall be a maximum of  $3\frac{1}{2}$  inches thick, and shall be secured against the subflooring with staples at 12 inches on center or held suspended in the concealed space with 0.090 inch diameter galvanized steel wires attached to the wood trusses at 12 inches on center. When the resilient channels (Item 6) are spaced a maximum of 12 inches on center are used, there is no limit in the overall thickness of insulation, and the insulation can be secured against the subflooring, held suspended in the concealed space or draped over the resilient or furring channels (or Steel Framing Members) and gypsum panel membrane.

**5D. Cavity Insulation - Batts and Blankets\* or Fiber, Sprayed\*** — (As described above in Item 5) — (For Use with Item 7A, Not Shown) — Minimum  $3\frac{1}{2}$  inches thick with no limit on maximum thickness fitted in the concealed space, draped over the resilient channel (Item 6H)/gypsum board (Item 7A) ceiling membrane.

**6. Resilient Channels** — Formed from minimum 25 MSG galvanized steel installed perpendicular to trusses. When there is no insulation installed in the concealed space the resilient channels are spaced 24 inches on center. When insulation (Item 5) is secured to the underside of the subfloor the resilient channels are spaced 16 inches on center. When insulation, Item 5, is applied over the resilient channel/gypsum panel ceiling membrane, the resilient channels are spaced 12 inches on center. Channels secured to each truss with  $1\frac{1}{4}$  inches long Type S bugle

head steel screws. Channels overlapped 4 inches at splices. Two channels, spaced 6 inches on center, oriented opposite each gypsum panel end joint as shown in the above illustration. Additional channels shall extend minimum 6 inches beyond each side edge of panel.

**6H. Resilient Channels** — For Use With Item 7A - Formed from minimum 25 MSG galvanized steel installed perpendicular to trusses and spaced 16 inches on center. Channels secured to each truss with 1<sup>5</sup>/<sub>8</sub> inches long Type S bugle head steel screws. Channels overlapped 4 inches at splices. Two channels, spaced 6 inches on center, oriented opposite each gypsum panel end joint. Additional channels shall extend minimum 6 inches beyond each side edge of panel. Insulation, Item 5D is applied over the resilient channel/gypsum panel ceiling membrane.

**7. Gypsum Board\*** — Nominal 5/8-inch-thick, 48 inches wide gypsum panels. When resilient channels (Item 6) are used, gypsum panels installed with long dimension perpendicular to resilient channels. Gypsum panels secured with 1-inch-long Type S bugle head steel screws spaced 12 inches on center and located a minimum of 1/2 inch from side joints and 3 inches from the end joints. When insulation (Item 5) is applied over the resilient channel/gypsum panel ceiling membrane screw spacing shall be reduced to 8 inches on center. End joints secured to both resilient channels as shown in end joint detail.

- CGC INC — Types C, IP-X2, IPC-AR
- UNITED STATES GYPSUM CO — Types C, IP-X2, IPC-AR
- USG BORAL DRYWALL SFZ LLC — Type C
- USG MEXICO S A DE C V — Types C, IP-X2, IPC-AR

**7A. Gypsum Board\*** — For use with Items 5D and 6H. Nominal 5/8-inch-thick, 48 inches wide gypsum panels installed with long dimension perpendicular to resilient channels. Gypsum panels secured with 1-inch-long Type S bugle head steel screws spaced 8 inches on center and located a minimum of 1/2 inch from side joints and 3 inches from the end joints. Finish Rating with this ceiling system is 20 minutes.

- CGC INC — Type ULIX
- UNITED STATES GYPSUM CO — Type ULIX

**8. Finishing System** — (Not Shown) — Vinyl, dry or premixed joint compound, applied in two coats to joints and screw-heads. Nominal 2 inches wide paper tape embedded in first layer of compound over all joints. As an alternate, nominal 3/32-inch-thick veneer plaster may be applied to the entire surface of gypsum board.

**9. Grille** — Grille installed in accordance with the installation instructions provided with the ceiling damper.

**Fire Resistance Ratings - ANSI/UL 263  
Unrestrained Assembly Rating — 1 Hour or 2 Hour**

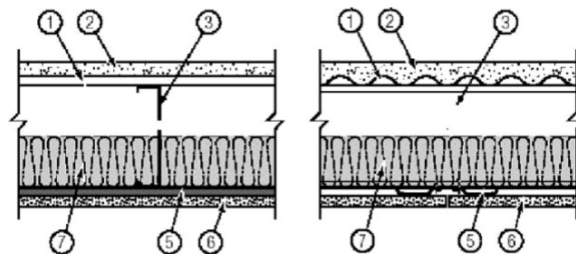

Where noted with an “\*\*” in the description below, the product must bear the UL Classification Mark.

**FIGURE 4—1-HOUR FLOOR/CEILING ASSEMBLY CONSTRUCTED WITH STEEL JOISTS**

For SI Units: 1 inch = 25.4 mm, 1 foot = 0.3048 m, 1 pound = 4.45 N

**1. Steel Deck** — Minimum 9/16-inch-deep, 22 MSG galvanized corrugated fluted steel deck. Overlapped one corrugation at each side and attached to each joist with 5/8-inch-long #10-16 TEK screws at each side joint and no more than 12 inches on center between sides.

**2. Floor Topping Mixture\*** — Compressive strength to be 2500 psi minimum. Minimum thickness to be 1 inch as measured from the top plane of the deck or the top plane of the Floor Mat Material\*. When 6 inches or 8 inches deep steel joists are used, floor topping mixture is to be a minimum of 1<sup>1</sup>/<sub>8</sub> inches thick. Refer to manufacturer’s instructions accompanying the material for specific mix design. An ethylene vinyl acetate adhesive may be applied to the steel deck prior to the installation of the floor topping mixture at a maximum application rate of 0.025 lbs./ft<sup>2</sup>.

- UNITED STATES GYPSUM CO — Type CSD, LRK, HSLRK
- USG MEXICO S A DE C V — Types LRK, HSLRK, CSD

**Floor Mat Materials\*** — (Optional) - Floor mat material loose laid over the crests of the steel deck. Refer to manufacturer’s instructions regarding the minimum thickness of floor topping over each floor mat material.

- UNITED STATES GYPSUM CO — Types SAM, LEVELROCK® Brand Sound Reduction Board, LEVELROCK® Brand Floor Underlayment SRM-25.

**Alternate Floor Mat Materials\*** — (Optional) — Not Shown — Floor mat material loose laid over the crests of the steel deck. The flutes of the deck are not required to be filled prior to installation of sound mat. Minimum 1<sup>3</sup>/<sub>8</sub> inches thick floor topping mixture applied over the floor mat. When 6 inches or 8 inches steel joists are used and the flutes are not filled, Minimum 1<sup>1</sup>/<sub>2</sub> inches thick floor topping mixture applied over the sound mat.

- UNITED STATES GYPSUM CO — Type SAM CSD

**3. Steel Joists** — C shaped galvanized steel sections with minimum 8 inches deep, minimum 1<sup>9</sup>/<sub>16</sub> inches flanges and minimum 3/8-inch stiffening flanges, fabricated from minimum No. 16 MSG galvanized steel with a minimum yield strength of 33 ksi. When the clear span is a maximum of 8 feet and when fabricated from minimum No. 18 MSG, the minimum depth is 6 inches. The web of each joist may be provided with circular or oval knockouts at the joist mid-depth. Knockouts spaced minimum 48 inches on center. Joists spaced max 24 inches on center. Joists attached to joist rim with three 3/4-inch-long self-drilling #10-16 TEK screws through tab to the outside of the web. At joist rim splices bearing on

supports, joists rims are connected using an overlapping section of a 12 inches long splice plate (a joist piece), with four  $\frac{3}{4}$ -inch-long self-drilling #10-16 TEK screws to each rim piece.

**4. Joist Bridging** — Not shown — Installed immediately after joists are erected and before construction loads are applied. The bridging consists of minimum  $1\frac{1}{4}$  inches deep,  $2\frac{3}{4}$  inches wide and  $21\frac{3}{4}$  inches long, formed galvanized steel installed in a staggered formation a maximum of every 8 feet along the joist span. Bridging secured to joist bottom flange with one  $\frac{3}{4}$ -inch-long self-drilling #10-16 TEK screw at each end tab. Minimum coated steel thickness for bridging is 0.048 inch. Solid blocking must be provided in the two end joist bays and a maximum of 8 feet on center (every 4 joist spaces). Solid blocking consisting of cut to length joist sections secured to the joists with clips. Clips are minimum 4 inches by  $1\frac{1}{2}$  inches by 7 inches long, 0.054-inch-thick, 50 ksi yield strength and secured with two  $\frac{3}{4}$ -inch-long self-drilling #10-16 TEK screws per leg.

**5. Resilient Channels** —  $\frac{1}{2}$ -inch-deep, formed of 25 MSG galvanized steel, spaced 12 inches on center perpendicular to joists. Channels oriented opposite at wallboard butt-joints. Channel splices overlapped 4 inches beneath steel joists. Channels secured to each joist with  $\frac{1}{2}$  inch. Type S-12 low profile screws. Channels oriented opposite at wallboard butt joints (spaced 6 inches on center) as shown in the above illustration.

**5A. Alternate Steel Framing Members** — (Not Shown) - For the 1 Hour Rating Only - As an alternate to Item 5, main runners, cross tees, cross channels and wall angle as listed below:

a. **Main Runners** — Nominal 10 or 12 feet long,  $\frac{15}{16}$  inch or  $1\frac{1}{2}$  inches wide face, spaced 4 feet on center. Main runners suspended by minimum 12 SWG galvanized steel hanger wires spaced 48 inches on center. Hanger wires to be located adjacent to main runner/cross tee intersections. Hanger wires inserted through holes drilled through web of joists and twist-tied.

b. **Cross Tees** — Nominal 4 feet long,  $1\frac{1}{2}$  inches wide face, installed perpendicular to the main runners, spaced 16 inches on center. Additional cross tees or cross channels used at 8 inches from each side of butted gypsum panel end joints. The cross tees or cross channels may be riveted or screw attached to the wall angle or channel to facilitate the ceiling installation.

c. **Cross Channels** — Nominal 4 or 12 feet long, installed perpendicular to main runners, spaced 16 inches on center.

d. **Wall Angle or Channel** — Painted or galvanized steel angle with 1-inch legs or channel with 1-inch legs,  $\frac{9}{16}$  inches deep attached to walls at perimeter of ceiling with fasteners 16 inches on center. To support steel framing member ends and for screw-attachment of the gypsum panel.

CGC INC — Type DGL or RX

USG INTERIORS LLC — Type DGL or RX

**5B. Steel Framing Members\*** — (Optional, Not Shown) — As an alternate to Item 5 — Furring channels and Steel Framing Members as described below:

a. **Furring channels** — Formed of No. 25 MSG galvanized steel,  $2\frac{3}{8}$  inches wide by  $\frac{7}{8}$ -inch-deep, spaced 12 inches on center, perpendicular to joists (Item 3). Channel secured to joists as described in Item b. Ends of adjoining channels overlapped 6 inches and tied together with double strand of No. 18 SWG galvanized steel wire near each end of overlap. Additional channels shall be positioned so that the distance from the end of the board to the center of the first channel is 3 inches and from the board end to the center of the next channel is 12 inches.

b. **Cross Tees** — Used to attach furring channels (Item a) to joists (Item 3). Clips spaced 24 inches on center and secured to the bottom chord of joists with minimum  $1\frac{5}{8}$  inches long No. 8 self-drilling, self-tapping, bugle, flat or hex head screw through the center grommet. Furring channels are friction fitted into clips. Additional clips required to hold furring channel that supports the gypsum board butt joints.

PLITEQ INC — Type Genie Clip

**6. Gypsum Board\*** — Nominal  $\frac{5}{8}$ -inch-thick, 48 inches wide gypsum panels. When resilient channels (Item 5) or furring channels (Item 5B(a)) are used, gypsum panels installed with long dimension perpendicular to resilient channels or furring channels. Gypsum panels secured with 1-inch-long Type S bugle-head screws spaced 8 inches on center in both the field and the perimeter, and  $1\frac{1}{2}$  inches from side edges of the board. When Steel Framing Members (Item 5A) are used, gypsum panels installed with long dimension perpendicular to cross tees with side joints centered along main runners and end joints centered along cross tees. Panels fastened to cross tees with 1-inch-long Type S bugle-head screws spaced 8 inches on center in the field and along end joints. Panels fastened to main runners with 1-inch-long Type S bugle-head screws spaced midway between cross tees. Screws along sides and ends of panels spaced  $\frac{3}{8}$  to  $\frac{1}{2}$  inch from panel edge. End joints of panels shall be staggered with spacing between joints on adjacent panels not less than 2 feet on center.

CGC INC — Types C, IP-X2, IPC-AR, ULIX

UNITED STATES GYPSUM CO — Types C, IP-X2, IPC-AR, ULIX

USG BORAL DRYWALL SFZ LLC — Type C

USG MEXICO S A DE C V — Types C, IP-X2, IPC-AR

**7. Batts and Blankets\*** — Mineral wool or glass fiber insulation, minimum  $3\frac{1}{2}$  inches thick, bearing the UL Classification Marking for Surface Burning Characteristics. Insulation fitted in the concealed space, draped over the resilient channel/gypsum panel or Steel Framing Members/gypsum panel ceiling membrane.

**8. Joint System** — Not Shown — Vinyl, dry or premixed joint compound, applied in two coats to joints and screw heads; paper tape, 2 inches wide, embedded in first layer of compound over all joints.

**Fire Resistance Ratings - ANSI/UL 263**  
**Restrained Assembly Rating — 2 Hour**  
**Unrestrained Assembly Rating — 1½ Hour**

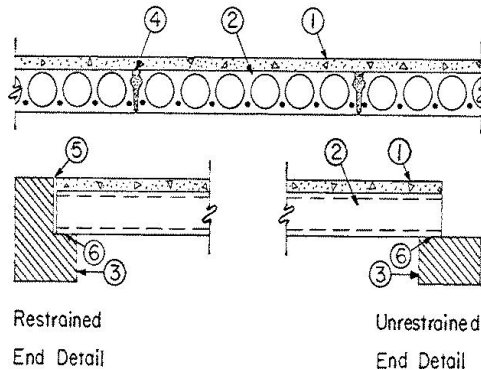

Where noted with an “\*” in the description below, the product must bear the UL Classification Mark.

**FIGURE 5—1-HOUR FLOOR/CEILING ASSEMBLY CONSTRUCTED WITH PRECAST CONCRETE UNITS**

For SI Units: 1 inch = 25.4 mm, 1 foot = 0.3048 m, 1 pound = 4.45 N

**1. Floor Topping Mixture\*** — Compressive strength to be 1800 psi minimum. Minimum thickness to be ¾ inch. Refer to manufacturer’s instructions accompanying the material for specific mix design.

UNITED STATES GYPSUM CO — Type CSD, LRK, HSLRK

USG MEXICO S A DE C V — Types LRK, HSLRK, CSD

**Floor Mat Materials\*** — (Optional) - Floor mat material loose laid over the subfloor. Refer to manufacturer’s instructions regarding the minimum thickness of floor mat material over each floor mat material.

UNITED STATES GYPSUM CO — Types SAM, LEVELROCK® Brand Sound Reduction Board, LEVELROCK® Brand Floor Underlayment SRM-25

**2. Precast Concrete Units\*** — Nom 8, 10, 12 or 14 inches thick units. Normal weight aggregate. Cross section similar to the above illustration.

BOCELLA PRECAST LLC  
 HOLLOWCORE INC  
 SEQUATCHIE CONCRETE SERVICE INC  
 STRES CORE INC

**3. End Details** — Restrained and unrestrained.

**4. Joint** — Clearance between slabs at bottom, full length, 1/16 inch minimum, 5/16 inch maximum, grouted full length with sand-cement grout (3500 psi minimum compressive strength) to a maximum depth of 4½ inches. This depth may be maintained by placing a compressible material in the bottom of the joint before applying grout.

Note: — A ¾-inch lateral expansion joint to be provided the full length and depth of the slabs every 14 feet. Expansion should be obtained with noncombustible, compressible material, for example, 24 sheets of 1/16 inch thick ceramic fiber paper (total thickness equals 1½ inches).

**5. End Clearance** — Clearance for expansion at each end of slabs shall be equal to (3/16 + or - 1/16 in.) L/17 inch, where "L" is equal to length of span in feet.

**6. Min Bearing** — 1½ inches

**TABLE 3—SOUND TRANSMISSION RATED FLOOR/CEILING ASSEMBLIES CONSTRUCTED WITH WOOD I-JOIST**

ASSEMBLY	GYPSUM	RESILIENT CHANNEL	INSULATION	WOOD I-JOIST SUPPORTS	SUBFLOOR	SOUND MAT	GYPSUM CONCRETE	FLOOR TOPPING	STC/IIC RATING	
1	Two layers of 5/8-inch Type X ASTM C1396 gypsum board fastened to resilient channel 12 inches o.c. with 1-inch-long Type S screws	Resilient channel spaced 16 inches o.c. perpendicular to supports and fastened at each support	3 1/2-inch fiberglass batt insulation installed in the cavities	12-inch deep wood I-joists spaced 24 inches o.c.	3/4-inch OSB adhered and attached with fasteners to wood I-joists supports	SAM-N25™	1 inch	Levelrock 2500	None	STC 55
2									0.125-inch-thick vinyl planks	IIC 52
3									10.5 mm thick ceramic tiles with a 0.8 mm thick sheet membrane	STC 62 IIC 56

For SI: 1 inch = 25.4 mm.

**TABLE 4—SOUND TRANSMISSION RATED FLOOR/CEILING ASSEMBLIES CONSTRUCTED WITH DIMENSIONAL WOOD JOISTS**

ASSEMBLY	GYPSUM	RESILIENT CHANNEL	INSULATION	DIMENSIONAL WOOD JOISTS SUPPORTS	SUBFLOOR	SOUND MAT	GYPSUM CONCRETE	FLOOR TOPPING	STC/IIC RATING	
4	One layer of 5/8-inch Type X ASTM C1396 gypsum board fastened to resilient channel 12 inches o.c. with 1-inch-long Type S screws	Resilient channel spaced 24 inches o.c. perpendicular to supports and fastened at each support	3 1/2-inch fiberglass batt insulation installed in the cavities	Nominal 2-inch by 10-inch wood lumber spaced 16 inches o.c.	5/8-inch OSB adhered and attached with fasteners to dimensional wood joists	SAM-N25™	1 inch	Levelrock 2500	None	STC 55
5									0.125-inch-thick vinyl planks	IIC 54
6									5/16-inch-thick ceramic tiles	IIC 50

For SI: 1 inch = 25.4 mm.

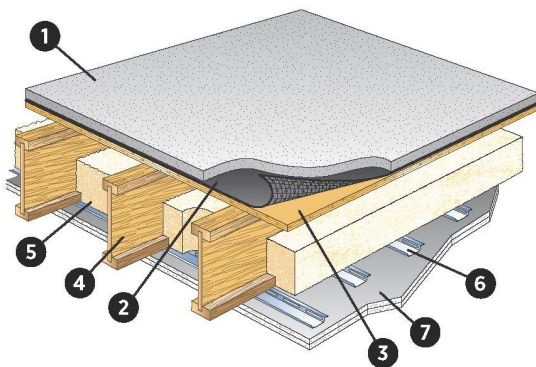

1. Levelrock 2500
2. SAM-N25™ Sound Mat
3. Subfloor
4. I-joists
5. Insulation
6. Resilient Channels
7. Gypsum Board
8. Finish System (not shown)

**FIGURE 6—SOUND TRANSMISSION RATED FLOOR/CEILING ASSEMBLY—SEE TABLE 3 FOR ASSEMBLIES 1—3**

1. Levelrock 2500

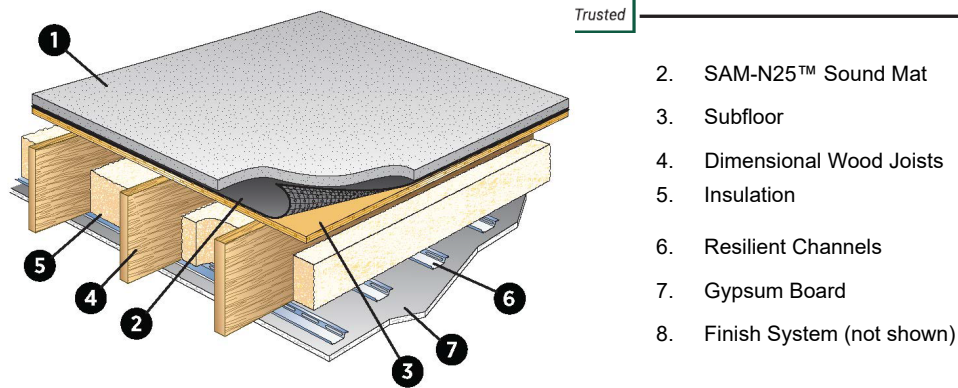

FIGURE 7—SOUND TRANSMISSION RATED FLOOR/CEILING ASSEMBLY—SEE TABLE 4 FOR ASSEMBLIES 4—6

TABLE 5—SOUND TRANSMISSION RATED FLOOR/CEILING ASSEMBLIES CONSTRUCTED WITH OPEN WEB WOOD TRUSSES

ASSEMBLY	GYPSUM	RESILIENT CHANNEL	INSULATION	SUPPORTS	SUBFLOOR	SOUND MAT	GYPSUM CONCRETE		FLOOR TOPPING	STC/IIC RATING
7	One layer of 5/8-inch USG SHEETROCK Brand FIRECODE Type C Core gypsum board or one layer of 5/8-inch USG SHEETROCK Brand EcoSmart FIRECODE X Gypsum Panel fastened to resilient channel 12 inches o.c. with 1-inch-long Type S screws	Resilient channel spaced 16 inches o.c. perpendicular to supports and fastened at each support	3 1/2-inch fiberglass batt insulation installed in the cavities	Nominal 4-inch by 18-inch deep open web wood truss spaced 24 inches o.c.	3/4-inch OSB adhered and attached with fasteners to open web wood trusses	SAM-N25™	1 inch	Levelrock 2500	None	STC 58 IIC 52
8	One layer of 5/8-inch USG SHEETROCK Brand FIRECODE Type C Core gypsum board or one layer of 5/8-inch USG SHEETROCK Brand EcoSmart FIRECODE X Gypsum Panel fastened to resilient channel 12 inches o.c. with 1-inch-long Type S screws	Resilient channel spaced 16 inches o.c. perpendicular to supports and fastened at each support	3 1/2-inch fiberglass batt insulation installed in the cavities	Nominal 4-inch by 18-inch deep open web wood truss spaced 24 inches o.c.	3/4-inch OSB adhered and attached with fasteners to open web wood trusses	SAM-N25™	1 inch	Levelrock 2500	0.08-inch-thick vinyl tile	STC 57 IIC 53

For SI: 1 inch = 25.4 mm.

TABLE 6—SOUND TRANSMISSION RATED FLOOR/CEILING ASSEMBLIES CONSTRUCTED WITH STEEL JOISTS

ASSEMBLY	GYPSUM	RESILIENT CHANNEL	INSULATION	STEEL JOISTS SUPPORTS	STEEL DECK	SOUND MAT	GYPSUM CONCRETE		FLOOR TOPPING	STC/IIC RATING
9	One layer of 5/8-inch USG SHEETROCK Brand FIRECODE Type C Core gypsum board fastened to resilient channel 12 inches o.c. with 1-inch-long Type S screws	Resilient channel spaced 16 inches o.c. perpendicular to supports and fastened	3 1/2-inch fiberglass batt insulation installed in the cavities	10-inch-deep, 2-inch flange, 5/8-inch stiffening flange, minimum 16 gauge steel joist	9/16-inch deep, 22-gauge Type S corrugated fluted steel deck fastened to the steel joist at 12 inches o.c. The flutes of the steel deck are filled with gypsum concrete.	SAM-N25™	1 inch	Levelrock CSD Early Exposure	0.26-inch-thick vinyl plank	STC 59 IIC 53
10	One layer of 5/8-inch USG SHEETROCK Brand FIRECODE Type C Core gypsum board fastened to resilient channel 12 inches o.c. with 1-inch-long Type S screws	Resilient channel spaced 16 inches o.c. perpendicular to supports and fastened	3 1/2-inch fiberglass batt insulation installed in the cavities	10-inch-deep, 2-inch flange, 5/8-inch stiffening flange, minimum 16 gauge steel joist	9/16-inch deep, 22-gauge Type S corrugated fluted steel deck fastened to the steel joist at 12 inches o.c. The flutes of the steel deck are filled with gypsum concrete.	SAM-N25™	1 inch	Levelrock CSD Early Exposure	7.3 mm thick ceramic tiles with a 0.8 mm thick sheet membrane	STC 60 IIC 52

For SI: 1 inch = 25.4 mm.

1. Levelrock 2500

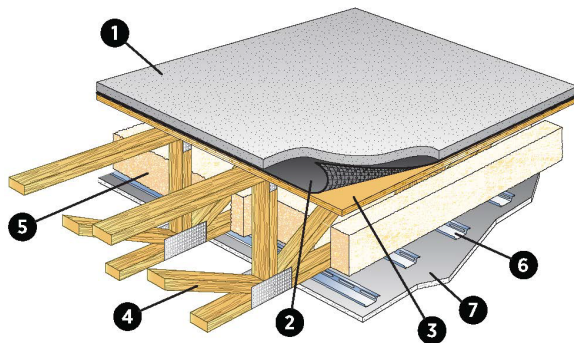

2. SAM-N25™ Sound Mat
3. Subfloor
4. Open Web Wood Trusses
5. Insulation
6. Resilient Channels
7. Gypsum Board
8. Finish System (not shown)

FIGURE 8—SOUND TRANSMISSION RATED FLOOR/CEILING ASSEMBLY—SEE TABLE 5 FOR ASSEMBLIES 7—8

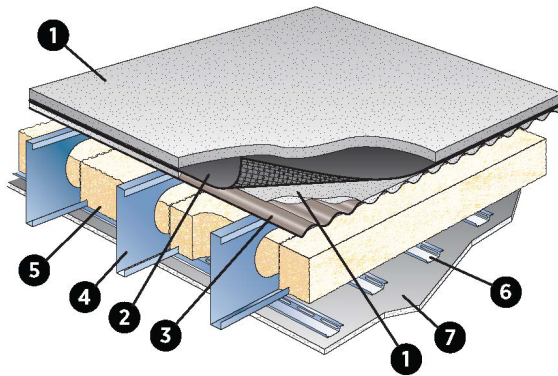

1. Levelrock CSD Early Exposure
2. SAM-N25™ Sound Mat
3. Corrugated Steel Deck
4. Steel Joists
5. Insulation
6. Resilient Channels
7. Gypsum Board
8. Finish System (not shown)

FIGURE 9—SOUND TRANSMISSION RATED FLOOR/CEILING ASSEMBLY—SEE TABLE 6 FOR ASSEMBLIES 9—10

TABLE 7—SOUND TRANSMISSION RATED FLOOR/CEILING ASSEMBLIES CONSTRUCTED WITH PRECAST CONCRETE UNITS

ASSEMBLY	CONCRETE	SOUND MAT	GYPSUM CONCRETE		FLOOR TOPPING	STC/IIC RATING
11	8-inch thick hollow-core concrete	SAM-N12™	3/4 inch	Levelrock 3500	0.22-inch-thick vinyl planks	STC 55 IIC 51
12					10.5 mm thick ceramic tiles with a 0.8 mm thick sheet membrane	STC 57 IIC 51

For SI: 1 inch = 25.4 mm.

TABLE 8—SOUND TRANSMISSION RATED FLOOR/CEILING ASSEMBLY CONSTRUCTED WITH CROSS LAMINATED TIMBER

ASSEMBLY	CROSS LAMINATED TIMBER	SOUND MAT	GYPSUM CONCRETE		FLOOR TOPPING	STC/IIC RATING
13	6.89-inch-thick cross laminated timber	SAM-N25™ Ultra	2 inches	Levelrock 2500	0.27-inch-thick vinyl planks	STC 56 IIC 53
					0.43-inch-thick ceramic tiles over 1 mm thick NobleSeal CIS	STC 55 IIC 50
					0.32-inch-thick engineered hardwood	STC 56 IIC 50

For SI: 1 inch = 25.4 mm.

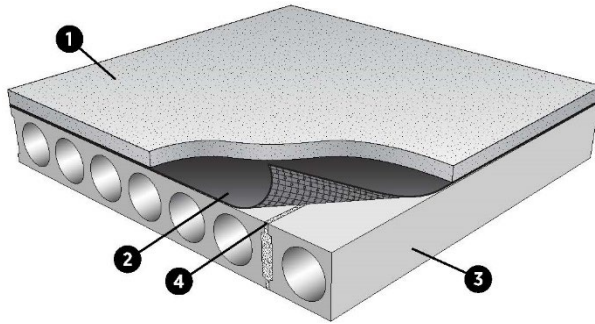

1. Levelrock 3500
2. SAM-N12™ Sound Mat
3. Precast Concrete Units
4. Grouted Expansion Joint
5. Finish System (not shown)

FIGURE 10—SOUND TRANSMISSION RATED FLOOR/CEILING ASSEMBLY—SEE [TABLE 7](#) FOR ASSEMBLIES 11—12

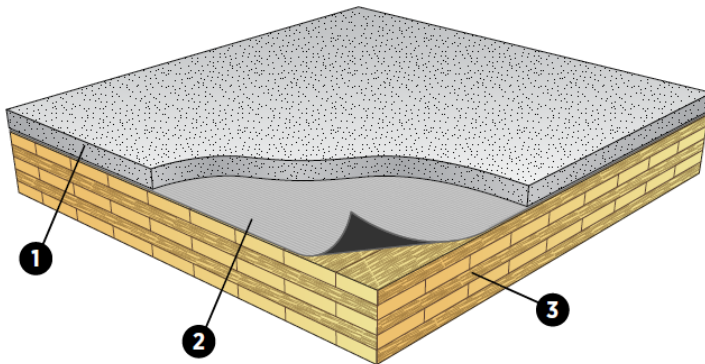

1. Levelrock 2500
2. SAM-N25™ Ultra Sound Mat
3. Cross Laminated Timber
4. Finish System (not shown)

FIGURE 11—SOUND TRANSMISSION RATED FLOOR/CEILING ASSEMBLY—SEE [TABLE 8](#) FOR ASSEMBLY 13

DIVISION: 03 00 00—CONCRETE  
Section: 03 54 00—Cementitious Underlayment

**REPORT HOLDER:**

USG CORPORATION

**EVALUATION SUBJECT:**

USG LEVELROCK BRAND 2500,  
USG LEVELROCK BRAND 2500 FR,  
USG LEVELROCK BRAND 2500 GREEN,  
USG LEVELROCK BRAND 2500 GREEN FR,  
USG LEVELROCK BRAND 2500 LFD  
USG LEVELROCK BRAND 3500,  
USG LEVELROCK BRAND 3500 FR,  
USG LEVELROCK BRAND 3500 GREEN,  
USG LEVELROCK BRAND 3500 GREEN FR,  
USG LEVELROCK BRAND 4500,  
USG LEVELROCK BRAND 4500 FR,  
USG LEVELROCK BRAND CSD EARLY EXPOSURE.

**1.0 REPORT PURPOSE AND SCOPE****Purpose:**

The purpose of this evaluation report supplement is to indicate that USG Levelrock Brand 2500, USG Levelrock Brand 2500 FR, USG Levelrock Brand 2500 Green, USG Levelrock Brand 2500 Green FR, USG Levelrock Brand 2500 LFD, USG Levelrock Brand 3500, USG Levelrock Brand 3500 FR, USG Levelrock Brand 3500 Green, USG Levelrock Brand 3500 Green FR, USG Levelrock Brand 4500, USG Levelrock Brand 4500 FR, USG Levelrock Brand CSD Early Exposure, described in ICC-ES evaluation report [ESR-1846](#), have also been evaluated for compliance with the code(s) noted below.

**Applicable code edition(s):**

- 2022 California Building Code (CBC)

For evaluation of applicable Chapters adopted by the California Office of Statewide Health Planning and Development (OSHPD) AKA: California Department of Health Care Access and Information (HCAI) and the Division of State Architect (DSA), see Sections 2.1.1 and 2.1.2 below.

- 2022 California Residential Code (CRC)

**2.0 CONCLUSIONS****2.1 CBC:**

The USG Levelrock Brand 2500, USG Levelrock Brand 2500 FR, USG Levelrock Brand 2500 Green, USG Levelrock Brand 2500 Green FR, Levelrock Brand 2500 LFD, USG Levelrock Brand 3500, USG Levelrock Brand 3500 FR, USG Levelrock Brand 3500 Green, USG Levelrock Brand 3500 Green FR, USG Levelrock Brand 4500, USG Levelrock Brand 4500 FR, USG Levelrock Brand CSD Early Exposure, described in Sections 2.0 through 7.0 of the evaluation report [ESR-1846](#), comply with CBC Chapters 7 and 12, provided the design and installation are in accordance with the 2021 *International Building Code*® (IBC) provisions noted in the evaluation report and the additional requirements of CBC Chapters 7 and 12, as applicable.

**2.1.1 OSHPD:**

The applicable OSHPD Sections and Chapters of the CBC are beyond the scope of this supplement.

**2.1.2 DSA:**

The applicable DSA Sections and Chapters of the CBC are beyond the scope of this supplement.

**2.2 CRC:**

The USG Levelrock Brand 2500, USG Levelrock Brand 2500 FR, USG Levelrock Brand 2500 Green, USG Levelrock Brand 2500 Green FR, USG Levelrock Brand 2500 LFD, USG Levelrock Brand 3500, USG Levelrock Brand 3500 FR, USG Levelrock Brand 3500 Green, USG Levelrock Brand 3500 Green FR, USG Levelrock Brand 4500, USG Levelrock Brand 4500 FR, USG Levelrock Brand CSD Early Exposure, described in Sections 2.0 through 7.0 of the evaluation report [ESR-1846](#), comply with CRC Chapter R302 and Appendix K, provided the design and installation are in accordance with the 2021 *International Residential Code*® (IRC) provisions noted in the evaluation report and the additional requirements of CRC Chapter R302 and Appendix K, as applicable.

This supplement expires concurrently with the evaluation report, reissued October 2025.