

DETAIL & SUBMITTAL SHEET

by Bilco



SPECIFICATIONS:

Material:

Steel: Cover and frame are 14 ga. G-90 paint bond galvanized steel

Aluminum: Cover and frame are 11 ga. aluminum

Covers: Breakformed, hollow-metal design with 1" concealed fiberglass insulation, 3" beaded, overlapping flange, fully welded at corners, and internally reinforced for 40 psf (195 kg/m²) live load

Curb: 12" in height with integral capflashing, 1" fiberboard insulation, fully welded at corners, and 3-1/2" mounting flange with 7/16" holes provided for securing frame to the roof deck

Gasket: Extruded EPDM rubber gasket permanently adhered to the covers

Hinges: Heavy-duty pintle hinges with 3/8" Type 316 stainless steel hinge pins

Latch: Positive hold/release mechanism controlled by a single UL-listed 165°F (74°C) fusible link with a separate latching point for each cover. Designed to hold the covers closed against a 90 psf (438 kg/m²) wind uplift force. Provided with interior and exterior pull release cables to manually open vent covers.

Performance Ratings: UL-listed and FM-approved. Comply with UL 790 Class A (burning brand test).

Finish:

Steel: Alkyd base red oxide primer

Aluminum: Mill finish

Hardware:

Steel: Engineered composite compression spring tubes. Steel compression springs with electrocoated acrylic finish. All other hardware is zinc plated/chromate sealed.

Aluminum: Engineered composite compression spring tubes. Steel compression springs with electrocoated acrylic finish. Type 316 stainless steel hinges. All other hardware is zinc plated/chromate sealed.

OPTIONS (at additional cost)

- WB Safety Grab
- WB Safety Post
- Railing Ready
- Special sizes available upon request

FRONT ELEVATION

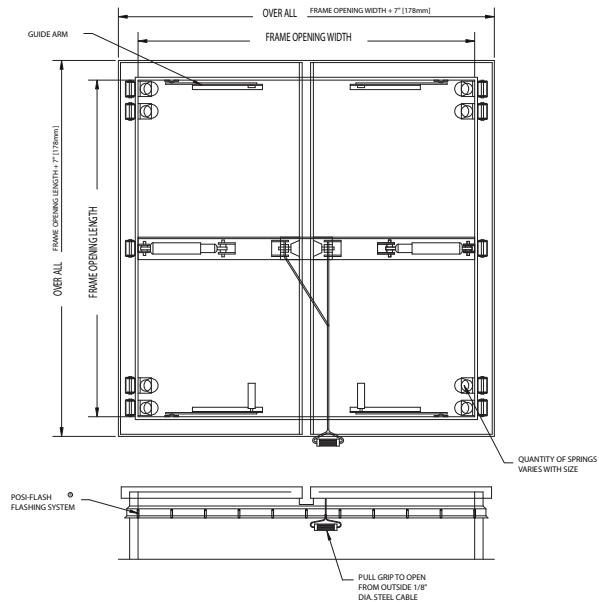

SECTION DETAIL

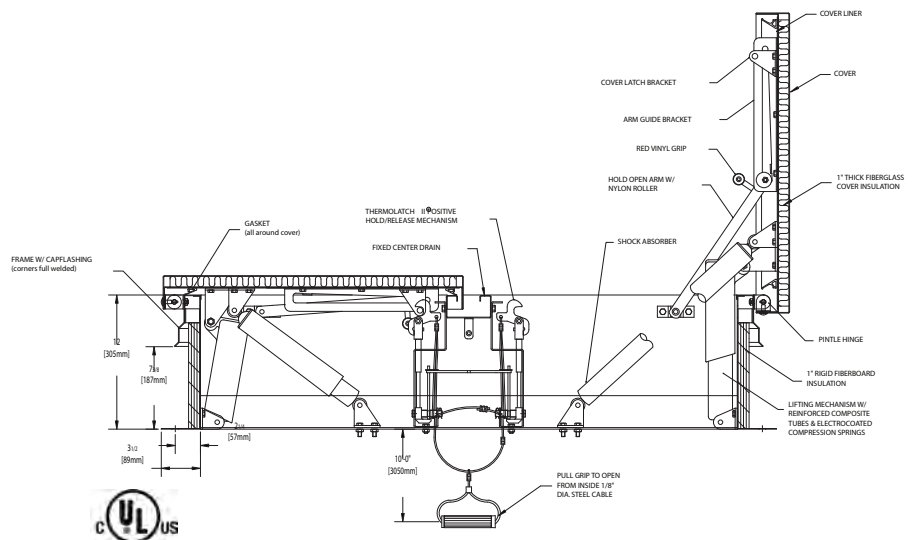

UL-listed. Complies with UL 790 Class A (burning brand test).

✓	Item No.	Door Opening W x H	Material	Ship Wt. Lbs.
	DSH4848	48 x 48	Steel	367
	DSH4872	48 x 72	Steel	455
	DSH4890	48 x 90	Steel	695
	DSH4896	48 x 96	Stl Curb/Al Cvr	485

Project: _____ Date: _____

Contractor: _____ Architect: _____

Sizes: _____ Quantity: _____ Approval Initials: _____



Corporate Office: 1330 Progress Drive • Front Royal, VA 22630
Phone: 1-800-255-5515 • Fax: 1-800-822-5001

www.wbdoors.com