

DETAIL & SUBMITTAL SHEET

by Bilco



SPECIFICATIONS:

Material: Cover and frame are 1/4" steel

Cover: Diamond-pattern tread plate reinforced for 150 psf (732 kg/m²) live load

Frame: Steel angle frame with strap anchors welded around the perimeter

Hinges: Cast steel cam-action hinges that are concealed from the exterior of the door

Latch: Type 316 stainless steel slam lock with fixed interior handle and removable exterior turn/lift handle

Lift Assistance: Torsion bars that pivot on cam-action hinges. Automatic hold-open arm with grip handle release

Finish: Alkyd base red oxide primer

Hardware: Zinc plated/chromate sealed

Item No.	Door Opening W x H	Material	Ship Wt. Lbs.
Q 1	24 x 24	Steel	122
Q 2	30 x 30	Steel	166
Q 3	36 x 30	Steel	190
Q 4	42 x 42	Steel	219

Q-D1 (steel double leaf) available upon request
Q-1AL (aluminum) and Q-DAL (aluminum double leaf) available upon request

FRONT ELEVATION (Double Door)

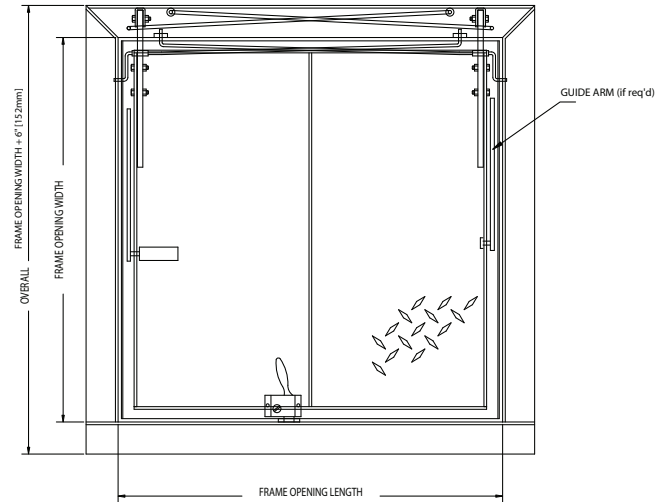

SECTION DETAIL

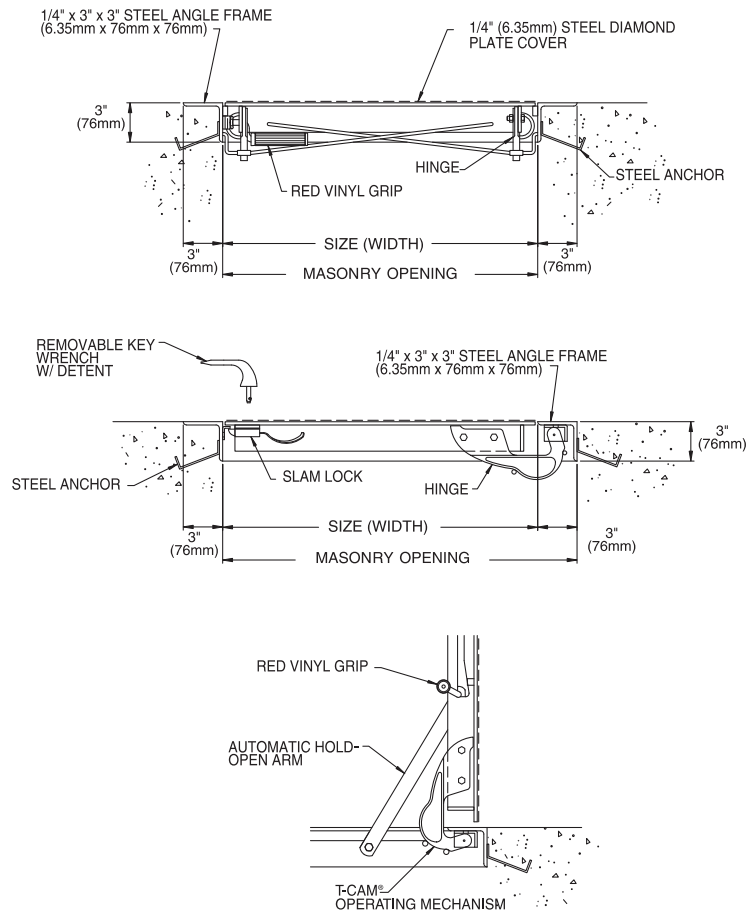

Project: _____ Date: _____

Contractor: _____ Architect: _____

Sizes: _____ Quantity: _____ Approval Initials: _____



Corporate Office: 1330 Progress Drive • Front Royal, VA 22630
 Phone: 1-800-255-5515 • Fax: 1-800-822-5001

www.wbdoors.com