

DETAIL & SUBMITTAL SHEET

by Bilco

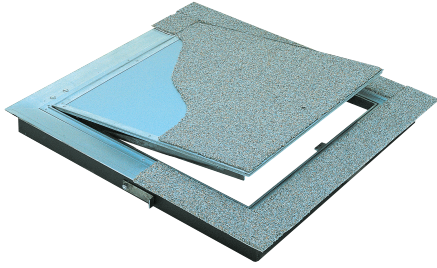

SPECIFICATIONS:

Material: Cover and frame are 1/4" aluminum

Cover: Smooth plate reinforced for 150 psf (732 kg/m²) live load. Extruded aluminum molding fastened to the perimeter to accept floor-covering material [specify either 1/8" (3 mm) or 3/16" (5 mm) molding height]

Frame: Extruded aluminum angle frame with strap anchors bolted around the perimeter. Extruded aluminum molding fastened to the perimeter to accept floor-covering material. [specify either 1/8" or 3/16"]

Hinges: Cast steel cam-action hinges that are concealed from the exterior of the door

Latch: Type 316 stainless steel slam lock with fixed interior handle and removable exterior turn/ lift handle

Lift Assistance: Torsion bars that pivot on cam-action hinges. Automatic hold-open arm with grip handle release

Finish: Mill finish aluminum with a bituminous coating applied to the exterior of the frame

Hardware: Zinc plated/ chromate sealed

✓	Item No.	Door Opening W x H	Material	Ship Wt. Lbs.
	T 1	24 x 24	Aluminum	53
	T 2	30 x 30	Aluminum	68
	T 3	36 x 30	Aluminum	81
	T 4	36 x 36	Aluminum	91

TD available upon request (double leaf)

FRONT ELEVATION (Double Door)

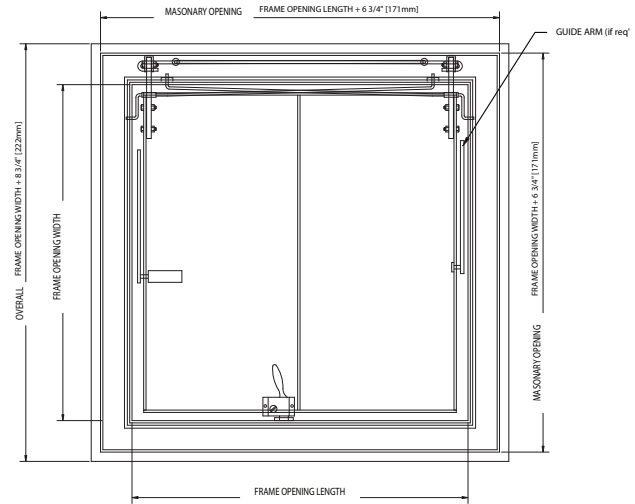

SECTION DETAIL

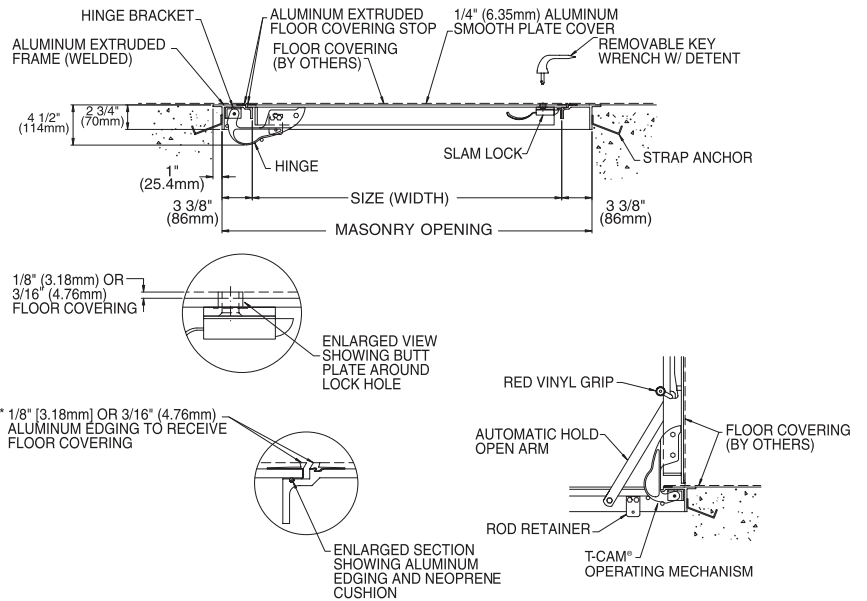

Project: _____ Date: _____

Contractor: _____ Architect: _____

Sizes: _____ Quantity: _____ Approval Initials: _____



Corporate Office: 1330 Progress Drive • Front Royal, VA 22630
Phone: 1-800-255-5515 • Fax: 1-800-822-5001

www.wbdoors.com

* Stock item