

# PRODUCT SUBMITTAL

## #2752 Column Anchor

**WIRE-BOND**

For anchoring masonry to structural columns when masonry is perpendicular to the column flange while restraining both positive and negative wind load actions.

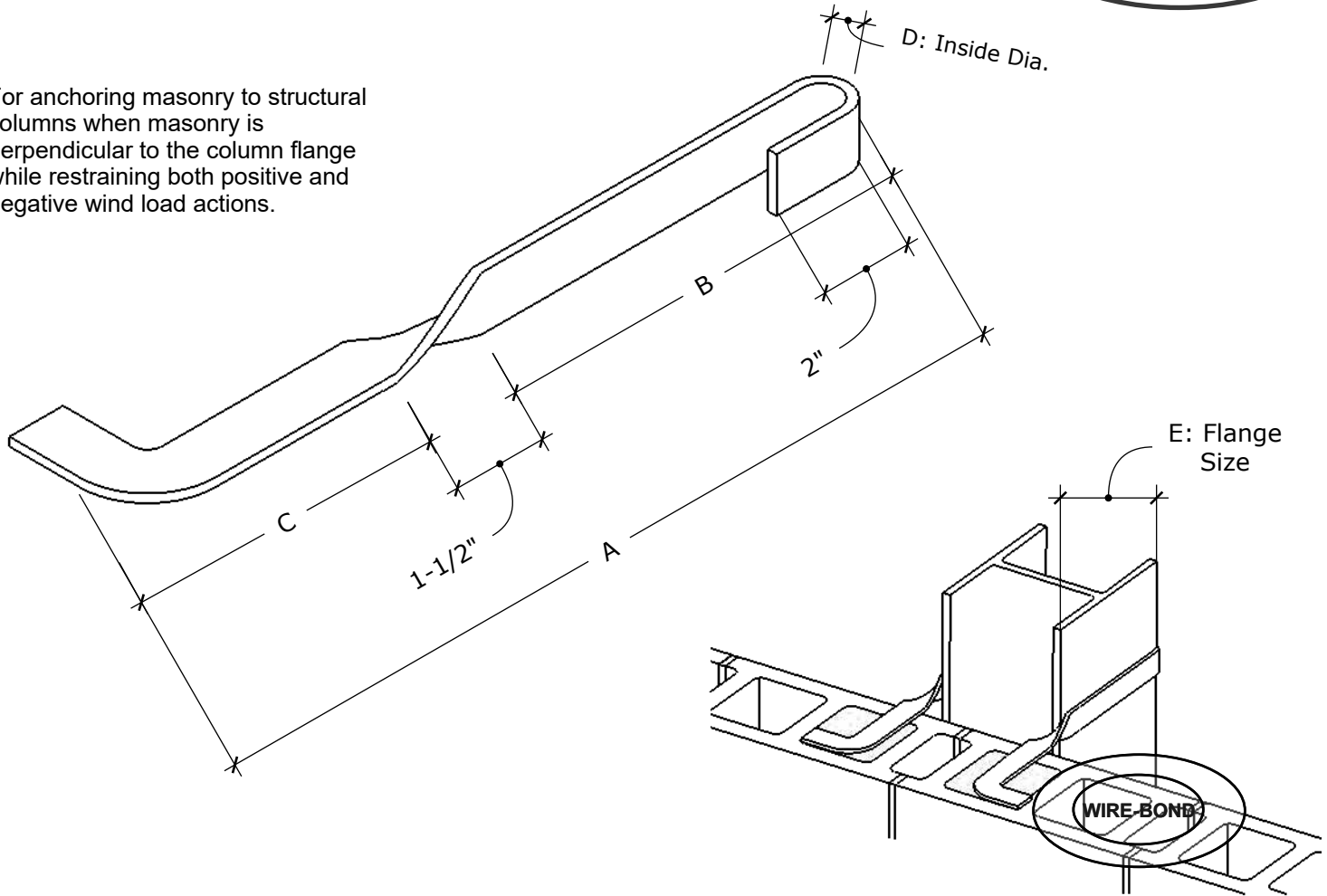

**SHEET METAL** - (Carbon Steel): ASTM A1008 / A1008M or ASTM A36/A36M

**Hot Dip Galvanized after fabrication / Zinc Coating**  
ASTM A153 / A153M-B2 (1.50 oz per sq ft) or ASTM A123/A123M

**SHEET METAL** - (Stainless Steel): ASTM A666, ASTM A480/480M, and ASTM A240/A240M. AISI Type 304 or 316

**SHEET METAL** - 3/4" wide x 1/4" thick x specified length.  
Made to order based on dimensions listed to the right.



**Recycled Content:**  
Hot Dipped,  
82.8% Post-Consumer  
17% Post Industrial / Pre-Consumer,  
  
Stainless Steel,  
60% Post Consumer  
V O C Content - 0%

**ANCHOR THICKNESS:**

1/4"

**ANCHOR DIMENSIONS** (refer to drawing above):

- A. Overall Length \_\_\_\_\_
- B. Length Before Twist \_\_\_\_\_
- C. Length Past End of Twist \_\_\_\_\_
- D. Inside Diameter of Hook \_\_\_\_\_
- E. Flange Size \_\_\_\_\_

**FINISH:**

Hot Dip Galvanized

Stainless Steel: Type 304

Stainless Steel: Type 316

**Corporate Office:** 400 Rountree Rd Charlotte, NC 28217  
TEL: (800) 849-6722 FAX: (704) 525-3761

**Mailing Address:** P.O. Box 240988 Charlotte, NC 28224



wirebond.com

**Memphis Plant:** 2365 Harbor Ave. Memphis, TN 38113  
TEL: (800) 441-8359 FAX: (901) 775-94

**Mailing Address:** P.O. Box 13124 Memphis, TN 38113