

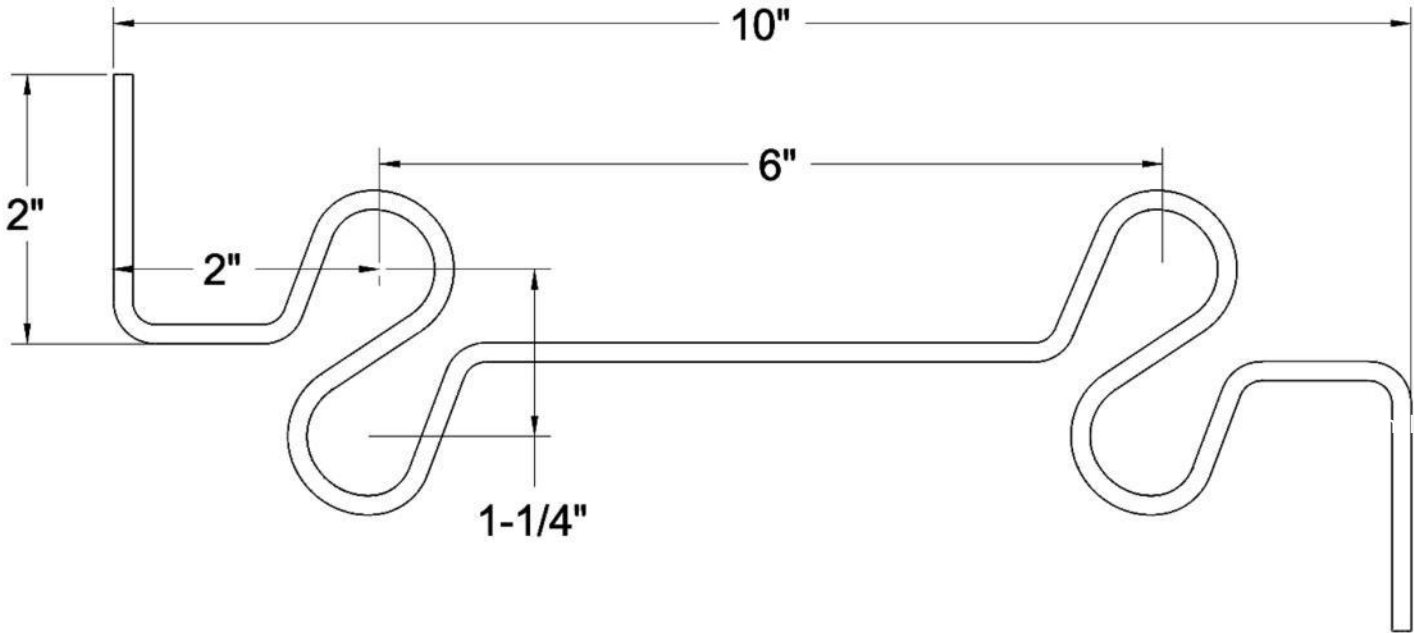

PRODUCT SUBMITTAL



3404 Figure 8 Double Rebar Positioner For 12 inch CMU



Loops hold up to 1" diameter Rebar

MATERIAL CONFORMANCE	SIZES / FINISHES
<p>Wire (Carbon Steel): Prefabricated from cold-drawn steel wire conforming to ASTM A1064/A1064M, ASTM A82 / A82M Tensile Strength - 80,000 psi Yield Point - 70,000 psi</p> <p>Mill Galvanized / Zinc Coating: ASTM A641 / A641M (0.10 Oz per sq ft)</p> <p>Hot Dip Galvanized after fabrication / Zinc Coating ASTM A153 / A153M-B2 (1.50 oz per sq ft)</p> <p>Stainless Steel (WIRE) ASTM A580 / ASTM A580M Stainless Steel (SHEET METAL) ASTM A167 Type 304 (Type 316 available on special order)</p>  <p>Recycled Content: Mill Galvanized & Hot Dipped, 82.8% Post-Consumer 17% Post Industrial / Pre-Consumer,</p> <p>Stainless Steel, 60% Post Consumer V O C Content - 0%</p>	<p># 3404 :</p> <p>9 gauge dia. 10 inch for 12 inch CMU</p> <p>FINISH:</p> <p><input type="checkbox"/> Mill Galvanized <input type="checkbox"/> Hot Dip Galvanized <input type="checkbox"/> Stainless Steel</p>

Corporate Office: 400 Rountree Rd Charlotte, NC 28217
TEL: (800) 849-6722 FAX: (704) 525-3761

Mailing Address: P.O. Box 240988 Charlotte, NC 28224



www.wirebond.com

Memphis Plant: 2365 Harbor Ave. Memphis, TN 38113
TEL: (800) 441-8359 FAX: (901) 775-9449

Mailing Address: P.O. Box 13124 Memphis, TN 38113