

PRODUCT SUBMITTAL

Mesh Wall Tie #1900 and #1901

For bonding Intersecting Masonry walls

WIRE-BOND

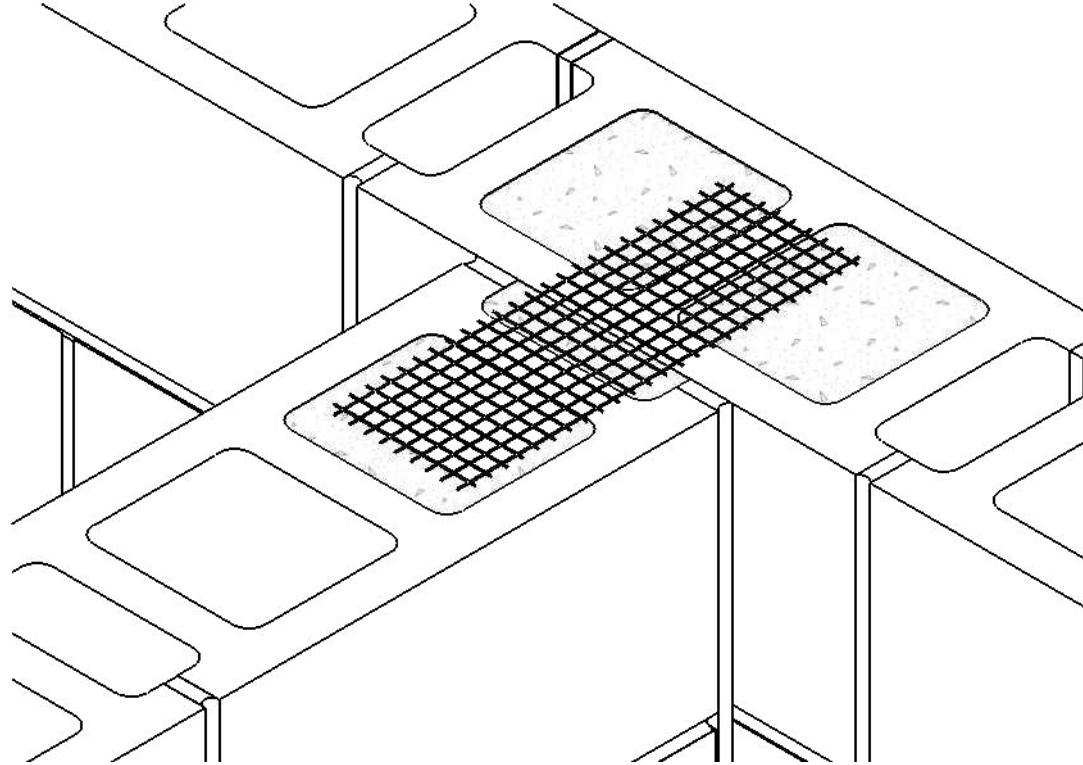
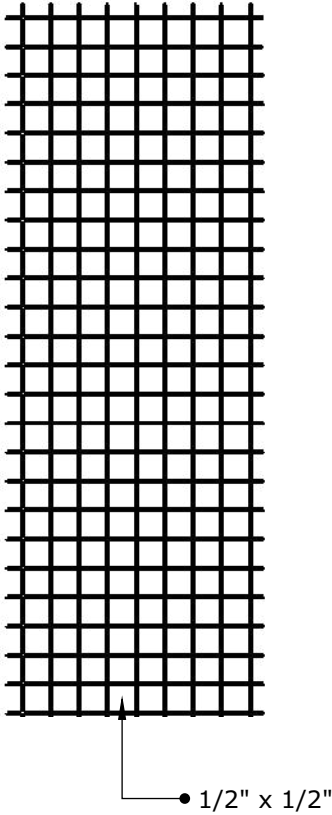

Mesh Wall Tie #1900 and #1901

MATERIAL CONFORMANCE:

ASTM A185
ASTM A82 / A82M - (Cold drawn steel wire)
ASTM A740 - (Hardware Cloth)

ASTM A951 Standard Specification for Steel Wire for
Masonry Joint Reinforcement

Hot Dip Galvanized after fabrication / Zinc Coating

ASTM A153 / A153M-B2 (1.50 oz per sq ft) or ASTM A123/A123M

Stainless Steel ASTM E2016, Type 304

Recycled Content:

Hot Dipped,
82.8% Post-Consumer
17% Post Industrial / Pre-Consumer,

Stainless Steel,
60% Post Consumer
V O C Content - 0%



GAUGES:

#1900 16 gauge

#1901 19 gauge

LENGTH:

8"

12"

100' roll (standard)

Other _____

WIDTH (for roll or piece):

3" (for 4" wall)

4" (for 6" wall)

6" (for 8" wall)

8" (for 10" wall)

10" (for 12" wall)

Other _____

FINISH:

Hot Dip Galvanized

Stainless Steel

Corporate Office: 400 Rountree Rd Charlotte, NC 28217
TEL: (800) 849-6722 FAX: (704) 525-3761

Mailing Address: P.O. Box 240988 Charlotte, NC 28224



wirebond.com

Memphis Plant: 2365 Harbor Ave. Memphis, TN 38113
TEL: (800) 441-8359 FAX: (901) 775-94

Mailing Address: P.O. Box 13124 Memphis, TN 38113