

# PRODUCT SUBMITTAL

**WIRE-BOND**

## # 2401 RJ-711 Seismic (Metal Clip)

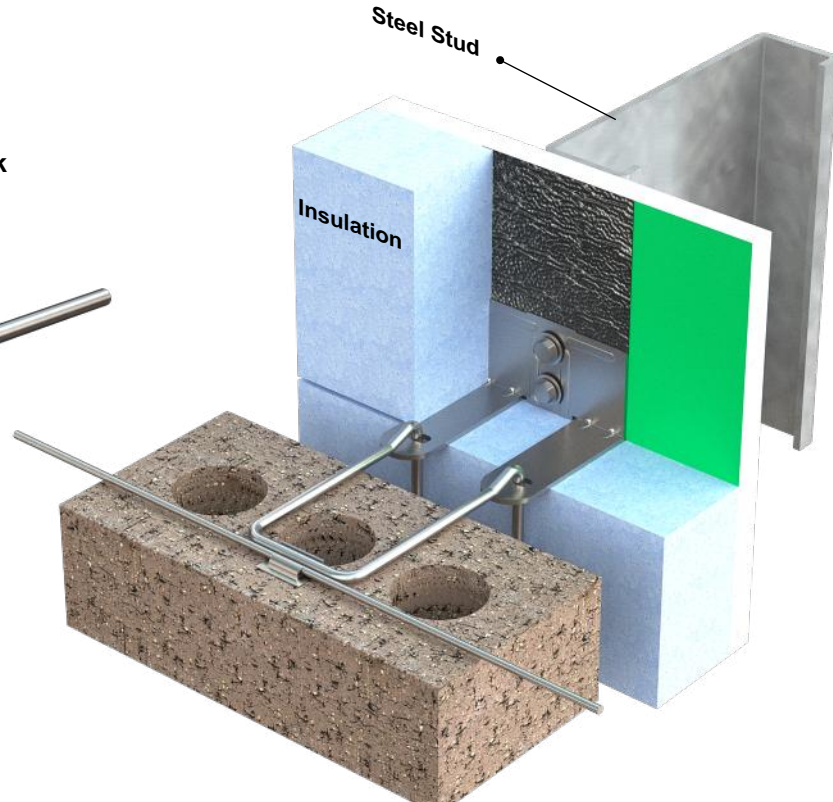
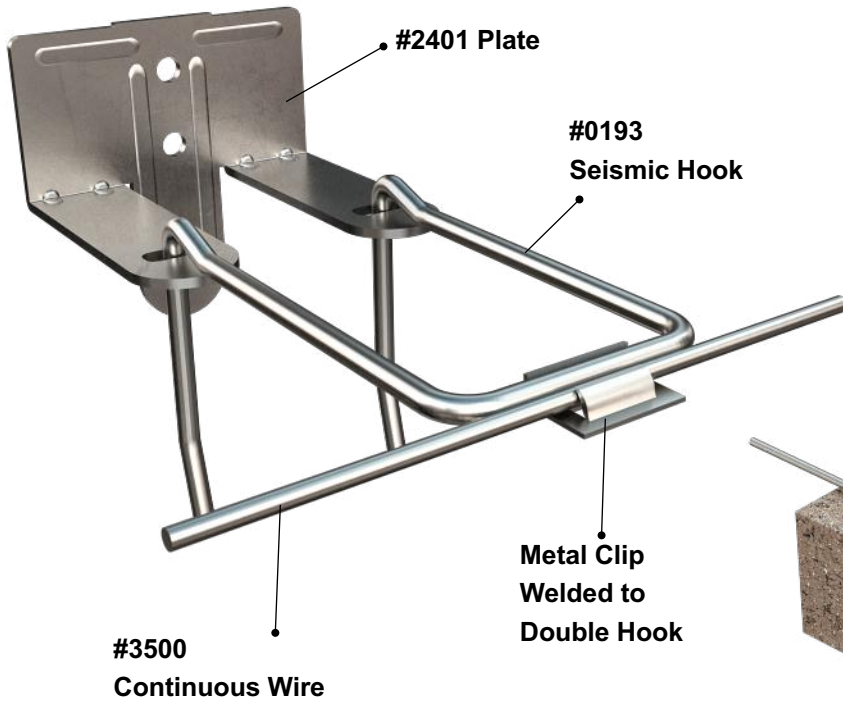

### MATERIAL CONFORMANCE

**ASTM A1064/A1064M** - (Cold drawn steel wire)  
Tensile Strength - 80,000 psi  
Yield Point - 70,000 psi

**ACI / ASCE 530** - (Building code requirements for masonry structures)

**SHEET METAL** - (Carbon Steel) **ASTM A1008 / A1008M**  
Mill Galvanized / Zinc Coating: **ASTM A641 / A641M (0.10 Oz per sq ft)**  
Hot Dip Galvanized after fabrication / Zinc Coating  
**ASTM A153 / A153M-B2 (1.50 oz per sq ft)**

Stainless Steel **ASTM 580 / ASTM 580M Type 304** (Type 316 available on special order)

**Recycled Content:**  
Mill Galvanized & Hot Dipped,  
82.8% Post-Consumer  
17% Post Industrial / Pre-Consumer,

Stainless Steel,  
60% Post Consumer  
V O C Content - 0%



### SIZES / FINISHES

**# 2401 RJ711:**  
14 gauge      12 gauge  
Must be 3/4" more than insulation

**Insulation:**

0"	1"	1-1/2"	2"	2-1/2"
3"	3-1/2"	4"		

**#0193 Seismic Hook:** 3/16" Diameter Standard  
3-1/4"    4-1/4"    5-1/4"    Other \_\_\_\_\_



**Continuous Wire:**  
9gauge      3/16" dia.



**FINISH:**  
Mill Galvanized      Hot Dip Galvanized      Stainless Steel

**Corporate Office:** 400 Rountree Rd Charlotte, NC 28217  
TEL: (800) 849-6722 FAX: (704) 525-3761

**Mailing Address:** P.O. Box 240988 Charlotte, NC 28224

**WIRE-BOND**

[www.wirebond.com](http://www.wirebond.com)

**Memphis Plant:** 2365 Harbor Ave. Memphis, TN 38113  
TEL: (800) 441-8359 FAX: (901) 775-9449

**Mailing Address:** P.O. Box 13124 Memphis, TN 38113