

STONE ANCHORS

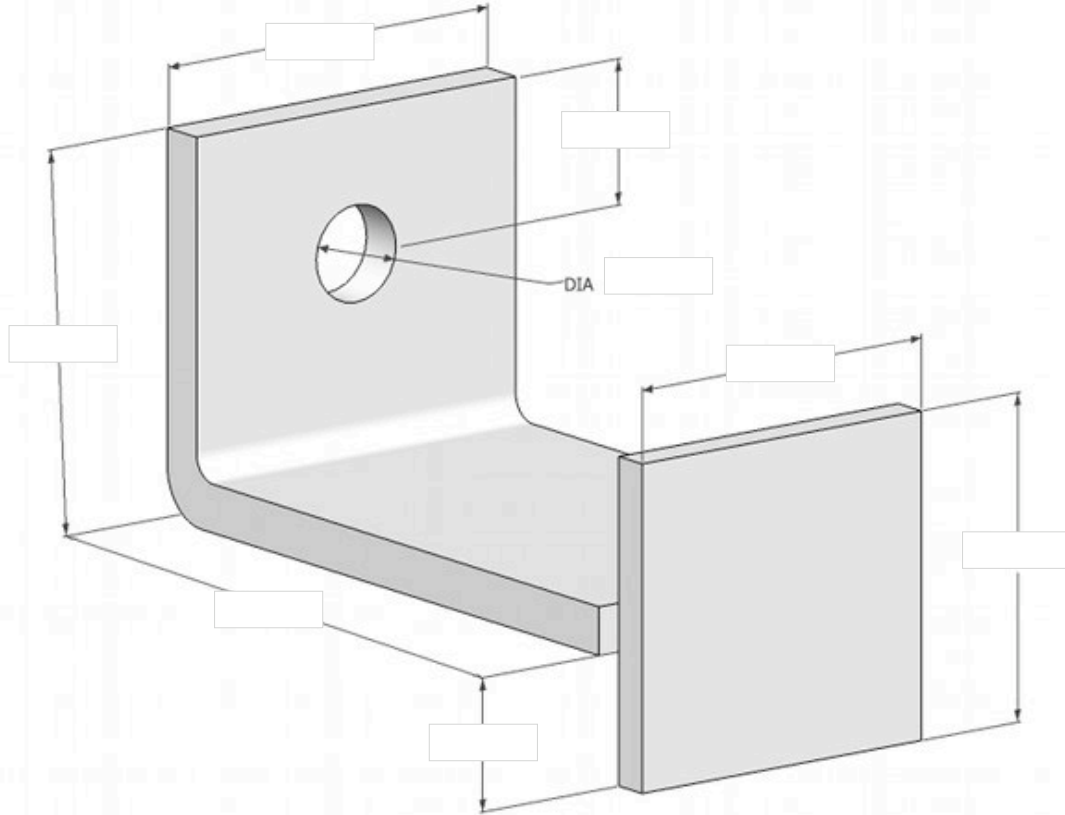

#3054 "L" Anchor with welded tab



QUANTITY: _____

ST/ST Min. Fy = 45,000 p.s.i (ASTM A666)

THICKNESS:

- 1/8" 1/4"
 3/16" Other _____

FINISH:

- Hot Dip Galv.
 Stainless Steel Type 304

Welded Tab Thickness:

- 1/8" 1/4"
 3/16" Other _____

CONTACT INFORMATION:

Name: _____
 Company: _____
 Phone: _____ Fax: _____
 E-mail: _____

PROJECT INFORMATION:

Name: _____
 Location: _____

