

PRODUCT SUBMITTAL

WIRE-BOND

#3056 "U" Anchor

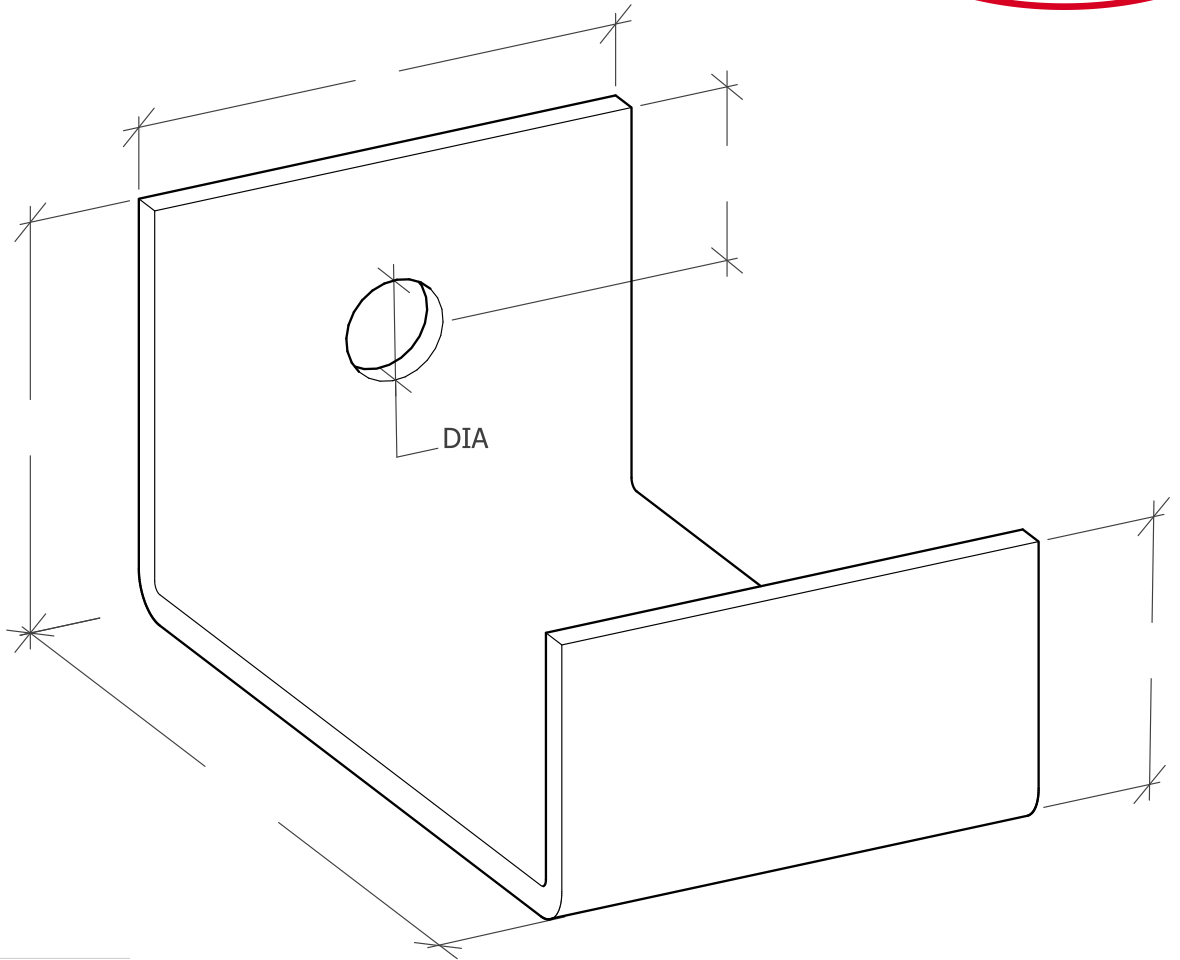

QUANTITY: _____

THICKNESS:

1/8"

1/4"

3/16"

Other _____

FINISH:

Hot Dip Galv.

Stainless Steel Type 304

ST/ST Min. Fy = 45,000 p.s.i (ASTM A666)

Stainless Steel Type 316

CONTACT INFORMATION:

Name: _____

Company: _____

Phone: _____ Fax: _____

E-mail: _____

PROJECT INFORMATION:

Name: _____

Location: _____

Corporate Office: 400 Rountree Rd Charlotte, NC 28217
TEL: (800) 849-6722 FAX: (704) 525-3761

Mailing Address: P.O. Box 240988 Charlotte, NC 28224



www.wirebond.com

Memphis Plant: 2365 Harbor Ave. Memphis, TN 38113
TEL: (800) 441-8359 FAX: (901) 775-9449

Mailing Address: P.O. Box 13124 Memphis, TN 38113