

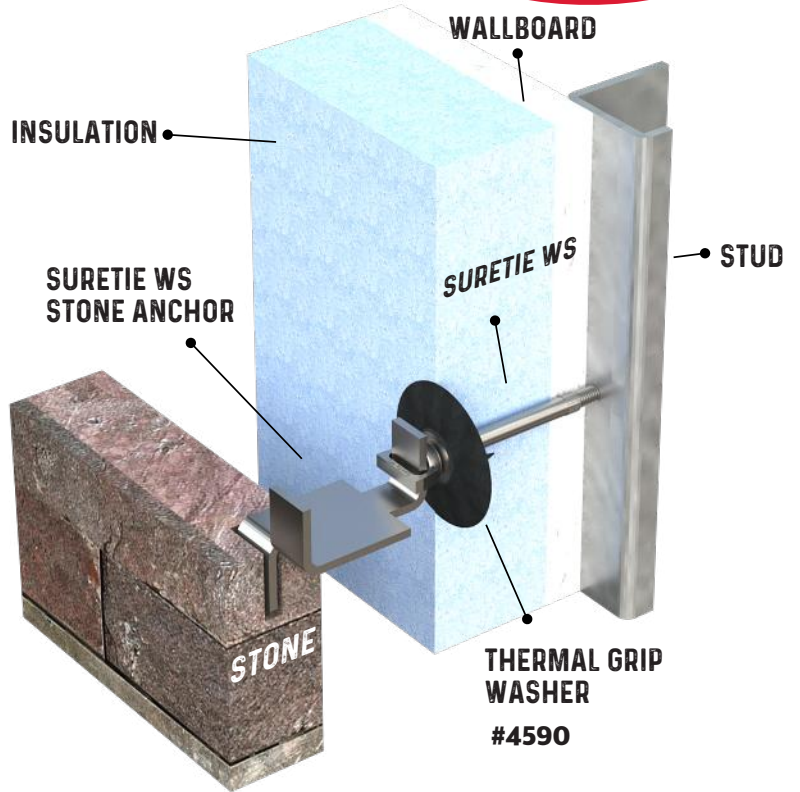

PRODUCT SUBMITTAL

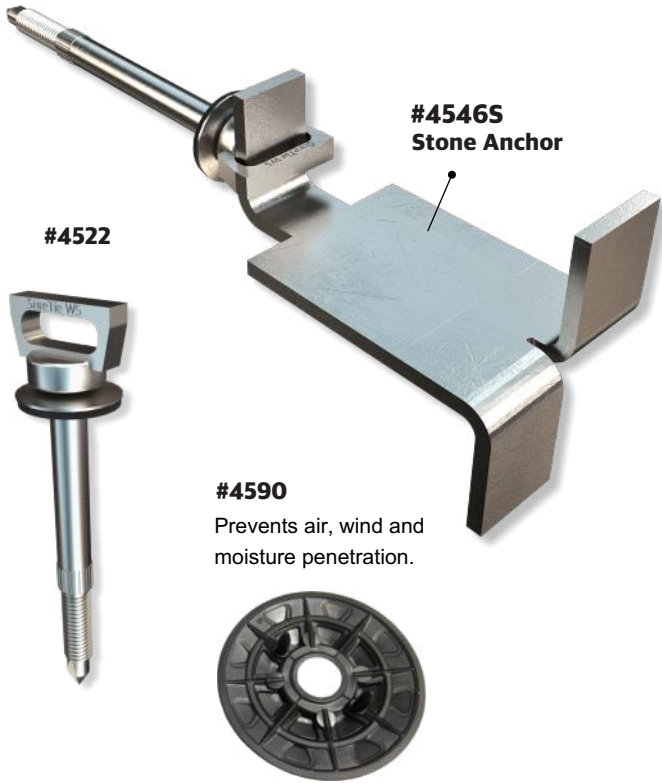

SureTie WS Stone Anchor



MATERIAL CONFORMANCE	SIZES / FINISHES
<p>SHEET METAL - (Carbon Steel) ASTM A1008 / A1008M ACI / ASCE 530 - (Building code requirements for masonry structures)</p> <p>Hot Dip Galvanized after fabrication / Zinc Coating ASTM A153 / A153M-B2 (1.50 oz per sq ft)</p> <p>Sheet Metal (Stainless Steel): ASTM A666, ASTM A480/480M, and ASTM A240/A240M - AISI Type 304 or Type 316</p> <p>Recycled Content: Mill Galvanized & Hot Dipped, 82.8% Post-Consumer 17% Post Industrial / Pre-Consumer,</p> <p>Stainless Steel, 60% Post Consumer V O C Content - 0%</p> 	<p># 4522 SureTie WS Silver-gray climaseal finish resulted in 0% red rust at 1000 hours exposure to ASTM B-117 salt spray testing.</p> <p>Insulation: 0" 1" 1-1/2" 2" 2-1/2" 3" 3-1/2" 4" 4-1/2"</p> <p>#4546S SureTie WS Stone Anchor: 1-1/4" wide</p> <p>Thickness: 1/8" 3/16"</p> <p>Length:</p> <p>Split:</p> <p>FINISH : (#4540 Stone Anchor) Hot Dip Galvanized Stainless Steel</p> <p>ST/ST Min. Fy = 45,000 p.s.i (ASTM A666)</p> <p>#4590 Thermal Grip Washer 2" dia. washer with solid cap design (no keyholes) Pre-spotting prongs Stiffened center "Bullseye" ring prevents fastener pull-through Flexible perimeter compresses on surface and reduces tearing Flattens on surface of insulation</p>

Corporate Office: 400 Rountree Rd Charlotte, NC 28217
 TEL: (800) 849-6722 FAX: (704) 525-3761

Mailing Address: P.O. Box 240988 Charlotte, NC 28224



www.wirebond.com

Memphis Plant: 2365 Harbor Ave. Memphis, TN 38113
 TEL: (800) 441-8359 FAX: (901) 775-9449

Mailing Address: P.O. Box 13124 Memphis, TN 38113