



# INSTALLATION GUIDELINES MEL-DRAIN™

## ACCESSORIES:

W. R. MEADOWS offers several accessory products to help with the proper installation of MEL-DRAIN. PERMINATOR TAPE is recommended for the sealing, seaming, terminating and connecting details referenced in this document. Any tape designed for underground use is acceptable provided it offers a strong bond that will not deteriorate over time in typical or anticipated subsurface conditions.

## ATTACHMENT METHODS:

Common attachment methods for drainage products include TERMINATION BAR with mechanical fasteners, construction adhesives, double-sided tapes, insulation anchors, and nails through washers or wood lathing. Construction adhesives with high solvent contents should be avoided as they may damage MEL-DRAIN. Acceptable attachment methods are dependent upon substrate. POINTING MASTIC or MEL-PRIME™ can be used as an adhesive for installation of MEL-DRAIN. Please consult W. R. MEADOWS Technical Services for additional information.

**CONCRETE OR WOOD:** Construction adhesives, double-sided tape, or mechanical fasteners.

**SOIL:** 4-inch to 8-inch long galvanized nails on approximately 4-foot spacing. Nail length will vary depending upon the surface to which MEL-DRAIN is being attached. Nails should have flat heads, and washers or wood lathing may be used to prevent the nail head from being driven through the prefabricated drain.

**WATERPROOFING MEMBRANES:** Construction adhesives, double-sided tape, or insulation anchors are suitable attachment methods. Check with W. R. MEADOWS for compatibility before using construction adhesives in conjunction with W. R. MEADOWS waterproofing materials. When using anchors, make sure waterproofing material is not penetrated or damaged in any way.

## DRAINAGE CONNECTION FLANGE:

MEL-DRAIN is manufactured with a core flange on each roll. The flange is a flat section of plastic that extends beyond the molded dimples on one side. The flange is designed to connect rolls to each other to facilitate water flow and transportation. Rolls are designed with integrated fabric flaps that extend beyond the flange edge to secure seams and terminate edges, preventing soil intrusion into the water flow channel.

Rolls can be installed vertically (in columns) or horizontally (in rows) against the installation surface. All rolls should be installed with flanges oriented in a consistent manner.

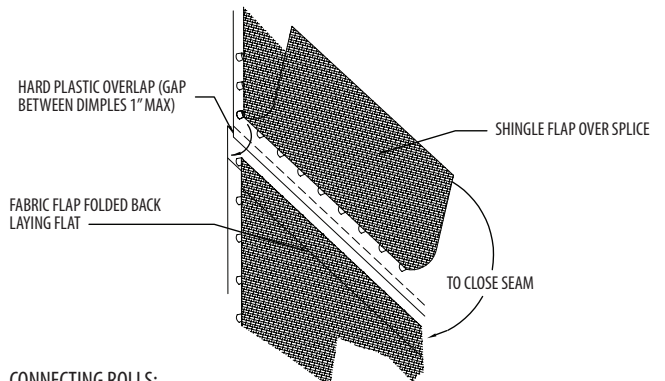
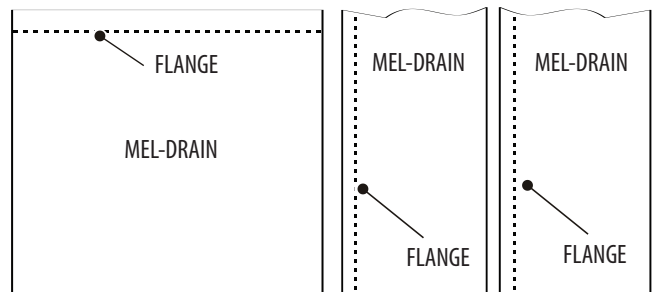

## CONNECTING ROLLS:

1. Attach the first roll of sheet drain to the wall using recommended attachment method.
2. Attach additional rolls by placing the flush edge of the roll over the connection flange on the adjacent roll.
3. Use fabric flaps to secure seams.
4. Seal all edges of drain prior to backfill.



**W. R. MEADOWS, INC.** | P.O. Box 338 | HAMPSHIRE, IL 60140-0338  
 Phone: 847/214-2100 | Fax: 847/683-4544 | [www.wrmeadows.com](http://www.wrmeadows.com)



# INSTALLATION GUIDELINES MEL-DRAIN

When installed horizontally (rows), the core flange should be at the upstream edge. Additional rolls should be oriented in a consistent manner with the non-flanged edge installed over the flange edge of the previously installed roll. Integrated fabric flaps are used to cover the seams prior to backfill. Fabric flaps should be seamed in a downstream direction when possible.

PERMINATOR TAPE or spray adhesives can be used to secure fabric flaps at seams.

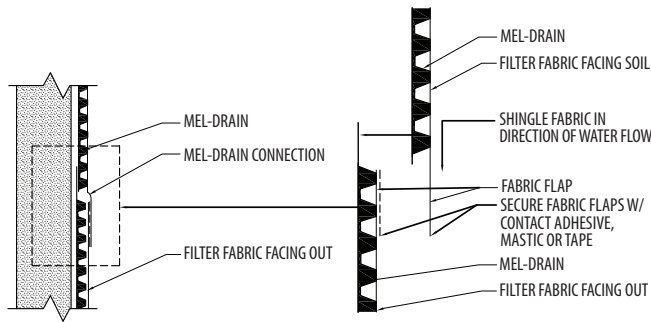

### SEALING EDGE TERMINATIONS & PENETRATIONS:

MEL-DRAIN products are installed in subsurface applications and care should be taken when backfilling to ensure soil is not able to enter the prefabricated drainage core through roll seams or edges.

#### SEAMS AND EDGES:

Fabric flaps are provided on MEL-DRAIN to facilitate seam and edge terminations.

- MEL-DRAIN has fabric flaps on the long edges of each roll.
- MEL-DRAIN products provide fabric flaps on the top/flange open edge to facilitate the connection of additional rolls.

For additional security, spray adhesive or PERMINATOR TAPE can be used to secure fabric flaps in place prior to backfill.

#### NOTE:

The ends of all rolls/products without fabric flaps must be secured with tape or fabric prior to backfill.

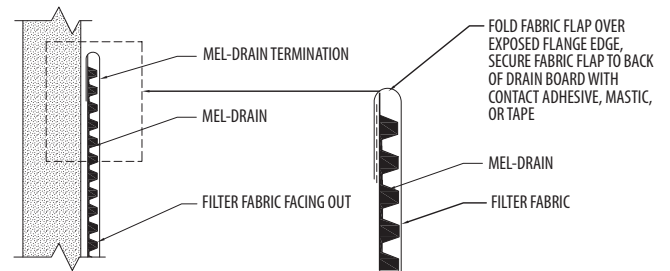

TERMINATION - Flange Edge - Vertical

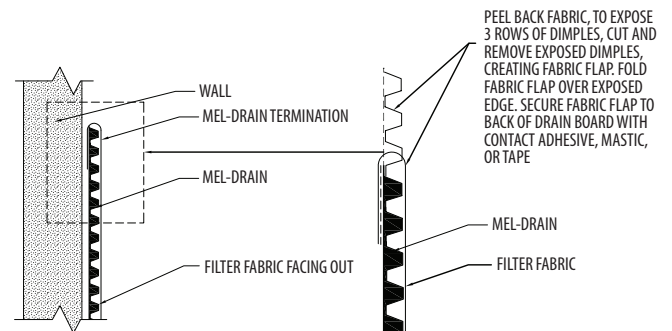

TERMINATION - Non-Flange Edge - Vertical

#### PENETRATIONS:

Penetrations (such as pipes) through MEL-DRAIN should be sealed using PERMINATOR TAPE to insure backfill material is not able to enter the drainage core.

#### FABRIC CUTS:

Cuts in the fabric less than 2" (25.4 mm) wide should be sealed using PERMINATOR TAPE. Cuts in the fabric larger than 2" (25.4 mm) wide require a patch of filter fabric (of the same type used on the drainage





# INSTALLATION GUIDELINES MEL-DRAIN

product) extending a minimum 3" (76.2 mm) in all directions beyond the damaged fabric be used to cover the cut. The patch should be secured in place over the cut using PERMINATOR TAPE or spray adhesive.

### BACKFILLING:

Soil should be placed and compacted directly against MEL-DRAIN at the compaction requirement specified by the designer. Direct compactor exhaust away from MEL-DRAIN to prevent damage. Backfill to a minimum of 3" (76.2 mm) above MEL-DRAIN to allow for coverage after settlement.

### VERTICAL APPLICATIONS

When using MEL-DRAIN sheet drains in vertical applications, the area of installation should be clear of debris. Limit foot traffic and/or heavy equipment directly on MEL-DRAIN during horizontal installations to avoid damage to the drainage channel.

### BACKFILLED WALL:

Install MEL-DRAIN with fabric side toward soil.

### SHORING WALL (BLINDSIDE WALL):

Install MEL-DRAIN with fabric side toward shoring. Concrete or gunite/shotcrete may be placed against the core side of the drain.

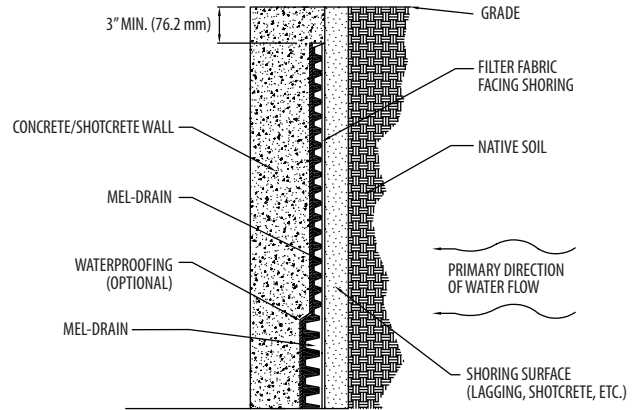

The geotextile filter fabrics used in MEL-DRAIN are designed specifically for use in subsurface drainage applications and are designed to allow backfilling directly against the fabric side. MEL-DRAIN is offered with various geotextile filter fabrics to meet specific application requirements. For example, standard-weight non-woven fabrics are commonly used in vertical wall applications with soil/aggregate backfill, medium-weight non-woven fabrics for applications such as angular rock backfill, and heavyweight woven or non-woven fabrics for horizontal and/or concrete pour applications. Physical and performance properties for the fabrics are listed on the MEL-DRAIN data sheet, and include strength properties, such as grab tensile strength and CBR puncture strength, so designers can specify heavier-grade (stronger) fabrics if desired based on their specific application requirements.

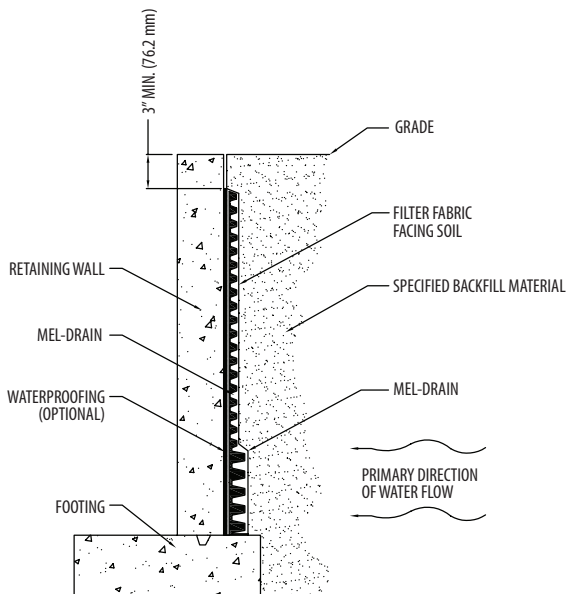

**W. R. MEADOWS, INC.** | P.O. Box 338 | HAMPSHIRE, IL 60140-0338  
 Phone: 847/214-2100 | Fax: 847/683-4544 | [www.wrmeadows.com](http://www.wrmeadows.com)